

Generation IV Roadmap
Description of Candidate
Gas-cooled Reactor Systems Report

**Issued by the Nuclear Energy Research Advisory Committee
and the Generation IV International Forum**

December 2002



MEMBERS OF THE GAS-COOLED REACTOR SYSTEMS TECHNICAL WORKING GROUP

Franck Carré	Co-chair	Atomic Energy Commission – France, France
Philip Hildebrandt	Co-chair	Engineering, Management, and Technology, Inc., United States
Finis Southworth	Technical Director	Idaho National Engineering and Environmental Laboratory, United States
Timothy Abram		British Nuclear Fuels Limited, United Kingdom
Sydney Ball		Oak Ridge National Laboratory, United States
Bernard Ballot		Framatone – Advanced Nuclear Programs, France
Arden Bement		Purdue University, United States
Phillip Finck		Argonne National Laboratory, United States
Kosaku Fukuda		International Atomic Energy Agency, United Nations
Dominique Greneche		COGEMA, France
Andrew C. Kadak		Massachusetts Institute of Technology, United States
Shin Whan Kim		Korea Power Engineering Company, Korea
Masuro Ogawa		Japanese Atomic Energy Research Institute, Japan
Arkal Shenoy		General Atomics, United States
Werner von Lensa		Forschungszentrum Juelich, European Commission

OTHER CONTRIBUTORS

James Kendall		International Atomic Energy Agency, United Nations
Hussein Khalil	RIT Representative	Argonne National Laboratory, United States
William Naughton	GRNS Representative	Exelon, United States
Jacques Royen	Gas TWG Secretariat	Nuclear Energy Agency, OECD
John M. Ryskamp	RIT Representative	Idaho National Engineering and Environmental Laboratory, United States
Bob Seidel		Argonne National Laboratory West, United States
Steven Sorrell	DOE Representative	Department of Energy Idaho Operations Office, United States

Contents

MEMBERS OF THE GAS-COOLED REACTOR SYSTEMS TECHNICAL WORKING GROUP	2
EXECUTIVE SUMMARY	5
ACRONYMS.....	7
1. INTRODUCTION.....	9
2. CONCEPT SETS.....	10
2.1 Pebble Bed Reactor Systems.....	10
2.2 Prismatic Fuel Modular Reactor Systems.....	11
2.3 Very-High-Temperature Reactor Systems.....	11
2.4 Gas-Cooled Fast Reactor Systems.....	12
2.5 Other Concepts.....	12
2.6 Gas-Cooled Reactor Fuel Cycle Flexibility.....	13
2.7 Technical Uncertainties Requiring Research and Development.....	13
3. CONCEPT SETS EVALUATION.....	15
3.1 Pebble Bed Reactor Systems.....	15
3.2 Prismatic Fuel Modular Reactor Systems.....	16
3.3 Very-High-Temperature Reactor Systems.....	16
3.4 Gas-Cooled Fast Reactor Systems.....	16
4. CONCLUSIONS AND RECOMMENDATIONS.....	17
5. REFERENCES.....	19
APPENDIX A—Modular Pebble Bed Reactor Systems.....	21
APPENDIX B—Prismatic Fuel Modular Reactor Systems.....	57
APPENDIX C—Very-High-Temperature Reactor Systems.....	83
APPENDIX D—Gas-Cooled Fast Reactor Systems.....	121
APPENDIX E—Gas-Cooled Reactor Systems.....	147
APPENDIX F—Table of Requests for Information, Responses, and Technical Working Group Concepts	159
APPENDIX G—Modular Helium Reactor for Nonelectric Applications of Nuclear Energy.....	163

DISCLAIMER

This information was prepared as an account of work by the Generation IV International Forum (GIF). Neither the GIF, nor any of its members, nor any GIF member's national government agency or employee thereof, makes any warranty, express or implied, or assumes any legal liability or responsibility for the accuracy, completeness, or usefulness of any information, apparatus, product, or process disclosed, or represents that its use would not infringe on privately owned rights. References herein to any specific commercial product, process, or service by trade name, trademark, manufacturer, or otherwise, does not necessarily constitute or imply its endorsement, recommendation, or favoring by the GIF, its members, or any agency of a GIF member's national government. The views and opinions of authors expressed herein do not necessarily state or reflect those of the GIF, its members, or any agency of a GIF member's national government.

EXECUTIVE SUMMARY

This report provides a description and evaluation of candidate gas-cooled reactor (GCR) systems in support of the Generation IV Technology Roadmap. The GCR systems described and evaluated herein are based on the twenty-one summary concept descriptions provided (1) in public response to the U.S. Department of Energy request for information and (2) by members of the Gas-Cooled Technical Working Group (Gas-TWG). The latter descriptions were prepared to complement the public response to ensure the broadest range of candidate systems were considered based on the collective knowledge of the Gas-TWG members, and include review of selected reports prepared by other agencies worldwide.

The membership of the Gas-TWG is broadly experienced in the design, construction, and operation of reactors, in particular, GCRs. The membership is drawn from several countries and international organizations, and provides an international perspective and opinion of the potential for GCR systems to fulfill the goals for sustainability, safety and reliability, and economics for a Generation IV nuclear energy system.

The concepts considered are grouped into the following four concept sets, representing the common capabilities and attributes among the concepts:

- Modular Pebble Bed Reactor Systems
- Prismatic Fuel Modular Reactor Systems
- Very-High-Temperature Reactor Systems
- Gas-Cooled Fast Reactor Systems.

The concept sets provide the ability to evaluate the aggregate characteristics of the concepts in the set and to identify the common technical needs for subsequent consideration as potential research and development (R&D) activities in the Generation IV Technology Roadmap. Each concept set is described in a separate Appendix to this report, uses a reference reactor system for detailed description and evaluation, and describes important variations suggested by the submitted concepts.

The four concept sets constitute a comprehensive family of nuclear energy systems that envelope a wide range of applications (e.g., electrical power generation, process heat, thermo-chemical hydrogen production, sea water desalination) with strong synergies in R&D needed for their commercial deployment.

The pebble bed technology and the prismatic fuel technology that are the bases for two of the concept sets lead to industrial projects that are concluded to satisfactorily meet Generation IV goals and are judged to be deployable about 2010 to 2015. The two other concept sets illustrate the potential of gas-cooled systems for enhanced performance, both towards higher temperatures to achieve very high conversion efficiencies and enhance hydrogen production, and towards use of a fast neutron spectrum for enhanced sustainability.

The results of the screening-for-potential evaluations may be summarized as follows:

- Each of the four concept sets offers reactor systems with the potential to fulfill the goals for a Generation IV nuclear energy system.
- A technical basis exists to conclude that many of the GCR systems would not incur fuel damage under accident conditions and could be certified to meet protective action guidelines at the site

boundary. As a consequence, a high-pressure, conventional-type containment is considered unnecessary, and the size of emergency planning zone (EPZ) could be greatly reduced compared to the reference advanced light water reactors (ALWRs), with the EPZ anticipated to extend only to the site boundary.

- This is achieved using refractory-coated fuel particles (e.g., using silicon carbide coatings) and a limited size core at low power density. The particle fuel consists of a spherical kernel of fissile or fertile fuel material encapsulated in multiple coating layers. The multiple coating layers form a miniature, highly corrosion resistant pressure vessel and an essentially impermeable barrier to release of gaseous and metallic fission products.
- The GCR systems provide thermodynamic conditions that support a broad spectrum of potential applications, ranging from electrical power generation to alternate fuel production (e.g., hydrogen) that make substantial in-roads in reducing production of carbon gases released to the atmosphere. These systems achieve high thermodynamic efficiencies and have application potential well beyond the reference ALWRs.
- For example, the pebble bed and prismatic fuel concept sets achieve outlet temperatures of about 850°C leading to thermal efficiencies approaching 48% for a direct Brayton cycle gas turbine. At these temperatures, hydrogen production is practical via steam reforming or IS processes. In the case of the very-high-temperature reactor system concept sets, temperatures above 900°C and potentially approaching 1200°C may be achieved, with thermal efficiencies approaching 60%. Additional potential high-temperature applications, such as coal gasification and glass manufacture, are also possible, in addition to efficient production of hydrogen.
- The operating characteristics of the GCR systems accommodate use of a wide range of fuel cycles without changing the basic system design. The applicable fuel cycles range from low-enriched uranium to thorium-uranium, to plutonium alone. Prismatic block GCRs can also utilize the discharged and separated transuranic (TRU) waste from other reactors. The high burnup capability of the TRISO fuel particle allows for the fission of over 90% of the fissile plutonium in the TRU in a single irradiation cycle. Effectively, the prismatic block reactor can destroy a significant part of its own waste.
- The thermal and epithermal GCR concepts provide the capability to achieve much higher burnups compared to the reference ALWRs, with the attendant capability to burn most of the minor actinides, thereby reducing the waste heat load and radio-toxicity.
- To achieve even greater sustainability improvements beyond the thermal GCR, a fast neutron spectrum GCR system can be used. This reactor system concept has a closed fuel cycle using high conversion or breeding of fissile materials. A breeding capability around unity may be of interest if a synergistic fuel cycle with light water reactors is desired. The fast neutron spectrum reactor system provides a breeding capability that affords burning of about 70% of the energy of the natural uranium compared to only a few percent for thermal systems. The fast neutron spectrum reactor can use depleted uranium as the make-up fuel, thus precluding further mining of natural uranium.
- The R&D needs for GCR systems range from investigation of selected technical uncertainties (e.g., fuel microsphere containment integrity for more mature reactor systems) to fundamental R&D (e.g., for fuel design and materials for Very-High-Temperature reactor system and fast neutron spectrum reactor system applications).

ACRONYMS

ALWR	Advanced Light Water Reactor
DBA	design basis accident
EPZ	Emergency Planning Zone
GCR	gas-cooled reactor
GFR	Gas-Cooled Fast Reactor
HEU	high-enriched uranium
HTTR	High Temperature Engineering Test Reactor
IHX	intermediate heat exchanger (HTTR)
LEU	low-enriched uranium
LWR	light water reactor
MEDUL	multiple-recirculating feeding system
MHD	magnet-hydrodynamic
MOX	mixed oxide (fuel)
NEA	Nuclear Energy Agency (of OECD)
OTTO	once-through-then-out
PBR	<u>P</u> ebble <u>B</u> ed <u>R</u> eactor
peu-a-peu	little by little
PMR	<u>P</u> rismatic Fuel <u>M</u> odular <u>R</u> eactor
PNP	<u>P</u> rototype <u>N</u> uclear <u>P</u> rocess Heat
PWR	pressurized water reactor
REMHD	Radiation Enhanced Magneto-Hydrodynamic
TRISO	refractory (coated particle fuel)
TRU	transuranic
TWG	Technical Working Group
VHTR	Very-High-Temperature Reactor

Description of Candidate Gas-cooled Reactor Systems Report

TWG-2 Summary Report

1. INTRODUCTION

The Gas-Cooled Reactor Systems Technical Working Group (Gas-TWG) was formed in January 2001 as one of four technical working groups supporting the Generation IV Technology Roadmap [Bennett, et al. 2001]. The goal of the Generation IV initiative is to identify and develop next generation nuclear energy systems that are deployable by 2030 and can meet energy needs through the 21st century. These nuclear energy systems will be developed to meet stringent performance goals [Levy, et al. 2001] in sustainability (e.g., resource utilization, waste minimization, environmental impact, and proliferation resistance), safety and reliability, and economics.

The Gas-TWG, during preparation of this report, had eleven members from the United States and ten members representing England, France, Japan, Korea, the European Commission, the International Atomic Energy Agency, and the Nuclear Energy Agency (NEA) of the Organization for Economic Cooperation and Development. The NEA provides the secretariat function for the Team. Team members are drawn from universities, national laboratories, government agencies, and industry, and are broadly experienced in the design, construction, and operation of reactors, in particular, gas-cooled reactors (GCRs). This membership provides an international perspective and opinion of the potential for GCR systems to fulfill the goals for sustainability, safety and reliability, and economics for a Generation IV nuclear energy system.

Twenty-one high-temperature, GCR system concepts were contributed to the Gas-TWG, forming the starting concepts for developing a research and development (R&D) roadmap. Most of these concepts, for purposes of identifying technical uncertainties or innovations to support Generation IV performance goals, were aggregated into the four nuclear energy system concept sets described in Section 2.

Gas-cooled reactor systems have several fundamental characteristic features that distinguish them from other types of reactors and provide significant operational advantages. In particular, the fuel is in the form of small ceramic-coated particles capable of Very-High-Temperature operation, the moderator is solid graphite, and the coolant is neutronically inert helium or carbon dioxide.

One of the benefits of such a fuel arrangement is that GCR systems are able to accommodate a wide variety of fissile and fertile material mixtures without any significant modification of the core design. This flexibility is due to an uncoupling between the parameters of cooling geometry and the parameters that characterize neutronic optimization (i.e., moderation ratio or heavy nuclide concentration and distribution). It is possible to modify the packing fraction of coated particles in the fuel within the graphite matrix without changing the dimensions of the fuel elements (number and diameter of cooling holes for prismatic block cores or pebble diameter for pebble bed cores). Other physical reasons favour the adaptability of GCR systems regarding the fuel cycle in comparison with reactors using moderators in the liquid form, such as light water reactors (LWRs). A good illustration, is the void coefficient, which limits the plutonium content of pressurized water reactor (PWR) mixed oxide (MOX) fuels¹ and which is

¹ If a total loss of water occurs in a PWR, the neutron spectrum becomes very fast due to the reduced moderation. In these conditions, neutron multiplication by plutonium isotopes increases significantly because of better neutron reproduction of plutonium isotopes in the fast range.

not a constraint for GCR systems. A GCR core has less parasitic capture in the moderator (capture cross section of graphite is 100 times less than the one of water) and internal structures.

Finally, GCR systems fuels are able to reach very high burnups, which are far beyond the possibilities offered by other thermal reactors (except the particular case of molten salt reactors). This capability allows for essentially complete plutonium fission in a single burnup and minimizes the proliferation risk in the use of this fuel form.

2. CONCEPT SETS

The GCR systems described and evaluated herein are based on the twenty-one summary concept descriptions provided (1) in public response to the U.S. Department of Energy request for information and (2) by members of the Gas-TWG. The latter descriptions were prepared to complement the public response to ensure the broadest range of candidate systems was considered based on the collective knowledge of the Gas-TWG members, and include review of selected reports prepared by other agencies worldwide.

Nineteen of the twenty-one concepts considered are grouped into the following four concept sets, representing the common capabilities and attributes among the concepts:

- Modular Pebble Bed Reactor Systems (PBRs)
- Prismatic Fuel Modular Reactor Systems (PMRs)
- Very-High-Temperature Reactor Systems (VHTRs)
- Gas-Cooled Fast Reactor Systems (GFRs).

The concept sets provide the ability to evaluate the aggregate characteristics of the concepts in the set and to identify the common technical needs for subsequent consideration as potential R&D activities in the Generation IV Technology Roadmap. Each concept set is described in a separate Appendix to this report, uses a reference reactor system for detailed description and evaluation, and describes important variations suggested by the submitted concepts.

2.1 Pebble Bed Reactor Systems

Key design characteristics of both PBRs and PMRs (see Section 2.2) are the use of helium coolant, graphite moderator, and refractory (TRISO)-coated particle fuel. The helium coolant is inert and remains single phase under all conditions; the graphite moderator has high strength and stability to high temperatures; and the TRISO-coated particle fuel retains fission products to high temperatures. The TRISO-coated particle fuel consists of a spherical kernel of fissile or fertile material, as appropriate for the application, encapsulated in multiple coating layers. The multiple coating layers form a miniature, highly corrosion-resistant pressure vessel and an essentially impermeable barrier to the release of gaseous and metallic fission products.

In the PBR concepts, the TRISO-coated microspheres are contained in a 6 cm ball configuration as the fuel form (i.e., the “pebble”). In the inner 5 cm, the coated particles are homogeneously distributed within a pyrocarbon matrix surrounded by a 0.5 cm outer pyrocarbon shell, with the carbon particle coatings, matrix, and shell acting as moderator. There are two generic concepts for PBRs in terms of refueling. The most common is the online, multiple-recirculating feeding system (MEDUL) in which pebbles are continuously removed, controlled with regard to their burn-up and mechanical integrity, then transported back to the top of the reactor core if they did not yet reach the burn-up target. Fresh fuel is

only added as needed to maintain criticality over the full range of operating conditions. The other types are the once-through-then-out (OTTO) concept where the pebbles only perform one passage through the core, and the *peu-a-peu* (little-by-little) scheme in which fuel is added to maintain criticality then completely discharged and replaced when the vessel is full. For the on-line refueling designs, the pebbles are circulated by gravity in the core, which is surrounded by a graphite reflector, and pneumatically transported in the fuel handling system. Normally, the graphite reflector is not easily exchangeable and has to resist high neutron fluences and thermal effects that accumulate during lifetime, although future designs contemplate replacement if required.

The PBR concepts use a thermal neutron spectrum and have the capability to maintain fuel integrity under all design basis accidents (DBAs) with no reliance on active safety systems for short-term safety functions. Long-term shutdown systems are required for anticipated transients without scram events. Analyses have shown that the core cannot melt down. The refractory core, low power density, and low excess reactivity enable this design approach. PBRs also exhibit high efficiency, with either a direct or indirect gas turbine power conversion system, with or without a bottoming cycle using the relatively high exit temperature (about 500°C) helium from the turbine. The reference PBR is 250 MWth and 115 MWe. Other variations use intermediate heat exchangers (IHXs) to facilitate process heat applications or steam cycle power conversion while maintaining moisture isolation from the primary coolant circuit. Online refueling of the PBRs leads to low excess reactivity in the core while allowing very high reactor availability.

2.2 Prismatic Fuel Modular Reactor Systems

Prismatic Fuel Modular Reactor systems have the same key design characteristics as PBRs and use the same TRISO-coated particles except that they are shaped into different configurations. For the prismatic designs, TRISO-coated particles are mixed with a matrix and formed into cylindrical fuel compacts approximately 13 mm in diameter and 51 mm long. The fuel compacts are loaded into fuel channels in hexagonal graphite fuel elements measuring 793 mm long by 360 mm across flats. One hundred and two columns of the hexagonal fuel elements are stacked 10 elements high to form an annular core. Reflector graphite blocks are provided inside and outside of the active core.

The PMR system uses a thermal neutron spectrum and is designed to maintain fuel integrity under all DBAs with minimal active safety system requirements. Batch refueling requires periodic refueling shutdowns, but the fuel cycle flexibility is appreciable. High-burnup, low-enriched uranium (LEU, more than 5%) once-through fuel cycles are the reference approach. The high thermal efficiency of the systems leads to better than current generation fuel utilization. The reference PMR power level is 600 MWth and 286 MWe. Combinations of LEU, high-enriched uranium (HEU), plutonium recycle, thorium-uranium, and excess weapons material burning are fuel cycle flexibilities exhibited by the PMRs. PMRs can also utilize the discharged and separated transuranic (TRU) waste from thermal reactors, and efficiently utilize the fissionable material, primarily plutonium, in this waste. The reference PMR concept has core exit coolant temperatures of about 850°C.

2.3 Very-High-Temperature Reactor Systems

Very-High-Temperature Reactors are those concepts that have average coolant outlet temperatures above 900°C or operational fuel temperatures above 1250°C. These concepts provide the potential for increased energy conversion efficiency and for high-temperature process heat applications, such as coal gasification or thermochemical hydrogen production. While all the GCR concepts considered have sufficiently high temperature to support process heat applications, such as desalination or cogenerative processes, as well as some thermochemical processes of interest to alternative fuel production, the VHTRs higher temperatures open a broader and more efficient range.

These concepts require substantive improvements in the fuel design, especially in material properties. High temperature alloys, fiber reinforced ceramics or compound materials, and ZrC coatings of the fuel are promising candidates. The benefit of these developments is not restricted to dedicated VHTR applications but is valid for all kinds of high temperature reactor applications irrespective of the core design. Thus, the VHTR concepts and applications can be taken primarily as an important direction for innovative, future long-term R&D.

The reference concept has a block type core and is based on the Gas Turbine – Modular Helium Reactor (GT-MHR) connected to a steam reformer/steam generator unit in the primary circuit. It is an advanced, high-efficiency reactor system that can be used in energy-intensive, non-electric processes, as well as supply process heat to a broad spectrum of high temperature applications. It can also be equipped with an IHX, as is the case in the High Temperature Engineering Test Reactor (HTTR), to broaden the application spectrum. PBR concepts are also applicable options for VHTRs.

2.4 Gas-Cooled Fast Reactor Systems

Gas-Cooled Fast Reactor concepts offer a closed fuel cycle through high conversion or breeding of fissile materials. A breeding capability around unity may be of interest if the GFR is used in a synergistic fuel cycle with LWRs. GFRs using a direct Brayton cycle have the potential to combine the advantages of high sustainability and economic competitiveness while making nuclear energy benefit from the most efficient conversion technology available.

The reference concept is a 600 MW_{th}/288 MWe, helium cooled reactor system operating with an outlet temperature of about 850°C and using a direct Brayton cycle gas turbine. The thermal efficiency is estimated to approach 48%. There are several fuel design options including both the prismatic (with fuel particles or composite fuels) and fuel pins (with actinide compound/solid solution). A major challenge is to develop adequate fuel technologies and associated core design and treatment processes to preserve most of the attractive safety features of thermal GCRs.

2.5 Other Concepts

Two unique concepts were submitted. The first was the "Conceptual Design of a Fluidized Bed Nuclear Reactor," submitted by H. van Dam, et al, of Delft University. This concept utilizes a fluidized bed (helium coolant with fluidized TRISO fuel particles) of strongly under-moderated LEU fuel wherein the fuel fluidization elevates the fuel into a reactor region containing sufficient moderating reflector material (graphite) to maintain criticality. The concept description has a novel approach to a small power reactor (16 MW_{th}). However, given the insufficient system description, this concept was not considered as a Generation IV reactor power system for the purposes of the roadmap. As such, this report will not assess the concept further.

The second concept was "Advanced Nuclear Power System Using Cesium Based Radiation Enhanced Magneto-Hydrodynamic (REMHD) Cycles," submitted by Prof. A. Kadak of the Massachusetts Institute of Technology. This system is designed to combine the extremely high possible efficiencies of a magneto-hydrodynamic (MHD) "turbine," the high power densities associated with liquid metal Rankine cycles, and the ability to operate such a system with reasonable heat addition and rejection temperatures. REMHD systems seek to increase the efficiency of MHD systems by enabling the MHD turbine to expand the gas to even lower temperatures while maintaining sufficient ionization to maintain the conductivity above the critical point. The concept marries very high-temperature, GCR systems with the REMHD. Because the concept is principally a unique advanced power conversion system applicable to VHTR reactor systems discussed in Section 2.3 above, the concept is not carried forward. The VHTR future technical innovations may draw upon this concept in later roadmap stages.

2.6 Gas-Cooled Reactor Fuel Cycle Flexibility

High-temperature, GCR systems have several fundamental characteristics that distinguish them from and provide significant operational advantages over other types of reactors. In particular, the fuel is in the form of small, ceramic-coated particles capable of very high coolant temperature operation, the moderator is solid graphite, and the coolant is neutronically inert (e.g., helium or carbon dioxide). Note also that while the coated particle fuel structure is capable of withstanding elevated temperatures, the average and maximum operating fuel temperatures of GCRs are typically considerably lower than for LWRs.

One of the benefits of such a fuel arrangement is that the GCRs accommodate a wide variety of mixtures of fissile and fertile materials without any significant modification of the core design. This flexibility is due to uncoupled cooling geometry and neutronic optimization (i.e., moderation ratio or heavy nuclide concentration and distribution). The solid moderator in GCRs also avoids the void coefficient, which limits the plutonium content of LWR MOX fuels.

High-temperature GCR fuels are able to reach very high burn-ups, which are far beyond the possibilities offered by other thermal reactors (except the particular case of molten salt reactors). This capability allows for essentially complete plutonium fission in a single burnup and minimizes the proliferation risk in the use of this fuel form. Hence, the operating characteristics of the GCRs accommodate use of a wide range of fuel cycles without changing the basic reactor system design. The applicable fuel cycles range from LEU to thorium-uranium to plutonium alone. Appendix E provides a detailed summary of the flexibility inherent with the GCR concepts regarding fuel cycles.

2.7 Technical Uncertainties Requiring Research and Development

As can be seen from the above descriptions, enhanced GCRs are based on a common set of basic technologies that include:

- Coated fuel particles (TRISO or BISO) that assure an effective confinement of fission products up to 1600°C
- High-temperature helium or carbon dioxide systems technology
- High-temperature materials for the core, in vessel structures (e.g., advanced ferritic and martensitic steels), primary systems and associated components (e.g., advanced ferritic steels).

The PBR and PMR technologies that are the bases for two of the concept sets lead to industrial projects that are concluded to satisfactorily meet Generation IV goals and are judged to be deployable around 2010 to 2015. The two other concept sets illustrate the potential of GCR systems for enhanced performance, both towards higher temperatures to achieve very high conversion efficiencies and enhance hydrogen production, and towards use of a fast neutron spectrum for enhanced sustainability. This enhanced sustainability can be achieved through efficient and flexible use of available fissile and fertile nuclear fuels, efficient burning of long-lived radioactive waste, and enhanced intrinsic and extrinsic proliferation resistance.

These various classes of GCR systems rely on strongly synergetic research work:

- Improvement of the TRISO fuel particles (e.g., coatings, geometry, materials), including higher temperature capability (e.g., zirconium carbide vs. silicon carbide for VHTR applications) and acceptable fuel forms for fast neutron spectrum applications. These improvements can be

retrofitted in the PBR and PMR concept sets to provide additional margins for safety or economic considerations.

- High-temperature capability steels for both reactor plant and power conversion applications
- High-temperature systems technology
- Analytical code development
- Instrumentation for high-temperature applications.

3. CONCEPT SETS EVALUATION

Overall, each of the four GCR concept sets provides reactor systems with the potential to fulfill the goals for a Generation IV nuclear energy system. These goals may be summarized as follows:

Sustainability – Generation IV nuclear energy systems will:

- Include fuel cycles, provide sustainable energy generation that meets clean air objects and promotes long-term availability of systems and effective fuel utilization for worldwide energy production
- Minimize and manage their nuclear waste and notably reduce the long term stewardship burden in the future, thereby improving protection for the public health and the environment
- Increase the assurance that they are very unattractive and least desirable for diversion or theft of weapons-usable materials.

Safety and Reliability – Generation IV nuclear energy systems will:

- Excel in safety and reliability
- Have a very low likelihood and degree of reactor core damage
- Eliminate the need for offsite emergency response.

Economics – Generation IV nuclear energy systems will:

- Have life-cycle cost advantage over other energy sources
- Have a level of financial risk comparable to other energy projects.

The reference concept for each of the four concept sets was evaluated and scored using the screening-for-potential criteria provided by the Evaluation Methodology Group. This methodology included several “sub-goals” for each of the above goals with suggested criteria and metrics for evaluation compared to the reference Advanced Light Water Reactor (ALWR) system.

Where particularly important, the potential variation due to the individual concepts is described. Generally, the Gas-TWG found the scoring approach and criteria to be of limited utility at a level of detail below the “goal” level. Although the scoring sheets were completed as requested by the Evaluation Methodology Group, the more detailed criteria are most useful in providing suggested considerations that should be weighed in judging the relative merit at the goal level and are described accordingly in the Appendices. The following summarizes selected strengths and uncertainties associated with each of the concept sets.

3.1 Pebble Bed Reactor Systems

The PBR system concept set scored “better” to “much better” than the reference ALWR. Of particular note are (1) improved safety due to the inherent design capability to preclude damage to the fuel under all operating and accident conditions within the design basis; (2) reduced total cycle costs; (3) intrinsic proliferation resistance of the fuel form (several hundred thousand pebbles would have to be diverted to obtain sufficient plutonium); and (4) reduced waste disposal burden based on improved overall efficiency, higher burnup, lower specific heat load, and the potential that the spent fuel form is expected

to be suitable for direct disposal in the repository without an overpack. Important uncertainties common to PBR systems include:

- Confirming fuel performance (integrity) under accident conditions
- Validation of physics and thermodynamic modeling
- Effects of air and water ingress
- High-temperature material behavior, including selected materials qualification such as for the reactor vessel and core graphite
- Performance testing for selected design features of the direct cycle turbine generator.

3.2 Prismatic Fuel Modular Reactor Systems

As with the PBR systems concept, the PMR system concept set scored “better” to “much better” than the reference ALWR. Of particular note are (1) improved safety due to the inherent design capability to preclude damage to the fuel under all operating and accident conditions within the design basis; (2) reduced total cycle costs; (3) intrinsic proliferation resistance of the fuel form due to the refractory coated fuel form and low fissile fuel volume fraction; and (4) reduced waste disposal burden based on improved overall efficiency, higher burnup, lower specific heat load, and the potential that the spent fuel form is expected to be suitable for direct disposal in the repository without an overpack. Important uncertainties common to the PMR system include:

- Confirming fuel performance (integrity) under accident conditions
- Validation of physics and thermodynamic modeling
- Effects of air and water ingress
- High-temperature material behavior, including selected materials qualification such as for the reactor vessel and core graphite
- Performance testing for selected design features of the direct-cycle turbine generator.

3.3 Very-High-Temperature Reactor Systems

The VHTR systems scored “better” to “much better” compared to the referenced ALWR. Of particular note are (1) the high thermal efficiency; (2) reduced generation of highly active and long-lived radiotoxic nuclides; (3) larger scope of potential waste applications, for example, coal gasification and metallurgic processes; and (4) improved proliferation resistance due to low fissile inventories. Important uncertainties, in addition to those identified for PBRs and PMRs, include confirmation of fuel behavior at high operating temperatures and qualification of improved fuel particle coating material and other high temperature material applications.

3.4 Gas-Cooled Fast Reactor Systems

The GFR systems scored “better” to “much better” compared to the referenced ALWR. Of particular note are (1) the improved fuel utilization stemming from a high conversion ratio and high thermal efficiency and (2) minimized content of long-lived radioactive nuclei in the waste. Important uncertainties, in addition to those identified for PBRs and PMRs, include fuel qualification at high burn-up and fast neutron fluence, materials qualification for high fast neutron fluence, confirmation of the extent of active safety systems required, and development of designs with acceptable safety performance.

4. CONCLUSIONS AND RECOMMENDATIONS

The results of the screening-for-potential evaluations may be summarized as follows:

- Each of the four concept sets offers reactor systems with the potential to fulfill the goals for a Generation IV nuclear energy system.
- A technical basis exists to conclude that many of the GCR systems would not incur fuel damage under accident conditions and could be certified to meet protective action guidelines at the site boundary. As a consequence, a high-pressure, conventional-type containment is considered unnecessary, and the size of emergency planning zone (EPZ) could be greatly reduced compared to the reference ALWRs, with the EPZ anticipated to extend only to the site boundary.
- This is achieved using refractory-coated fuel particles (e.g., using silicon carbide coatings) and a limited size core at low power density. The particle fuel consists of a spherical kernel of fissile or fertile fuel material encapsulated in multiple coating layers. The multiple coating layers form a miniature, highly corrosion resistant pressure vessel and an essentially impermeable barrier to release of gaseous and metallic fission products. This capability has been demonstrated at temperatures in excess of those that are predicted to be achieved under worst-case accident conditions.
- The GCR systems provide thermodynamic conditions that support a broad spectrum of potential applications, ranging from electrical power generation to alternate fuel production (e.g., hydrogen) that make substantial in-roads in reducing production of carbon gases released to the atmosphere. These systems achieve high thermodynamic efficiencies and have application potential well beyond the reference ALWRs.

For example, the pebble bed and prismatic fuel concept sets achieve outlet temperatures of about 850°C leading to thermal efficiencies approaching 48% for a direct Brayton cycle gas turbine. At these temperatures, hydrogen production is practical via steam reforming or IS processes. In the case of the Very-High-Temperature reactor system concept sets, temperatures above 900°C and potentially approaching 1200°C may be achieved, with thermal efficiencies approaching 60%. Additional potential high temperature applications, such as coal gasification and glass manufacture, are also possible, in addition to efficient production of hydrogen.

- The operating characteristics of the GCR systems accommodate use of a wide range of fuel cycles without changing the basic system design. The applicable fuel cycles range from low-enriched uranium to thorium-uranium, to plutonium alone. Prismatic block GCRs can also utilize the discharged and separated transuranic (TRU) waste from other reactors. The high burnup capability of the TRISO fuel particle allows for the fission of over 90% of the fissile plutonium in the TRU in a single irradiation cycle. Effectively, the prismatic block reactor can destroy a significant part of its own waste.

The thermal and epithermal GCR concepts provide the capability to achieve much higher burnups compared to the reference ALWRs, with the attendant capability to burn most of the minor actinides, thereby reducing the waste heat load and radio-toxicity.

- To achieve even greater sustainability improvements beyond the thermal GCR, a fast neutron spectrum GCR system can be used. This reactor system concept has a closed fuel cycle using high conversion or breeding of fissile materials. A breeding capability around unity may be of interest if a synergistic fuel cycle with LWRs is desired. The fast neutron spectrum reactor system provides a breeding capability that affords burning of about 70% of the energy of the natural uranium

compared to only a few percent for thermal systems. The fast neutron spectrum reactor can use depleted uranium as the make-up fuel, thus precluding further mining of natural uranium.

- The R&D needs for GCR systems range from investigation of selected technical uncertainties (e.g., fuel microsphere containment integrity for more mature reactor systems) to fundamental R&D (e.g., for fuel design and materials for Very-High-Temperature reactor system and fast neutron spectrum reactor system applications).
- A few of the submitted concepts do not adequately represent the important potential advantages for the GCR systems and are not recommended for further evaluation in the Generation IV Technology Roadmap.

All four of the concept sets are recommended to be carried forward as part of defining the important R&D needs. Most of the concepts within these concept sets offer variations on the reference concept that appear to be of interest for specific applications. However, a few of the submitted concepts do not adequately represent the important potential advantages for the GCR systems and are not recommended for further evaluation in the Generation IV Technology Roadmap. The specific concepts not recommended for further consideration are as follows:

- *G4, AdvanCed Atomic Cogenerator for Industrial Applications (see Appendix A)* – This concept is not intended for large-scale power production and does not meet the requirements of Generation IV in this regard.
- *G6, Simplified Gas-cooled Pebble Bed Reactor (see Appendix A)* – This concept is not intended for large-scale power production and does not meet the requirements of Generation IV in this regard. Additionally, the extent of definition is limited.

5. REFERENCES

Bennett, R., et al, "The Generation IV Technology Roadmap Project," ANS Winter Meeting 2001.

Levy, S., et al, "Technology Goals for Generation IV Nuclear Systems," ANS Winter Meeting 2001.

APPENDIX A

**Modular Pebble Bed Reactor (MPBR) Systems
Summary Report**

CONTENTS

ACRONYMS.....	23
A-1. INTRODUCTION.....	27
A-1.1 Background.....	27
A-2. CONCEPT DESCRIPTION.....	29
A-2.1 General Features of Pebble Bed Reactors.....	29
A-2.2 Brief Description of the Reference Concept Pebble Bed Plant Design.....	32
A-2.3 Special Features of Indirect Cycles and Modular Construction.....	34
A-2.5 Applications and Fuel Cycles.....	34
A-3 POTENTIAL OF THE CONCEPT SET FOR MEETING GENERATION IV GOALS.....	35
A-3.1 Evaluation against Criteria/Metrics.....	35
A-3.2 Summary of Concept Potential (Strength & Weaknesses).....	43
A-4 TECHNICAL UNCERTAINTIES (R&D NEEDS).....	44
A-5 TECHNICAL INNOVATIONS (DESIGN IMPROVEMENTS).....	48
A-5.1 Fuel Quality.....	48
A-5.2 Pressure Vessel Design.....	49
A-6 STATEMENT OF OVERALL CONCEPT POTENTIAL VERSUS R&D RISK.....	49
A-6.1 Specific Evaluations of Other Pebble Bed Reactor Concepts.....	50

Figures

A-1. Pebble fuel elements.....	27
A-2. AVR schematics.....	17
A-3. HTR-10 cross-section.....	28
A-4. PBMR Power Plant cutaway courtesy of PBMR, Pty.....	30
A-5. Conceptual layout of PBR.....	32
A-6. Schematic of plant systems.....	33
A-7. 1100 MWe plant layout – 10 modules.....	34
A-8. Potential income during construction.....	43

Tables

A-1. PBR nominal full power operating parameters ¹	33
A-2. Comparative bus bar cost assessment.....	40

ACRONYMS

ALWR	Advanced Light Water Reactor
AVR	Arbeitsgemeinschaft Versuchsreaktor (in Germany)
CHP	combined heat and power
ECCS	emergency core cooling system
GT-MHR	Gas Turbine – Modular Helium Reactor
HLW	high-level waste
HTR	high temperature reactor
IAEA	International Atomic Energy Agency
IHX	intermediate heat exchanger
INEEL	Idaho National Engineering and Environmental Laboratory
LLW	low-level waste
LOCA	loss of coolant accident
LWR	light water reactor
MEDUL	online, multiple-recirculating feeding system
MIT	Massachusetts Institute of Technology
MOX	mixed oxide (fuel)
NFI	Nuclear Fuel Industries
O&M	operation and maintenance
OTTO	once-through-then-out
PBR	Modular Pebble Bed Reactor
PBMR	Pebble Bed Modular Reactor (in South Africa)
PCIV	Pre-stressed Cast Iron Pressure Vessel
Peu-a-peu	“little by little”
PNP	Prototype Nuclear Process Heat
R&D	research and development

SGR	Simplified Gas-cooled Pebble Bed Reactor
THTR	Thorium Hochtemperatur Reaktor
VHTR	Very-High-Temperature Reactor

Appendix A

Modular Pebble Bed Reactors (PBR) Systems Summary Report

A-1. Introduction

A-1.1 Background

The modular pebble bed reactor (PBR) concept was originally been invented in United States but Germany began actual development of the technology in 1956. In 1959 an order was placed by the Arbeitsgemeinschaft Versuchsreaktor (AVR) to build a 15 MWe test reactor on the site of the Forschungszentrum Juelich, which performed the related research and development (R&D) together with industrial partners BBC/Krupp. Construction began in 1961, and first criticality was achieved in 1966. The AVR was operated for 21 years (until 1987) and generated 1.67 billion kWh in 123,381 hours of power operation, resulting in an overall capacity factor of 67.6% despite the multitude of experiments done in this plant to demonstrate the inherent safety of the high temperature reactor (HTR) design. The best performance was achieved in 1976 with an availability of 92%. In 1974, the reactor outlet temperature was raised to 950°C, which was needed to test Very-High-Temperature nuclear process heat applications (see Appendix C). The AVR was used for large-scale testing of pebble fuel (see Figure A-1) up to ultra-high burn-up and provided the experimental basis for code validation to be applied to modular HTR. The AVR was a unique design in that a steam generator was positioned above the pebble bed with upward helium core coolant flow, as shown in Figure A-2.

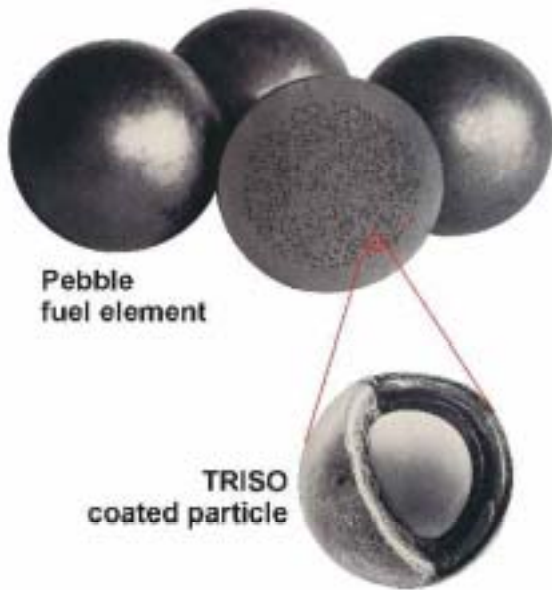

Figure A-1. Pebble fuel elements.

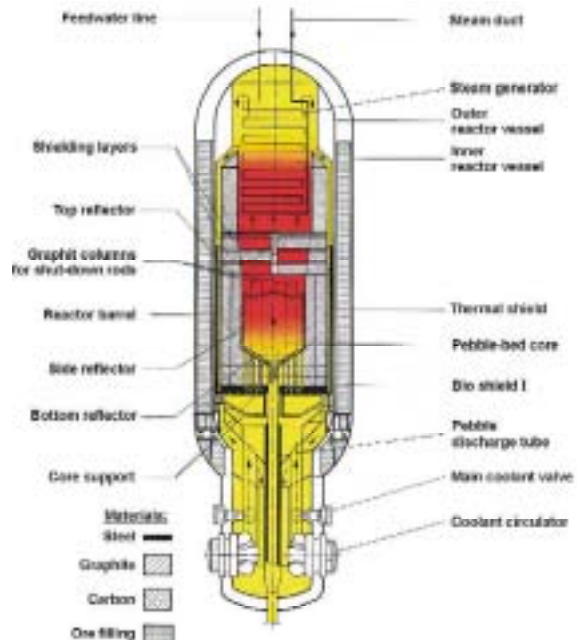

Figure A-2. AVR schematics.

The positive experience with AVR lead to the decision to construct a 300 MWe pebble bed demonstration plant (Thorium Hochtemperatur Reaktor [THTR]) using thorium/uranium mixed oxide (MOX) fuel at Hamm-Uentrop in 1971. The reactor core consisted of 675,000 pebbles in a core

measuring 5.6 m in diameter and 6 m in height, controlled not only by reflector rods (as AVR) but also by additional rods inserted directly into the pebble bed. The reactor was an integrated design with a core and steam generator housed in a single cavern pre-stressed concrete vessel. Construction suffered from many changes during the licensing procedure so that the plant was not commissioned until 1982. It reached full power in 1985 thus demonstrating the feasibility of large pebble bed reactor cores with downward helium coolant flow, as is now the case with modern designs of pebble bed reactors, such as the South African Pebble Bed Modular Reactor (PBMR).

The THTR was shut down in 1988 after having overcome initial prototypical problems while accumulating 16,410 operational hours and 2,891,000 MWhr of electricity generation. As a result of the good fission product retention in the BISO-coated particles, the personnel dose only amounted to 0.044 manSv (4. manrem) through 1986 despite several inspections and repairs. This value is about two orders of magnitude smaller than that of older light water reactors (LWRs) and more than ten times lower than new LWRs.

The most recent pebble bed reactor to be built is the Chinese HTR-10, which achieved first criticality in December 2000. The reactor core and steam generator are housed in two steel pressure vessels (see Figure A-3). These two vessels are joined by a connecting vessel containing concentric hot and cold gas ducts. The operating temperature of the steel pressure vessels is approximately the same as the cold helium (about 250°C) coming from the circulator situated over the steam generator tubes in the same vessel.

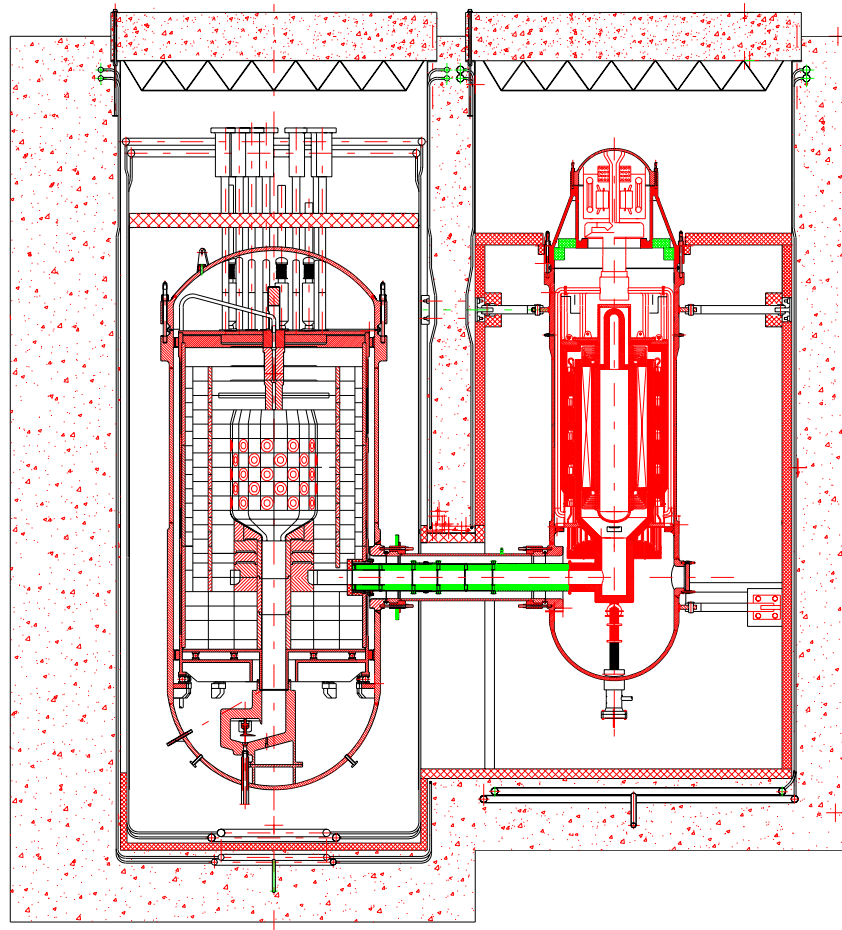

Figure A-3. HTR-10 cross-section.

Despite the small power size of 10 MW, the HTR-10 vessel diameter is approximately the same size as a 250 Mwth plant. The size of the HTR-10 vessel will be able to demonstrate the key principle of modular reactors by passive dissipation of decay heat from the pebble bed core (via the core structures and the vessel) to the coolers arranged in the core cavern. In the future, the HTR-10 will be operated up to 950°C for investigating diverse power generation systems (e.g., gas turbine) and nuclear process heat applications.

In summary, it can be stated that the technology of HTR based on pebble fuel has a sound foundation of knowledge by 45 years of development and by the long-term operation of AVR. The main features being applied in recent designs of modular HTR have been proven to such an extent that near-term deployment seems to be possible, as undertaken by the PBMR project in South-Africa and in the United States (see *A Roadmap to Deploy New Nuclear Power Plants in the United States by 2010*, prepared for U.S. Department of Energy, October 31, 2001). The HTR-10 is available to validate design codes in relevant scale and to continue the development towards more innovative technologies and new applications of nuclear process heat. This trend is being supported by R&D programs in Japan, Europe, China, South Africa, and the United States (at the Massachusetts Institute of Technology [MIT] and the Idaho National Engineering and Environmental Laboratory [INEEL]) offering a sustainable technology implementation.

The pebble bed core of modular HTR represents a universal heat supply system for different applications (e.g., electricity generation, Combined Heat and Power [CHP], nuclear process heat) and different designs such as steam cycle, combined cycles, direct gas turbine cycles, and indirect gas turbine cycles. The type of power conversion systems do not primarily depend on the type of core and can be principally applied to both pebble bed and block type cores.

Steam cycle HTR can be regarded as state-of-the art and ready for commercial use, whereas gas turbine applications represent a promising innovative solution profiting from former HTR projects like Power Plant with High Temperature Reactor and Helium Turbine, Direct Cycle Helium Turbine Plant at Energie-Versorgung Oberhausen, High Temperature Helium Turbine Test Facility – Versuchsanlage, and Prototype Nuclear Process Heat (PNP). As the direct cycle will be described in connection with block type reactors (e.g., the Gas Turbine – Modular Helium Reactor [GT-MHR], see Appendix B), the emphasis here will be on an indirect cycle as a possible future alternative. The South African PBMR represents the counterpart to the GT-MHR design and is discussed in the framework of near-term deployment Projects.

A-2. Concept Description

A-2.1 General Features of Pebble Bed Reactors

The new pebble bed reactor concepts all use TRISO-coated microspheres in a 6 cm ball configuration as the fuel form (Figure A-1). In contrast to the block type fuel, the coated particles are homogeneously distributed within the spherical fuel matrix acting as moderator. This leads to significantly lower central fuel temperatures (~1100-1200°C) as compared to the fuel compacts (~1350°C). There are two generic concepts for pebble bed reactors in terms of refueling. The most common is the online multiple-recirculating feeding system (MEDUL) in which pebbles are continuously removed, controlled with regard to their burn-up and mechanical integrity, then transported back to the top of the reactor core if they did not reach the burn-up target. Fresh fuel is only added as needed to maintain criticality (Figure A-4). The other types are the once-through-then-out (OTTO) concept where the pebbles only perform one passage through the core and the *peu-a-peu* scheme in which fuel is added to maintain criticality then completely discharged and replaced when the vessel is full. For the on-line

refueling designs, the pebbles are circulated by gravity in the core, which is surrounded by a graphite reflector, and pneumatically transported in the fuel handling system. Normally, the graphite reflector is not easily exchangeable although some future designs contemplate replacement.

The main advantage of the pebble bed system is that there is practically no excess reactivity and no shutdowns for refueling due to the on-line refueling system. On the other hand, the operational history of the fuel balls is governed by stochastic processes and not predictable in a deterministic way as is the case with block type fuel. Therefore, the flow of pebbles within the core has a direct impact on the neutronics of the system. The zoning of the core can be done by different feeding lines that insert the recirculated and fresh pebbles or graphite balls at different radial positions on top of the core. The chemically and neutronically inert helium coolant prevents corrosion of the graphite fuel and structures as well as not creating adverse reactivity effects in the case of loss of coolant accidents (LOCAs). In case of loss of active core cooling, even in combination with depressurization accidents, the decay heat is mainly transmitted via conduction and radiation from the core to the surrounding structures to the ultimate heat sink outside the pressure vessel. The pebble bed core is designed to achieve maximum fuel temperatures below 1600°C, which is the target for the actual coated particle design at a mean burn-up of about 80,000 MWd/t. Much higher burn-ups (>120,000 MWd/t) have been achieved in AVR without fission product release during normal operations. Improvements in coated particle design using innovative coatings (e.g., ZrC instead of SiC) are being studied to increase this temperature. In addition, new fuel designs that will allow higher burnups are also being researched. Retaining fission products in the coated particles at temperatures above 1600°C will allow for higher power capability and/or enhance safety margins.

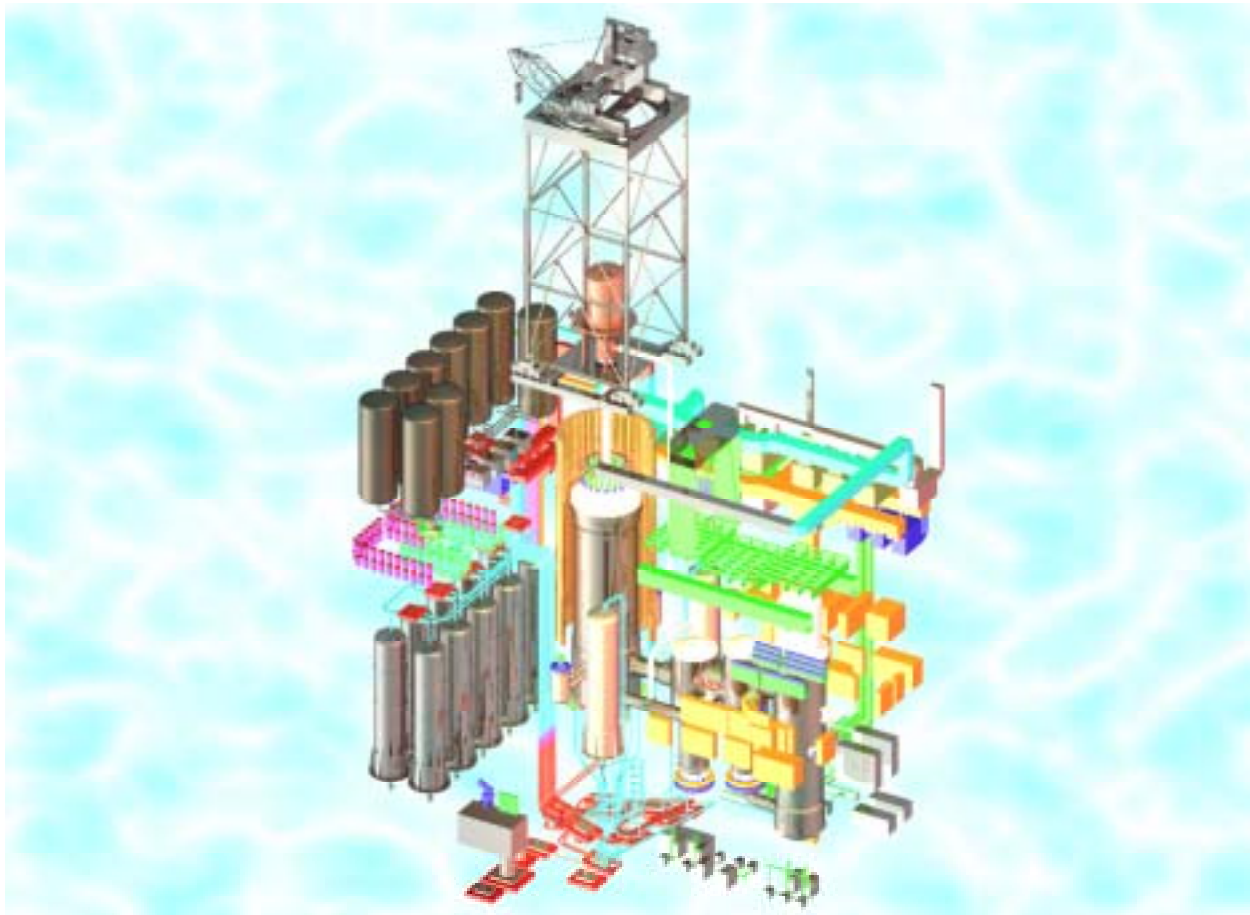

Figure A-4. PBMR Power Plant Cutaway Courtesy of PBMR, Pty

The HTR reactor is an epi-thermal spectrum reactor with graphite reflectors on all sides. The base core design for several of the gas-cooled pebble bed concepts is the former German HTR Module Reactor with 200 MWth at 750°C coolant outlet temperature. The South African PBMR core design employs a dynamic annular central graphite column of pebbles surrounded by a small mixing zone of graphite and fuel pebbles, which is surrounded by a pure fuel pebble zone to increase the power of the plant. Another annular core option proposed—with even higher power—would be the use of an inner solid graphite column, as proposed in the Annular Pebble Bed Reactor (APBR) concept (G17). This concept would allow for the same power size as block type reactors (600 MWth). The outer diameter of such a core would still be about the same size as that of the THTR. Additional tests would be necessary to study the flow of pebbles in such a geometry.

The pebble bed concepts submitted are:

1. *C02 – Modular Pebble Bed Reactor (PBR)*—This 250 MWth reactor uses the dynamic annular core concept to generate approximately 115 MWe through an intermediate helium to helium heat exchanger. The unique feature of the design is that the balance of plant is to be modularized in small size units to be factory built and site assembled. The layout of the balance of plant is in horizontal components that would be replaced rather than repaired. The PBR is an on-line refueling plant. Since this plant has an IHX, it can be directly used for many process heat applications.
2. *G4 – AdvanCed Atomic Cogenerator for Industrial Applications (ACACIA)*—ACACIA is a small 40 MWth pebble bed reactor that is being proposed for the industrial market. It provides 13.6 MWe through a direct gas turbine cycle with the residual heat converted into 220°C steam using a conventional steam generator for process heat applications. The core design is a *peu-a-peu* system in which fuel is added during operation as the core reactivity decreases. The reactor vessel is sized such that the fuel would not have to be discharged until after 10 years of operation. The net thermal efficiency for the plant including the process heat is expected to be 64 %.
3. *G6 – Simplified Gas-Cooled Pebble Bed Reactor (SGR)*—The SGR is a small, transportable, modular reactor design to be factory built in up to 3 “containers” that would house key components. This reactor is designed to produce 10 MWth and 5 MWe using an indirect steam cycle. The power size can range up to 40 MWth. The unique feature of this design is that it is coupled with an Enhanced Safety Information Management System that would monitor and control the output of the plant. Food irradiations are also planned for this type of reactor.
4. *G15 - Re-Configurable Deterministically-Fueled Pebble-Bed Modular Reactor*—This version of the pebble bed employs fuel channels into which pebbles are selectively placed to physically assure defined fuel loadings. It retains the capability of online refueling. The size of the reactor is not yet defined, but it is assumed to be the standard 250 MWth plant.
5. *G17 – Annular Pebble Bed Reactor (APBR)*—This design essentially employs the PBMR annular core with a solid inner graphite column. Cast iron blocks that up the reactor vessel, held together by multi-filament tensioned tendons. The stated advantage of this approach is that pressure vessel failure is eliminated since the venting of the cast iron blocks would relieve high pressures, should they occur. The other advantage is that the reactor vessel can be assembled on site (thus avoiding the shipment of such a large reactor vessel) and can be more easily dismantled. The vessel allows for an integration of a passive cooling system to optimize the removal of the decay heat in a more direct and efficient way. The Advanced Pebble Bed Reactor targets to larger power size (~400-600 MWth) for different applications (electricity production, CHP, Nuclear Process Heat, thermochemical water splitting etc.).

A-2.2 Brief Description of the Reference Concept Pebble Bed Plant Design

Of the designs submitted, the PBR concept (C02) was selected as the reference concept for generic review. This concept provides new features and applications and is most developed in terms of design and economic information, making it suitable for evaluation. The fundamental core design is based on the annular core concept proposed for the South African PBMR with direct cycle and separate high-speed turbo compressors and a low speed turbo generator (different from the GT-MHR approach with a low speed single shaft turbo compressor). Except the nuclear heat supply system, the rest of the PBR plant design is uniquely different from other pebble bed or block type projects.

This modular pebble bed reactor is a 250-megawatt thermal, 115-megawatt electric, indirect cycle, gas turbine power plant. To avoid radioactive contamination on the power conversion system, facilitate process heat applications, and ease maintenance of the balance of plant, the design uses a helium-to-helium intermediate heat exchanger (IHX) developed by the German PNP Project for temperatures up to 950°C. The design concept is focused on modularity principles in the design of the reactor, IHX and power conversion unit. Modularity features of this design allow major components to be manufactured in a factory and shipped in modules to the site. This is particularly true of the power conversion unit, where the turbines, compressors, generator and recuperators are preassembled into individual modules that can be shipped in several pieces that would allow for “Lego”-type assembly at the site. This new approach to construction of nuclear power plants is a major departure from other concepts being proposed. In addition, the design with the IHX will allow the direct deployment of process heat applications, such as hydrogen generation and desalinization for markets throughout the world. Thus, the IHX and the associated hot gas ducts can be seen as key components for a variety of applications while still using a standardized nuclear island. At the proposed temperatures of 850°C, the IHX is feasible with available high temperature alloys.

The basic design of the plant is shown in Figures A-5 and A-6 with key operating parameters shown on Table A-1. The reference core design utilizes the PBMR annular core design developed in South Africa and Germany with assembled block graphite reflectors and an online MEDUL refueling system.

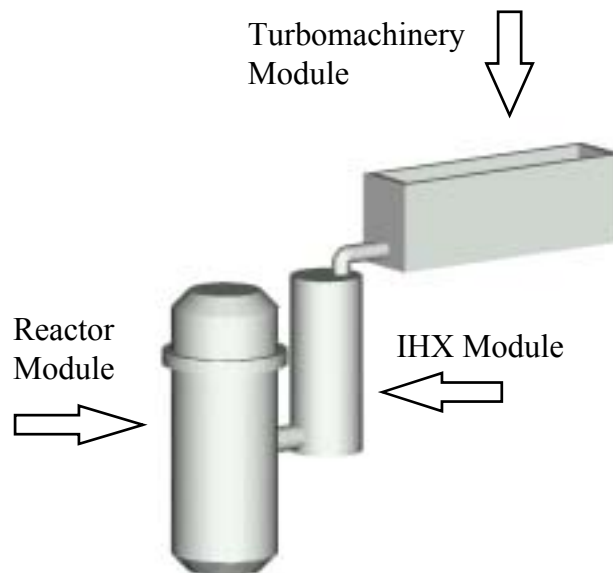

Figure A-5. Conceptual layout of PBR.

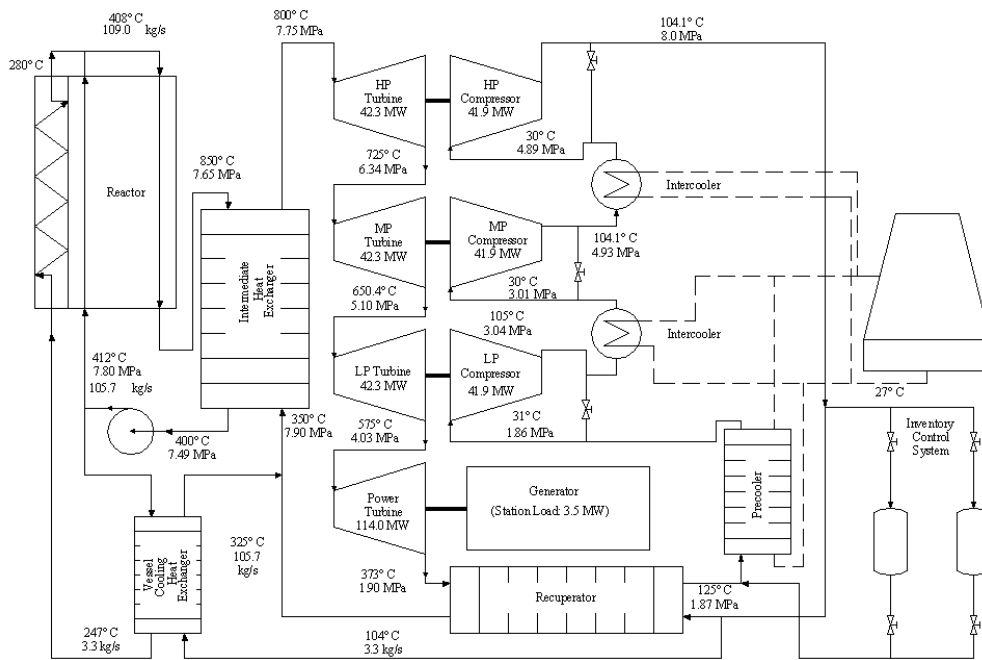

Figure A-6. Schematic of Plant Systems

Table A-1. PBR Nominal Full Power Operating Parameters

Reactor Power, MWt	250
Core Inlet/Outlet Temperatures, °C	412/850
Core Inlet/Outlet Pressures, MPa	7.8/7.65
Helium Mass Flow Rate, Kg/s	120
Turbine Inlet/Outlet Temperatures, °C	800/373 (4 turbines)
Turbine Inlet/Outlet Pressures, MPa	7.75/190
Recuperator Hot Side Inlet/Outlet Temps, °C	373/125
Recuperator Cold Side Inlet/Outlet Temps, °C	104/330
Net Electrical Output, MWe	110
Net Plant Efficiency, %	44

1. These values are preliminary based on an unoptimized design using only proven technology.

A-2.3 Special Features of Indirect Cycles and Modular Construction

Two options under currently under development: a direct cycle helium gas turbine system being developed for PBMR and GT-MHR, and an indirect, helium-to-helium IHX gas turbine system being developed by MIT. These options open a multiplicity of applications, especially when using the heat of the bottom cycle for process steam due to the low contamination of the intermediate circuit. Water ingress accidents can be completely ruled out for this approach. The IHX is a versatile component allowing for quasi-conventional design of the secondary circuit (closed, open or combined cycle) and different process heat applications. Direct, indirect, combined, and open cycles each have their advantages and disadvantages with the key success criteria being the cost per kilowatt-hour. The indirect cycle proposed in the PBR Concept is shown in Figure A-5. Conceptually, the turbo machinery module could be factory built as one or several units and trucked to the site for simple assembly. While still conceptual, the new approach to building nuclear plants is to minimize site work by making much of the plant as modularized as possible. The flow schematic of the PBR plant is shown on Figure A-6.

Depending on the user requirements, the proposed layout ranges from single or twin stations up to an 1100 Mwe plant, as is shown on Figure A-7. The concept calls for a single control room operating all 10 units through an advanced control system, thus employing many of the multi-plant lessons of modern, gas-fired power plants in terms on modularity and automatic operation. Construction plans and schedules were developed to refine the cost estimates and schedule expectations. The preliminary schedule calls for bringing the first unit on line in slightly over 2 years with additional modules coming on line every three months thereafter. A unique feature of this modularity approach is that it allows for the generation of income during construction, subsequently reducing interest that would be incurred during construction of an equivalent 1100 Mwe plant.

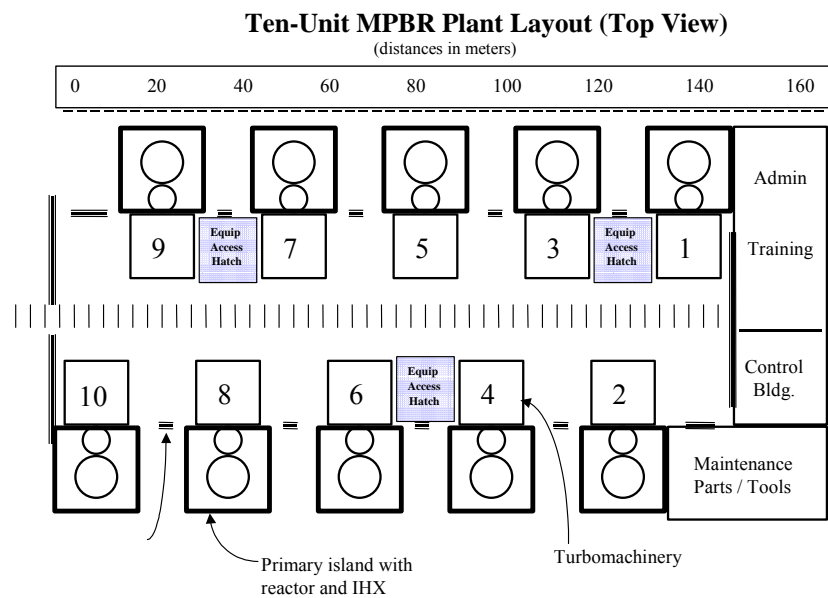

Figure A-7. 1100 MWe Plant Layout – 10 Modules

A-2.5 Applications and Fuel Cycles

Applications for high-temperature pebble bed reactors depend on the ability of the plant to recover excess heat or to direct high-temperature exhaust helium into process heat applications. This will largely depend on the available materials that are presently qualified to about 850-900°C to withstand the

projected lifetime of the plant of about 40 years. Applications of higher average coolant temperatures (e.g., hydrogen generation) are discussed in Appendix C. Indirect cycles are more amenable to direct application of process heat applications due to the low contamination of the secondary cycle and exclusion of water ingress accidents. The concepts using indirect cycles are: C02 and G6.

Others either have not specified or can use IHXs (G17), as well. One concept (G6) suggested using the small pebble bed plant for food irradiation without sufficient details as to how this would be accomplished. The fuel cycles possible for most, if not all pebble bed reactors are uranium (low enriched), uranium-thorium, uranium-plutonium, plutonium-thorium, and plutonium for burning of excess weapons plutonium. Due to the continuous refueling, there is little excess reactivity and no need for burnable poison that degrades the neutron economy.

A-3 Potential of the Concept Set for Meeting Generation IV Goals

A-3.1 Evaluation against Criteria/Metrics

A-3.1.1 Sustainability.

A-3.1.1.1 Sustainability 1: Long-Term Fuel Supply.

- SU1-1 – Fuel Utilization [+]. The PBR is an epi-thermal spectrum reactor that has the potential of using uranium, thorium and plutonium fuels. The TRISO fuel design permits very high burnups—approximately double that of LWRs—further enhancing fuel utilization. The proposed basic design will use 8% enriched uranium, but other fuel cycles are possible. While not an infinite supply of fuel, the availability of the fuel should not be an impediment to deployment, especially when taking the use of thorium or a symbiosis with fast spectrum reactors into account.
- The PBR is more efficient than the AP-600 Advanced Light Water Reactor (ALWR), 44% vs. 32%, resulting in less fuel consumption per kwhr. The higher thermal efficiency of pebble bed reactors and ability for CHP applications due to its higher operating temperatures over that of LWRs is the predominant advantage in fuel utilization.
- SU1-2 – Fuel Cycle Impact on the Environment [++]. The proposed PBR concept is a once through fuel cycle not incurring the environmental impact associated with reprocessing operations. It will require more mining of basic ore, but this may be balanced by higher thermal efficiencies and higher burnup on the fuel. The higher thermal efficiency also reduces the thermal discharges to the environment. The areal power density of a 10-module PBR plant is also less than an AP-1000 (it could be as much of a factor of two less for the power plant footprint).
- SU1-3 – Utilization of other Resources [=]. Helium and graphite are needed resources for the PBR, and both are available. Helium is a byproduct of natural gas recovery and graphite is a byproduct of oil recovery. The government may consider capturing helium that is now vented to the atmosphere. There are no known scarce materials used in the PBR.

A-3.1.1.2 Sustainability 2: Waste Management [+]

- SU2-1 – Waste Minimization [+]. Experience with pebble bed reactors indicates that its low-level waste (LLW) stream is exceedingly low due to the use of an inert gas (helium).

Preliminary analyses indicate that the high-level waste (HLW) stream for a once through disposal fuel cycle require less space in a repository on a kilowatt hour basis than do LWRs due to the PBR's higher burnup, higher thermal efficiency and lower heat loads per container. These benefits are attributed to the low power density core and the 'dilution' of the spent fuel within the moderator/fuel matrix.

1. Mass and Volume of SNF/HLW Sent to Repository [+]. The spent nuclear fuel/HLW burden can be estimated by C_i , volume, or mass. In terms of fuel volume, the PBMR has ten times that of AP-600 for a given energy production. However, PBMR fuel may be directly disposable due to the very low leaching rate of the graphite spheres, thereby reducing the overall waste package volume compared to the AP-600. The volume of space occupied in the repository would also be smaller due to the lower heat load per package and the higher thermal efficiency and higher burnup, resulting in a lower space occupied in the repository per kilowatt-hour generated.
 2. Decay Heat Thermal Output [+]. On a per package basis the decay heat load would be less due to the more dilute nature of the fuel. Overall, the decay heat burden per kilowatt-hour would be less due to the higher thermal efficiency of the pebble bed.
 3. Activity Measures [+]. Curies are lower for PBMR because of the higher thermal efficiency of the reactor. Similarly, the mass of heavy metal would be lower for PBMR because of the higher thermal efficiency and the higher initial enrichment. The overall actinide burden would be lower for the PBMR because of the higher burnups experienced.
- SU2-2 - Environmental Impact [+]. The reference cycle for the PBR is for a once through fuel cycle not requiring the construction of fuel reprocessing facilities; hence, no environmental impact is associated with these facilities. The fuel may be suitable for direct disposal due to the leaching resistance of the graphite and ceramic coatings. Further research on leaching and corrosion behavior is necessary to allow for long-term predictions. What is known is that the leachability of fission products from the pebble fuel is much lower than for the LWR and as good as vitrified HLW.

Although this fuel can be reprocessed, it is very difficult due to the silicon carbide containment of the fuel particles. However, should waste stream minimization be desired, the concept should be reviewed for feasibility. Additional preprocessing will be required for reprocessing of pebble fuels. This includes removal of graphite matrix making up the pebble, removal of the pyrocarbon layers of the microsphere, and cracking the silicon carbide microspheres. New technology will have to be developed to avoid C14 release into the atmosphere if reprocessing is deemed to be desirable or economic.

Gas reactors have a unique capability to efficiently burn excess weapons plutonium and second-generation plutonium from LWR MOX fuels. If implemented this would help in the final disposition of plutonium.

Other factors affecting overall environmental impact reduction for the PBR over the ALWR pertain to its higher thermal efficiency, which translates into an overall lower environmental impact for the entire fuel cycle. Decommissioning environmental impacts are relatively lower due to the fact that helium gas is inert; thus, the residual contamination of a pebble bed reactor would be much lower compared to an ALWR.

Depending on the economics of graphite disposal, significant volume reductions for HLW and LLW are possible, making the impact of the overall plant life cycle on the environment significantly less.

- SU2-3 – Stewardship Burden [+]. Ultimately, all HLW, regardless of quantity and waste form, will end up in some type of geological repository. The significant stewardship issues relate to the integrity of the waste package and leachability of the waste form. Pebble bed fuel is an extremely low leachability ceramic material that does not require the use of high integrity packages to protect from water intrusion. The stewardship time is dictated by the materials disposed in terms of hazard and time. Even if actinides are mostly removed, some will remain after burning in special facilities. The stewardship “burden” for pebble bed fuel is significantly less due to the waste form given that the time factor will be the same. This will result in less material entering the human environment for geological time.

A-3.1.1.3 Sustainability 3: Non-proliferation [+]

- SU3-1 – Minimize Material Life Cycle Vulnerability [+]. Despite its on-line refueling feature, studies have shown that a normal operating pebble bed reactor is an unlikely proliferation target largely due to the low uranium loading of the pebbles and the very large number of pebbles that would have to be diverted to accumulate 8 kg of plutonium. If diversion were attempted, close to 800,000 pebbles would need to be secretly diverted for this on-line refueling system to produce plutonium of interesting isotopics for weapons use. At discharge, the isotopics are not good for weapons, but in any case to accumulate 8 kg would require the secret diversion of over 250,000 pebbles. Both are detectable under any International Atomic Energy Agency (IAEA) monitoring system now in place. There is the issue of special natural or depleted uranium pebbles that could be inserted for one pass through the reactor. This would take close to 3 years to accumulate about 15,000 pebbles of interesting plutonium isotopics that will need hardware changes in the defueling system for separating the different pebbles. This hypothetical potential for manipulation will necessitate extrinsic IAEA measures to ensure that introduction of these pebbles does not occur and any diversion is detected. These extrinsic measures are similar to those now employed in LWRs and spent fuel storage facilities. In addition this fuel, with its microsphere coating of silicon carbide, is more difficult to reprocess than ALWR fuel requiring additional front end processing that has not been commercially demonstrated as being effective or reliable. Lastly, pebble bed reactors can be operated using a denatured thorium/uranium-233 cycle, which would reduce the proliferation risk further if required.
- SU3-2 – Facilitate Material Accounting and Application of International Safeguards [+]. The PBR has only three possible points for diversion of fuel in the operating plant. Each of these points, in what is otherwise a closed system, can be easily instrumented with remote sensing devices to detect diversion or introduction of production pebbles. A study recently completed at MIT demonstrated that using today’s technology extrinsic barriers could be readily applied to the pebble bed reactor to alert the international community of any intentional misuse of the reactor for weapons purposes. It should also be noted that should a nation go to the trouble of diverting pebble bed fuel for weapons production, they would also require a sophisticated reprocessing and nuclear infrastructure that could be used to make weapons grade fuel directly and more simply.

- *SU3-3 – Unique Characteristics [+].* The most unique characteristic of pebble bed reactors relative to non-proliferation is the huge number of pebbles that would have to be secretly diverted to accumulate a sufficient amount of plutonium for weapons production even if special pebbles were inserted. This is a considerable advantage over LWRs in which this same amount of plutonium could be found in one or two fuel assemblies.

A-3.1.2 Safety and Reliability.

A-3.1.2.1 Safety and Reliability – 1: Excel in Safety and Reliability [++].

- *SR1-1 – Reliability [+].* Due to the smaller number of components in the pebble bed reactor in comparison to an ALWR, the overall reliability should be higher (no emergency core coolant system [ECCS] or other water management systems required for safety). The overall simplicity of the pebble bed design should increase reliability over ALWRs. The AP-600 has an 18-month operating cycle compared to an on-line refueling system that has outages every 5 to 6 years, resulting in overall higher capacity factors for the PBR. A 90% capacity factor was assumed as a minimal value. The design of the PBR employs a replacement versus repair strategy that should also improve overall reliability by decreasing the forced outage rate since on line replacements of components can be made. The number of technical specifications that would limit operations would be considerably fewer since there are fewer safety systems required for operation. The most problematic part of the plant is the online refueling system, which the Germans have shown to be highly reliable based on their experience at the AVR and THTR. As to reliability, the plant, in either a direct or indirect power conversion cycle, is expected to require outages every 5 to 6 years for balance of plant overhauls. High temperature turbines and compressors for helium application are less of a design challenge than comparable air systems and are smaller in size.
- *SR1-2 – Public and Worker Safety – Routine Exposures [++].* High-temperature, helium-cooled reactors have several safety and reliability advantages that are inherent in the design, especially for small modular units such as the pebble bed. First, they use a very low power density core. Second, they provide a strong silicon carbide containment for each fuel particle containing 0.0007 grams of uranium. Third, the use of an inert gas as a coolant reduces corrosion in the plant that contributes to waste and exposure to workers. Fourth, due to the design of the core, analyses and tests have shown that the core will not melt under LOCA conditions, even without any active or passively acting systems. Fifth, there is nearly no excess reactivity for pebble bed reactor cores due to on-line refueling.

An issue relating to minimizing worker exposure is to the diffusion of silver 110m through the silicon carbide, which would affect maintenance exposure for direct cycle plants. Present analyses indicate that most of the silver for a direct cycle system will plate out on the recuperator and in the IHX of an indirect cycle machine. Research is now underway to limit the diffusion of silver 100m through the microsphere. In this case, the indirect cycle is deemed preferable to the direct cycle to limit worker exposure. The added value of the pebble bed is the inert helium coolant, which produces essentially no LLW or activation products that create worker exposure issues. This is a major advantage of helium-cooled reactors. Overall, workers are expected to have at least a factor of ten reduction (man-rem per year versus hundred man-rem per year), compared to the AP-600, for equivalent power production.

- SR1-3 – Worker Safety – Accidents [+]. The pebble bed reactor does not have high temperature and pressure steam conditions to deal with during normal operations that could pose a risk to operators. The helium gas is at high pressure and temperature, but it is judged to be less of an overall energy risk. In addition, the corrosion products and crud associated with water systems is not present, thus reducing the risk of overall exposure during accident conditions.

A-3.1.2.2 Safety and Reliability – 2: Low Likelihood of Core Damage [++]

- SR2-1 – Robust Engineered Safety Features [++]. The plant does not require engineered safety features since the basic design is deterministically safe without them. The safety is included in the inherent design of the fuel and the plant. This is a unique and demonstrated natural feature of low power density pebble bed reactors. Tests and analyses have shown that under LOCAs the core will not melt and fission products will be contained in the coated particles. This makes the issue of fuel quality a critical safety function that will require a quality assurance and inspection program for verification. Tests conducted in Germany show that the fuel microspheres will maintain integrity even under complete corrosion of the outer pyrocarbon layer and the graphite matrix of the pebbles up to about 1450°C due to the strength of the silicon carbide. The German AVR reactor suffered a major water ingress event with the failure of their steam generator located above the core. Once dried, the reactor was restarted.

In licensing procedures in Germany, it was concluded that the pebble bed reactor will have no difficulty in meeting the 10^{-5} /yr core damage frequency, with a much lower number expected.

- SR2-2 – System Models Have Small and Well-Characterized Uncertainty [++]. Analyses in Germany, South Africa, and the United States (at MIT) have shown that even under very conservative assumptions of core heat removal under LOCA conditions that the core does not melt. Tests have been performed in Germany to confirm this finding. The physical design of the plant with a low power density core essentially ensures that by only considering heat conduction and radiative heat transfer fuel-melting temperatures are not attained, even without any active or passively acting ECCS. The peak fuel temperatures calculated for a LOCA are almost 2000°C below the uranium oxide fuel-melt temperature. Thus, the margins are high, and the analysis uncertainty should be very low.
- SR2-3 – Unique Characteristics [++]. No mechanical systems are needed to prevent core damage. Decay heat removal is totally passive, with a low likelihood of attaining temperatures that damage fuel. There is very low surplus reactivity, and no water ingress is possible (for indirect gas turbine cycle). Time constants are very long due to the high thermal inertia of the core

A-3.1.2.3 Safety and Reliability – 3: No Offsite Emergency Response [++]

Due to all of the above factors, the emergency planning zone (EPZ) for the pebble bed reactor should be limited to the site with no offsite emergency response required. Analyses performed by PBMR (the South African developer of the pebble bed reactor) have shown that in the event of a design basis accident the EPZ is 400 meters. The radioactivity release from the core in a core-heat-up accident will not be the main source term but radioactivity accumulated during lifetime (e.g., dust). Containments are not considered to be necessary for

accident mitigation. Massive air ingress will be prevented either by confinement structures that limit air flow or by the use of alternate vessel types that exclude large breaks by design (e.g., Pre-stressed Cast Iron Vessels [PCIV]) assuming that principle can also be applied to the connection of the reactor pressure vessel and the component vessels.

- SR3-1 – Highly Robust Mitigation Features/Fission Product Barriers [++]. The pebble bed reactor bases its safety philosophy on low power density cores with fuel contained in tiny silicon carbide coated microspheres. This design is the inherent prevention and mitigation feature of pebble bed reactors. In addition, due to its online fueling, the excess reactivity required is relatively low, further improving overall safety. The design of the pebble bed reactor due to its fuel sphere arrangement has peak operating temperatures at about 1,200 C.

The pebble bed designs presently being considered include a low-pressure containment, referred to as a confinement. The designs call for venting in the event of a pipe break of a certain size to minimize damage to the structure and reduce the need for thick concrete structures. This is possible due to the basic reactor design and coated fuel particles such that in the event of a venting, release of radioactive materials is so low that no offsite emergency response would be required for this very low probability event.

- SR3-2 – Damage, Transport, Site Boundary Dose Understood [++]. There is a potential for carbon dust to carry air contamination in an accident. Source term, transport, and dose are understood to be similar to those of an ALWR. Due to the no core damage design, the issue of offsite dose becomes more easily bounded and less of a concern. Improvements remain to be made in understanding and achieving high quality manufacture of TRISO fuel. Predicting behavior of ceramic coatings under accident conditions still requires work to fully understand their behavior.
- SR3-3 – Societal Risk Comparable to Competing Technology. Not requested for this screen evaluation.

A-3.1.3 Economics.

A-3.1.3.1 Economics – 1: Life Cycle Cost Advantage [+]. The results of a comparative analysis performed by MIT using DOE data for high-temperature gas reactors and network interface unit cost estimates for competing technologies are shown on Table A-2.

Table A-2. Comparative Bus Bar Cost Assessment

Natural Gas	3.4 Cents/kWhr
AP-600	3.62
ALWR	3.8
Pebble Bed	3.3

These cost estimates show that on a comparative basis modular pebble bed reactors can compete with natural gas, the current low cost alternative. PBMR corporation’s analyses, based on their more detailed cost estimates for the South African market, show that the cost of their nth unit would be a factor of two lower than natural gas. Developers of the PMBR believe that the capital cost for their nth unit will be about \$ 1,000/kW with a resulting bus-bar power cost of 1.6 to 1.8 cents/kWhr. MIT’s conservative number assumes a capital cost of \$2,000/kWe, which is high by today’s standards. Still, the total cost of

power on a kilowatt hour basis (the basis upon which electricity is sold) is less than the cost of natural gas fired electricity due to lower fuel costs, shorter construction times, high thermal efficiency, low staffing levels, low maintenance costs, and high capacity factor associated with on-line refueling. As compared to the former MIT study further cost reduction can be expected when assuming a global supplier market and factory production of standardized modular units.

In the future, CHP applications will play a major role, being consistent with sustainability requirements for efficient use of energy and further reduction of bus bar cost in a competing electricity market. Due to the high operational temperature of the PBR, CHP will not lead to significant losses in efficiency for electricity production. Thus, PBR will also be competitive to gas-fired CHP stations, whereas LWRs will lose efficiency in the CHP mode.

- EC1-1 – Low Capital Costs [+]. On a per unit module, the capital cost for a 110 MWe plant is estimated to be between \$110 to \$ 200 million. This estimate may be reduced, however, through R&D targeted at further plant simplification. The MIT cost estimate of \$ 2,000/kW is not based on any bids received from suppliers. PBMR Pty has estimated the capital cost of the nth unit at about \$ 1,000/kW based on response to commercial requests for proposals. It is judged that the PBMR, at this time, is the best estimate of what might be expected. What is most important to the utilities making the decision to build Generation IV reactors is the final bus bar or total cost of power.
 1. Simplicity. The modular pebble bed reactor is a helium-cooled reactor that does not have complicated two-phase flow water systems to operate and maintain. The basic design does not require an ECCS, containment sprays, hydrogen igniters, chemical volume and control systems, etc. It does have a mechanical on-line refueling system with interfacing valves. Helium turbines and compressors are not complex – no blade cooling as is required for natural gas fired plants to produce electricity. As a machine, the PBR is much simpler than an ALWR.
 2. Scalability. The design of the PBR is rated at 250 MWth/110 MWe. Germans have built a 300 MWe pebble bed reactor that experienced some startup problems. The experience gained in Germany has led to a standardized pebble bed reactor sized to keep the control rods out of the core. This size turns out to be about 250 MWth with an annular graphite core, as is being developed by PBMR Pty. Thus, scalability of the basic power plant is not seen as a desirable requirement. The concept calls for building modules to meet demand based on a factory production model.
 3. Modularity. The PBR is designed to be modular. In the case of the PBR, modularity means building most of the plant in a factory with preassembled components shipped to the site for final assembly. It is not taking a large 1000 Mwe plant and making three still quite large 333 MWe electric plants that have to be constructed using conventional methods, leading to large amounts of site work (and rework) with attendant quality problems. In the case of the PBR, it is extremely modular with the entire power conversion unit being factory manufactured and shipped to the site in 21 truck shipments ready for assembly (MIT design study)
 4. Structural Volume. While structural volume is important in providing crude estimates of construction costs, it is not determinative. The final bus bar cost that incorporates all aspects of the cost of production is the final determinative feature. An assessment has been made of the areal power density and shows that

the PBR for an 1100 MWe, 10-module plant has an areal power density of approximately 10 kW/ft². The AP-1000 comparable number is 6 kW/ft². Thus, on a space occupied basis (another rough measure), the PBR is more efficient.

- EC1-2 – Low Financial Costs [+]. The concept of the PBR is factory manufacture with site assembly that allows for construction periods to be reduced to a 2-year time frame. This would decrease financial costs. If a larger number of modules are required, the sequencing of construction may allow for the generation of income as the units come on line during the total construction period. This would decrease financial cost as well, since income is being produced during construction rather than waiting 5 or 6 years for the completion of the unit.
- EC1-3 – Low Production Costs [+].
 1. Fuel Cost/kWhr. Fuel costs were assumed to be based on cost estimates for LWRs at about \$ 33 million per year. The capacity factor assumed was 90%, which for a 10-module plant is very conservative, meaning that one of the units will always be shutdown for some reason. A thermal efficiency of 45% was assumed.
 2. Operation and Maintenance Cost/kWhr. To estimate these costs, the MIT team developed a staffing plan to support operations and routine maintenance. Given the limited nature of the systems in the pebble bed reactor, the number of operating staff was estimated to be approximately 150. This is about double the South African estimate. Applying United States salary figures from the nuclear plant operating staff, an annual operation and maintenance (O&M) cost of \$31.5 million was assumed. PBMR Pty assumes a 10-unit module staffing level of 85 and a common outage support team. Given the expected levels of staffing and outage needs of the ALWR, it is estimated that the O&M costs are at about half those of competing light water technologies.
 3. Waste Management Cost/kWhr. Since the PBR is a helium-cooled reactor the generation of LLW is greatly reduced. Experience at Fort St. Vrain confirms this observation. Thus, the cost of LLW management is considerably reduced, as are the systems required for waste management. The cost of HLW is still based on the standard 1 mill/kwhr. As to spent fuel packaging costs, it is expected that they would be somewhat higher in the transportation segment but considerably lower in terms of packaging at the repository due to the nature of waste form—graphite having a very low leachability rate in water.
- EC1-4 – Low Development Costs [+]. Although this number is hard to quantify, clearly the greater than 25 years of work by the Germans and the more recent detailed design work by the South Africans strongly suggests that these costs would be relatively low. What needs to be demonstrated is more licensing related than pure development. The MIT project is focused on a more advanced design that would require more development, but these costs are incremental technology enhancements rather than radical design needs. Work being done by MIT is in the area of advanced fuels, components, and instrumentation and controls.
- EC1-5 – High Profitability [+]. While this may be an enticing metric, it is not useable since without knowing the market price of electricity, profitability is an unknown

quantity. Based on the cost projections provided and prices over the last year, the pebble bed technology, if market-based pricing is used, can be highly profitable, even more so than ALWRs since PBRs are less expensive generators.

- EC1-6 - Total Cost of Power/kWhr [+]. While not an explicit metric, it should be since it is the final measure of whether a plant will be built. The Technical Working Group on Gas is providing this information should it be included. MIT has used a standard Federal Energy Regulatory Commission model to develop a cost per kilowatt-hour, including all cost of generation from capital, operations and maintenance, and fuel. The results of this comparative assessment yield a 3.3 cents/kWhr assuming a 28-year levelized cost as a comparative measure. PBMR Pty and Exelon have run their own numbers on their plant based on bids for components received. PBMR estimates that this cost is about 1.8 cents/kWhr for South Africa, while for the United States market, Exelon is forecasting about three cents/kWhr.

A-3.1.3.2 Economics – 2: Comparable Financial Risk.

With the small truly modular units (defined as factory built modules that are site assembled), the PBR concept of the pebble bed reactor can conceptually have high assurance of maintaining the two-year construction schedule with less field rework. The economies of production rather than of scale provide additional assurance that the financial risk associated with the construction of a standard design that can be “cookie cut” either at one site or several sites should be minimized. Preliminary construction schedules have shown that the same number of megawatts can be installed in 10 incremental modules in the same time as a single large 1,100 MWe plant. The financial risk is lessened in the modular expansion approach for two reasons: (1) once the first unit is completed in two years, it generates a cash stream (see Figure A-8); and (2) should all the planned power not be needed, the other units can be delayed or added to meet demand, thus eliminating the “used and useful” challenge to overbuilding. Lastly, the initial capital investment for one module is relatively low (\$100 to \$200 million) as compared to several billion dollars for a large 1100 MWe electric station further minimizing financial risk and enhancing the chances of investment.

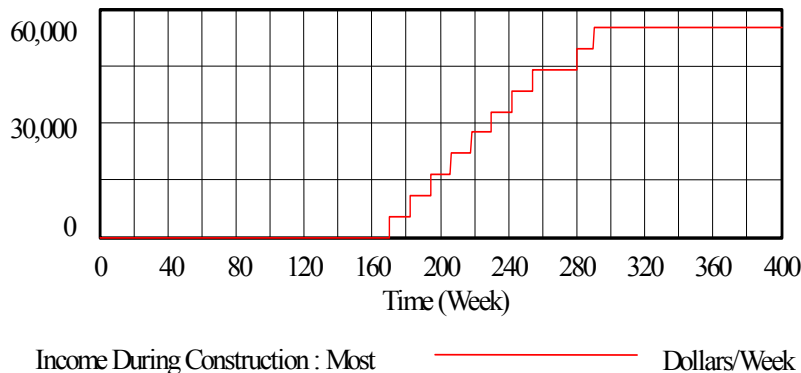

Figure A-8. Potential Income During Construction

A-3.2 Summary of Concept Potential (Strength & Weaknesses)

The fundamental bed pebble technology has been developed largely in Germany and adopted by South Africa, the United States (at MIT), and China, where a small 10-MWth/4-MWe (steam cycle) plant went critical in December 2000. The South African plan is to build a prototype plant in the next 5 years

ready for commercial operation. The proposed technology employs fundamentally German technology in fuel and plant design. Due to the relatively large difference in thermal capacity from the AVR (40 MWth/15 MWe) and the PBMR (250MWth/115 MWe), there is clearly some development work in the design of the reactor and the power conversion unit. On the other hand, additional valuable know-how is available from THTR with regard to much larger power, the downward coolant flow through the core, and diverse components in the 125-MWth range for each of THTR's six loops. PBMR and MIT are proposing the use of gas turbine technology with direct or indirect cycles, respectively.

The major strength of the technology is its safety in that analysis of a LOCA without an ECCS has shown that meltdowns are deterministically impossible. Also, preliminary economic analyses indicate the potential for competitiveness due to low fuel and operating and maintenance costs and the modularity potential allowing for mass production.

Due to its high operating temperatures, CHP applications are readily implemented, particularly with indirect cycle designs. If utilized, CHP would greatly improve overall thermal efficiencies, competitiveness, and value of this technology.

The other important strength of the technology is the ability to utilize a diverse fuel supply without major changes in the basic design of the plant. High-temperature gas reactors have operated using thorium cycles and are now being considered for the plutonium disposition mission. Pebble bed reactors are particularly flexible in this regard.

Since considerable reliance is placed on the integrity of the silicon carbide microsphere fuels, demonstration of the performance of the fuel and quality assurance of the fuel production facilities will be required if containments are to be avoided. To maximize the potential of this technology, high temperature materials will need to be developed as well as helium components, allowing for larger turbines, compressors, recuperators, and IHXs.

A-4 Technical Uncertainties (R&D Needs)

The generic innovation potentials (see Section A-5) of the pebble bed reactor technology are primarily focused on fuel performance and high-temperature resistant materials, as well as on component reliability and performance. Further R&D needs exist in the area of computer code validation of core neutronics, system behavior of direct/indirect gas-turbine cycles, and accident analyses. Some of these generic needs are summarized as follows.

- a. ***Fuel Performance.*** This element of the research plan involves all types of high-temperature gas reactors that depend on microsphere-coated particles for improved performance. Since fuel performance is an important element in the safety of pebble bed reactors and prismatic high temperature reactors, the fuel performance R&D needs are expanded in comparison to the other elements listed. It should be noted that Germany and Japan have successfully made TRISO fuel particles for their reactors. The following breakdown of R&D needs is aimed at developing a United States based technology for improved fuels. South Africa (PBMR) has chosen to replicate the German fuel fabrication technology for their plant.
 - ***Overall Performance Plan.*** Prepare a plan for fuel qualification of TRISO fuel for Generation IV gas-cooled reactors. Specify the performance requirements for fuel for a Generation IV gas-cooled reactor. Study the global optimization of reactor design (temperature, burnup, fluence, shielding, etc.), fuel design (as-manufactured quality, coating failure and fission product release in service, accident performance), site cost,

reactor costs, and fuel costs. Prepare a fuel product specification for Generation IV gas-cooled reactor fuel.

- *Manufacturing.* Establish a facility where coated particle fuel can be fabricated. Improve the coating process by reducing the number of defects created during the coating. Understand the role of the kernel and inner pyrolytic carbon in the formation of SiC defects. Optimize the design of the coater to reduce defects and improve coating performance. Develop an optimized coating procedure. Develop advanced methods and processes to eliminate as-manufactured defects after they have been created (i.e., methods beyond tabling and liquid elutriation which have been used for kernels and coated particles). Improve compacting processes. Develop high purity matrix material. Develop automated processes that retain as-manufactured quality. Develop processes that reduce the generation of manufacturing waste (e.g., no alumina, no filters for tars evolved during curing—think of using cure-in-place).
- *Reduce Coated Particle Manufacturing Costs.* Apply modern manufacturing techniques in coated particle manufacture. Engineer equipment and develop procedures to reduce manufacturing cost while maintaining fuel quality and performance. Establish a fuel manufacturing quality control procedure. Apply modern techniques to quality control testing. Identify new physical properties of fuel to measure, apply new measurement techniques, and determine their correlation with performance. Automate quality control testing to reduce manufacturing costs and allow larger numbers of items (kernels, coated particles, compacts, etc.) to be inspected. Develop a method to perform quality control tests on cure-in-place compacts (Note: potential large manufacturing cost saving). Develop a set of measurable as-manufactured fuel properties well-correlated with irradiation performance of coated particle fuel
- *Irradiation Testing.* Identify facilities and conduct irradiation testing, post-irradiation testing, and accident simulation testing of coated particle fuels.
- *Fuel Performance Modeling.* Prepare a plan to develop fuel performance and fission product transport models needed to license a Generation IV gas-cooled reactor. Measure, under conditions representative of core irradiation, the structural properties of coatings needed to construct a predictive fuel performance model. Measure, under conditions representative of core irradiation, the chemical phenomena affecting particle performance needed to construct a predictive fuel performance model, namely:
 - Internal gas pressure generation (fission products and carbon monoxide)
 - Escape of fission products from coatings as a function of temperature and burnup
 - Palladium attack of the coatings
 - Other fission product attack of the coatings
 - Carbon monoxide reactions with coatings.

Understand the processes limiting accident temperatures: (1) specialized models and empirical models, (2) specialized "first-principles" models, and (3) integrated performance models. Develop fuel performance models for accident conditions

(Note: understanding and characterizing accident condition behavior and providing models usable for licensing is one of the most important areas of work needed.).

- *Fission Product Transport.* Continue work on the impact of fission product plateout on operability, worker dose, and cost of remedial action to deal with fission products in the circuit. Complete the measurements of fission product transport in Generation IV coated particle fuel under representative conditions (Note: silver has to be given a high priority in these tests). Conduct integral tests regarding release of fission products from the fuel elements and compacts. Complete measurements of transport and deposition of fission products in the reactor circuit, with emphasis on the turbine (for direct cycle plants). Continue analysis of the whole sequence of release of fission products during normal and accident conditions.
 - *Development of Improved Fuel Designs.* Examine possible fuel particle design changes to allow higher burn-ups, temperature, and fluence. These could include: two SiC layers, ZrC, and alternate kernel stoichiometry.
 - *Closing the Fuel Cycle.* Plan for closing the gas-cooled reactor fuel cycle. Examine possibilities for reprocessing for waste volume reduction. Qualification of coated particle waste form for direct disposal.
 - *Waste Disposal.* Testing and modeling the behavior of irradiated coated particles in the repository environment. Develop fuel for transmutation of plutonium, minor actinides, long-lived iodine and technetium
 - *Other.* For prismatic reactors, develop coated particle burnable poisons such as boron carbide and erbium oxide.
- b. *Verification and Validation of Computer Codes and Models*—The most significant issue for the licensing is the verification and validation of computer codes used in the neutronics and safety analysis in performance of the plant. At present, such capability, if it exists, is extremely limited in the United States. Extended collaboration on an international basis can help to accelerate the transfer of relevant knowledge.
- c. *Air Ingress Events*—One of the significant issues for pebble bed reactors is the consequence of an air ingress event that could result from a break in one of the cooling ducts. Analyses have been done in Germany, Japan, and China that show this event is limited in consequence and has long time periods for intervention. A major Nuclear Regulatory Commission (NRC) and reactor research facility testing program initiative would include the development of a test scenario and validated computer codes that would allow for accurate modeling of air ingress events. Large test facilities as available in Germany (e.g., NACOK) can be used to study the phenomena and potential countermeasures in significant scale and to verify the computer tools. The development of corrosion resistant coatings on fuel elements and critical parts of the core structures should be fostered.
- d. *Water Ingress*—Water ingress is another transient that could occur should one of the water coolant loops of the intercoolers or pre-coolers break, allowing water to enter the primary system. This possibility is almost non-existent in an intermediate cycle pebble bed reactor since all the water is on the secondary side of the plant, but it will still be an issue for direct cycle plants even if the coolers are operated at low pressures on the water side. Codes and analyses that would demonstrate the behavior of the plant during a water ingress event need to be verified and validated.

- e. High Temperature Material Behavior—Since pebble bed reactors are high-temperature gas reactors, material behavior for long periods of time will require confirmation. Operation temperatures below 900°C can be realized with available material and knowledge. Higher temperatures (see Appendix C) need considerable material qualification and development of new high-temperature alloys or fiber reinforced ceramics and compounds. Desired pebble bed target outlet temperatures of 950°C will require new American Society of Mechanical Engineers code cases for deployment in the United States.
- f. Transient Behavior of the Plant—Several transients could affect the safety of the plant, such as loss of load, rod ejection, seismic events, spontaneous deblading, and turbine overspeed to name a few. These transients need to be analyzed for their impact on the core. Normal operating transients will need to be assessed to evaluate core feedback coefficients, behavior under LOCA conditions, xenon oscillation potential, internal shockwaves, etc. All these transients will need to be baseline tested and verified using approved NRC models prior to licensing.
- g. Power Distribution Assessments—At present, pebble bed reactors and other high temperature reactors do not have online capability to measure power distributions. While this is not judged to be an important criterion due to the nature of these reactors, MIT is working on the development of a technology to allow for online measurement or confirmation of core power distributions.
- h. Containment—Present pebble bed reactor designs rely on fuel containment in the microsphere fuel particles. Analyses and tests show that the fuel is extremely robust and that LOCAs without any active core cooling do not result in core damage or significant release of fission products. Thus, containment is not considered as necessary. The safety basis developed will determine the requirements for additional confinement of the reactor to meet defense in depth principles for public health and safety. While some designs call for strong, hardened structural buildings with filtered venting, this issue will require NRC review and approval. Filters for remobilized radioactive dust during LOCA should be developed to reduce potential releases even more.
- i. Instrumentation and Control—The proposed designs will use state-of-the-art computerized instrumentation and control. This technology will need to be thoroughly reviewed by the NRC relative to maintaining the safety function. Although the pebble bed is significantly different than an LWR in terms of response times, it is expected that NRC will have a keen interest in the instrumentation and control.
- j. Core Neutronics—Since the pebble bed has an online refueling system and the location of the fuel cannot be precisely known, core performance models will need to be developed and verified by tests of the pebble flow. Presently, the code used for this analysis is called VSOP. This code has a long history in Germany and has been the accepted baseline code for core performance for pebble bed reactors. The VSOP code needs to be verified and validated for United States application. MIT presently has an effort underway to perform such a verification and validation. INEEL is developing an alternative, more modern suite of codes that can handle the online refueling system of the pebble bed, but this will take some time and cooperation with other nations.
- k. Verification of Burn-up of the Pebbles—At present, MIT and the University of Cincinnati are developing a burn-up meter to measure the burn-up of the pebbles. Burn-up is a key indicator of safety because the performance of the fuel at high fluence will be degraded and there will be burn-up limits established for the fuels to ensure that the response of the plant during postulated accidents will be limited. At high burn-ups, German data indicates that the fission products will be gradually released if the present fuel reaches temperatures in excess of 1700° to 1800°C for an extended period of time. The design objective will be to have an accurate burn-up measurement,

limit the maximum temperature during the transient, and discharge fuel at certain allowable burn-up levels to keep the plant within the design basis. The objective of the plant design is not to require any offsite emergency response by using only natural systems of heat removal.

- l. Graphite—The long-term behavior of graphite will need to be analyzed relative to radiation effects. The current pebble bed design uses graphite as a permanent, non-exchangeable reflector although consideration is being given to possible replacements. This issue is the lifetime of the graphite to avoid replacement during the 40-year operating life. The present limit is about 10^{26} n/m² for the relevant temperatures (~750°C) at the most exposed areas of the side reflector. Suitable graphite grades have to be qualified by irradiation tests. The modeling of the material still has to be improved to predict the behavior under irradiation and temperature. Innovative fiber reinforced ceramics as discussed for fusion reactor walls should be investigated.
- m. Boron Carbide Depletion—Boron carbide absorbers are included in the design to limit the streaming effects of the neutrons and to minimize dose in certain areas. There is also a question as to the depletion rate of boron carbide, and this will need to be understood to assess the habitability and possible environmental qualification of certain instrumentation and structures.
- n. Worker Exposure—The pebble bed reactor has an online refueling system and, depending upon the design, will likely require maintenance during operation. The repair and maintenance of this system will require review. The helium coolant is inert and generates very small amounts of LLW, thus reducing worker exposure. The microsphere fuel does allow the diffusion of silver 110m, which will plate out on cooler surfaces in the plant. For an IHX system, this should not be a maintenance concern but will require additional attention for direct cycle systems. MIT is researching how to retard silver migration and will be looking at alternative fuel cycles in addition to the on-line system being proposed.
- o. Defueling System—Over the long-term operation of the plant, some complete defueling of the reactor either for inspections or maintenance might be required. The design of the defueling system would generate NRC interest. This area would also include extrinsic proliferation control systems to assure that any diversion of fuel is detected. MIT has a study underway to assess the proliferation resistance of the pebble bed reactor.
- p. Decommissioning and Spent Fuel Storage—NRC will be interested in the decommissioning and spent fuel storage plan for this facility. At present all spent fuel is expected to be stored in the basement of the plant for the life of the facility and beyond. Present experience at the AVR will be applicable to the development of a decommissioning plan.

A-5 Technical Innovations (Potential Design Improvements)

A-5.1 Fuel Quality

Since the safety basis of pebble bed reactors largely rests on the quality of the fuel, this will require extensive review, analysis, and a demonstration of high quality manufacture. At present, there are two manufacturers of microsphere fuel. One is in Japan at the Nuclear Fuel Industries (NFI) plant in Oarai, and the other is in China at the Institute of Nuclear Energy Technology. It should be noted that the actual fuel has not been developed for inherent safe modular reactors—as they were not yet been invented at that time, but has for large-sized HTRs with active safety systems and burn-up targets in the range of 80,000 MWd/t. An optimization of the fuel for higher burn-up and higher temperature resistance has not yet taken place. Thus, there is still a huge innovation potential for HTR fuel being designed for the

requirements of Generation IV reactors. Any progress in this direction will allow increasing the power capability of modular HTR and their economics, respectively.

Detailed modeling of the fuel and its behavior can be the first step towards an improved coated particle design with novel kernel compositions (e.g., for Plutonium burning or ultrahigh burnup). Such particles have to be produced and tested under irradiation to verify the models and improve the fabrication processes. MIT is now developing a detailed microsphere fuel performance model.

The development of highly automated HTR fuel fabrication and the related quality control procedures is another target with direct impact on the economics and quality of the fuel. The development of methods permitting fully remote fabrication would be valuable as greatly increasing the flexibility and proliferation resistance of fuel cycles with processing and recycle. Such R&D programs have been started in the European HTR Technology Network. Irradiation under ultrahigh burnup conditions with subsequent test of the fission product retention capabilities is underway. Fabrication facilities for improved fuel are being built or already in operation at NFI.

The resistance of the fuel against corrosive attack can also be improved by special coatings. First, promising tests have been done. Such coatings can also possibly improve the excellent leaching resistance for direct disposal, thus offering an additional motivation for such a development.

A-5.2 Pressure Vessel Design

The largest single component in the design is the reactor pressure vessel (about the size of an 1,100 Mwe boiling water reactor). The large size limits the modularity potential of the plant. Germany has proposed the use of a PCIV composed of machined cast iron blocks that can be assembled and pre-stressed by axial and circumferential tendons. The PCIV offers advantages in transportation (no large diameter components) and in decommissioning (disassembly instead of cutting techniques, recycling of material for nuclear use).

The PCIV can also be combined with an internal, replaceable and inspectable cooling system for passive decay heat removal (e.g., by using heat pipes within the cast iron structure instead of surface reactor cavity or vessel coolers). This could significantly improve the heat dissipation process and prevent the vessel from overheating in a core heat-up accident. In consequence, there is a further potential for power increase for all types of HTR or other modular or integrated reactors.

In addition, reactor pressure vessel failure, even though an extremely unlikely event (10^{-8} to 10^{-9}), can be effectively eliminated. This is due to the fact that there is (1) a highly redundant multi-filament pre-stressing system and (2) a functional separation of leak-tightness via liner and load absorption by the PCIV structure. In case of over-pressure, the vessel releases the pressure inherently and closes the openings again when the pressure comes down. This feature has already been confirmed by extensive tests. More research and development is required to develop these concepts.

A-6 Statement of Overall Concept Potential Versus R&D Risk

The overall evaluation of the PBR concept is that it should be included in the Generation IV evaluation process as a viable candidate for demonstration and deployment. Notwithstanding the South African and Exelon efforts for near term deployment, this technology has a place for future electric generation, cogeneration, and various process heat applications, thus meeting most if not all Generation IV goals. The biggest shortcoming appears in one area—sustainability of a fuel supply for the long term since it is a thermal reactor. Should the thorium fuel cycle be developed for this technology, as appears very promising; this concern can be greatly alleviated for a long period. This technology will be a

mid-term transition technology to a more sustainable, fast spectrum technology perhaps based on fast spectrum gas reactors that offer great promise. The power conversion technology developed in the pebble bed systems can be directly applied to fast gas systems that yield higher fuel efficiencies due to the higher conversion ratios.

A-6.1 Specific Evaluations of Other Pebble Bed Reactor Concepts

- G4 – ACACIA—This technology is not intended for large-scale power production and does not strictly meet the requirements of Generation IV. It has the same inherent safety features of all pebble beds and the OTTO with *peu-a-peu* cycle provides additional advantages in reducing the cost of the on-line refueling system. At present, should pebble bed reactors be developed and should the need for small industrial electrical and heat applications be required, this smaller version of the fundamental pebble bed reactor could prove attractive. It must, however, follow the wide-scale introduction of larger pebble bed reactors to help improve the economics of the ACACIA plant.

Recommendation: ACACIA be dropped from further consideration due to its small size.

- G6 – SGR—There was not much technical information provided for this concept except that it was a small 5 MWe steam cycle plant with some interesting concepts of modularity and transportability. It also suggested some internet-based monitoring and control system for these plants. It was not clear whether they were online refueling or OTTO pebble plants.

Recommendation: While this concept proposed some interesting ideas that might be applied to the larger version of the pebble bed, it is recommended that this concept be dropped from further consideration due to its small size and lack of definition.

- G15 – Reconfigurable Deterministically-Fueled Pebble Bed Modular Reactor—This concept has the same safety advantages of the reference design but introduces a new complexity in pebble motion in the core. While on the surface it appears desirable to make a pebble bed more deterministically predictable in terms of core neutronics, the issue is whether this “advantage” is worth the additional complexity in internal, structural core design. The advantage of the open core pebble bed is elimination of the need to replace the inner reflector, periodically.

Recommendation: This concept should be considered as a research variation to the reference concept.

- G17 – Annular Pebble Bed Reactor—It appears that the innovation in this design over the reference pebble bed reactor is the use of a PCIV that cannot show sudden burst and has an integrated decay heat removal system. This type of vessel can be used for other reactor systems, as well. The other main difference is a central graphite column to realize an annular core with enhanced power, as compared to the PBMR and PBR.

Recommendation: It is not evident that there is a need to further reduce the risk of reactor pressure vessel failure in beyond design accidents. However, the possible increased power capability and ease of shipment of this type of reactor vessel is worth exploring. For example, should such cast iron transportable blocks be cheaper to manufacture, ship to the site, and assemble than a conventional pressure vessel, this concept should be retained for evaluation for application in the generic concept. Additional benefits are expected for decommissioning as the cast iron blocks can be easily disassembled after removing the tendons. It is also recommended to investigate the integration of the passive cooling system into the PCIV as it may enhance the heat removal capabilities and allow for larger power sizes and improved economics. The central









column in the core can also help to increase the power of pebble bed systems and provides some more deterministic boundary conditions for the pebble flow as compared to the dynamic central area of the PBMR core design. Progress in graphite irradiation resistance is a pre-requisite for this innovation. Therefore, this concept (G17) is considered to be an R&D variation of the reference concept.







Screening for Potential Scoresheet

Concept Name: PBR Summary: X Retain, Reject
 Comparison to Reference: Much Worse Worse Similar Better Much Better
 Comments

Sustainability 1				
SU1-1: Fuel utilization				The PBMR is more efficient than the ALWR, resulting in less fuel consumption per kwh. Also, improvements are possible in improve burnups, providing an overall 1.5 to 2.0 improvement in fuel efficiency. In addition, pebble bed reactors can use U/Th/Pu fuel cycles and combined heat and power applications.
SU1-2: Fuel cycle impact				The areal power density of the PBMR is about 10 kw/ft2. This is about a factor of two larger than the AP-1000. The PBMR would have lower thermal discharge, therefore lower land use for cooling towers, ponds, or canals. PBMR would also have lower LLW and HLW waste generation. A smaller EPZ confined to the site boundary.
SU1-3: Use of other resources				Helium is a needed resource for the PBMR but this gas is not inherently scarce (a byproduct of natural gas recovery). The government may consider capturing He that is now vented to the atmosphere. There are no scarce materials used in PBMR.
Sustainability 2				
SU2-1: Waste minimization				<p>The SNF/HLW burden can be estimated by Ci, volume, or mass. In terms of fuel volume, the PBMR has ten times that of AP 600 for a given energy production. But, PBMR fuel may be directly disposable, thereby reducing the overall waste package volume compared to the AP 600. In addition the space taken in a repository per kwhr generated is less de to higher efficiency and lower heat rate per package. Curies are lower for PBMR because of the higher thermal efficiency of the reactor. Similarly, the mass of heavy metal would be lower for PBMR because of the higher thermal efficiency and the higher initial enrichment.</p> <p>The overall actinide burden would be lower for the PBMR because of the higher burnups experienced.</p> <p>Because the overall volume used within the repository should be driven by the heat generated by the waste form, PBMR should have a distinct advantage versus AP600. Also, the leachability of fission products from the pebble fuel is much lower than for the LWR and as good as vitrified HLW.</p>

SU2-2: Environmental impact					Direct disposal of spent fuel. No reprocessing impacts. Low leach rate fuel in water. Higher thermal efficiency smaller impacts and helium is a cleaner coolant for easier decommissioning.
SU2-3: Stewardship burden					Unique characteristics--a very stable fuel form, all ceramic containment with graphite overcoating allowing very non-leachable storage for long time reducing stewardship concern for geological storage.
Sustainability 3					
SU3-1: Material life cycle Vulnerability					Vulnerability is low because the fuel form is very difficult to reprocess, the fuel is used to high burnup, and there is a very low fissile content per pebble (less than 1 gram). This translates into diversion of 800,000 pebbles for 8 kg of Pu which can be detected using conventional IAEA safeguards.
SU3-2: Application of extrinsic Safeguards					On-line loading of fuel enables intentional mismanagement, but the small number of access paths and the large number of pebbles needed to obtain quantities of concern enables monitoring and control. Traditional IAEA safeguards to detect diversion readily available.
SU3-3: Unique characteristics					A very large number of balls are needed. Buildup and release of C-14, if reprocessed. SiC very hard material complicating reprocessing.
Safety and Reliability 1					
SR1-1: Reliability					Plant is simple in design, no ECCS, CVCS, hydrogen igniters, containment spray systems, etc. This means less parts to fail and need to be in compliance with Technical Specifications for operation. Design of PBR has a replacement versus repair strategy due to modularity – shorter outages or even replacements of modules on line. The AP 600 has an 18 month refueling cycle (CF ~ 85-90%) while the PBMR
SR1-2: Public/worker-routine exp.					The PBMR is better because there are no activation products (crud, magnetite, etc.) circulating in the coolant as with a PWR. Overall, workers are expected to have at least a factor of ten reduction (man-rem per year versus hundred man-rem per year) compared to the AP 600.
SR1-3: Worker safety-accidents					The AP600 has activation products and high energy steam which have greater consequences for worker safety in accident conditions. In addition, the radioactive contamination of the helium system is significantly less.

Safety and Reliability 2					
SR2-1: Robust Safety Features					Plant is deterministically safe not requiring engineered safety features. Safety features are part of the fuel and core design. Tests in Germany support these findings. Cores can not melt. Air ingress limited. Containment provided by silicon carbide microspheres.
SR2-2: System model uncertainty					Deterministic core behavior during accidents minimizes uncertainty for the PBMR. The actual core can be shown to meet maximum design basis accident without fuel failure. Core behavior easy to characterize. Margins to core melting in excess of 2000°C. Bounding analyses possible.
SR2-3: Unique characteristics					No mechanical systems are needed to prevent core meltdown. Decay heat removal is totally passive, with low likelihood attaining temperatures which damage fuel. Reactivity control: There is very low surplus reactivity and no water ingress is possible (for indirect gas turbine cycle). Time constants are very long due to the high thermal inertia of the core.
Safety and Reliability 3					
SR3-1: Robust mitigation features					Low Power density and SiC coated fuel particles with low U loading—does not reach fuel melting temperatures. SiC coated particles provide containment function. Confinements provided. Air ingress theoretically could cause some release of fission products but not sufficient to violate EPZ boundary does requirements.
SR3-2: Damage/dose understood					There is a potential for carbon dust to carry air contamination in an accident. Source term, transport, and dose are similarly understood to those of an ALWR. Improvements remain to be made in understanding and achieving high quality manufacture of PBMR/TRISO fuel. Predicting behavior of ceramic coatings under accident conditions still requires work to full understand their behavior.
SR3-3: No additional indiv. risk					
SR3-4: Comparable societal risk					
Economics 1					
Life Cycle Cost Advantage					
EC-1: Low capital costs					ESKOM estimates \$ 1,000/kW based on bids received for construction. MIT conservative estimate \$ 2,000/kW with no bid information. US target \$ 1,200/kW

EC-2: Low financial costs				PBMR takes less time to build resulting in less financial exposure and risk.
EC-3: Low production costs				Operating cost should be lower--operating staff estimated to be less than 1/2 that for AP 600.
EC-4: Low development costs				Relative to the AP-600, since ESKOM is planning to build one in the next several years development costs must be less.
EC-5: High profitability				PBMR can make other products--the thermal discharge temperature is sufficient for bottoming cycles such as desalination. The core exit temperature is sufficient to consider many process heat applications especially plants with intermediate heat exchangers to increase profitability. Profitability is based on market prices so this is hard to estimate.
EC-6: Cost of Power				Bus bar costs are estimated by ESKOM to be 1.8 cents/kWhr, Exelon estimates approximately 3.0 cents/kWhrs. MIT numbers are 3.3 c/kWhr.
Economics 2 Low Financial Risk				The time to build a PBR module is estimated to be about 2.5 years. This greatly reduces the time of financial exposure as well. Factory fabrication of modules also reduces risk since the quality can be better assured.

APPENDIX B

Prismatic Fuel Modular Reactor (PMR) Systems Summary Report

CONTENTS

ACRONYMS.....	59
B-1. GENERAL DESCRIPTION	63
B-2 POTENTIAL OF THE CONCEPT FOR MEETING THE GENERATION IV GOALS.....	65
B-2.1 Sustainability.....	65
B-2.1.1 Sustainability 1: Effective Resource Utilization	65
B-2.1.2 Sustainability 2: Waste Management.....	67
B-2.1.3 Sustainability 3: Proliferation Resistance and Safeguards.....	68
B-2.2 Safety and Reliability	69
B-2.2.1 Safety and Reliability 1	69
B-2.2.2 Safety and Reliability 2.....	71
B-2.2.3 Safety and Reliability 3.....	71
B-2.3 Economic Competitiveness	72
B-2.3.1 Economics 1.....	73
B-2.3.2 Economics 2.....	73
B-3 RESEARCH AND DEVELOPMENT	74
B-3.1 Brief Summary of Progress to Date	74
B-3.2 Description of the Research and Development Underway or Planned	75

FIGURES

B-1. GT-MHR Power System	63
B-2. Core Heat-up Temperatures with Passive Heat Rejection.....	70

Tables

B-1. GT-MHR Nominal Full Power Operating Parameters.....	64
--	----

ACRONYMS

ALWR	Advanced Light Water Reactor
BDBA	Beyond Design Basis Accident
EAB	Exclusion Area Boundary
EC	economic competitiveness
FA	fuel assembly
FHS	Fuel Handling System
GT-MHR	Gas Turbine – Modular Helium Reactor
HLW	high-level waste
LEU	low enriched uranium
LLW	low-level waste
LWR	light water reactor
MHR	modular helium reactor
O&M	operation and maintenance
OKBM	Experimental Machine Building Bureau
PBMR	Pebble Bed Modular Reactor
PMR	Prismatic-Core Modular Thermal Reactor
R&D	research and development
RCCS	reactor cavity cooling system
RF	Russia Federation
RTW-MHR	Reactor Transmutation of Waste Concept using the Module Helium Reactor
SHE	Shutdown Heat Exchanger
SR	safety and reliability
SU	sustainability
TRU	transuranic (waste)
WPu	weapons plutonium

Appendix B

Prismatic-Core Modular Thermal Reactor (PMR) Systems Summary Report

B-1. General Description

The Gas Turbine – Modular Helium Reactor (GT-MHR) was selected by the Gas-Cooled Reactor Technical Working Group to be the representative or lead concept of the prismatic-core modular thermal reactor (PMR) concept set. General Atomics Co. of La Jolla, California, submitted all five PMR concepts. Three variants used low enriched uranium (LEU) fuel cycles but different power conversion systems. Two other variants used differing fuel cycles. These concept variations illustrate the inherent application and fuel cycle flexibility of PMRs. The GT-MHR nuclear power system has passive (natural) safety features, high thermal efficiency, environmental advantages, and competitive electricity generation costs. The GT-MHR module couples the reactor, contained in one vessel, with a high-efficiency Brayton cycle, gas-turbine energy conversion system contained in an adjacent vessel. The reactor and power conversion vessels are interconnected with a short cross-vessel and are located in a below-grade concrete silo, as shown in Figure B-1.

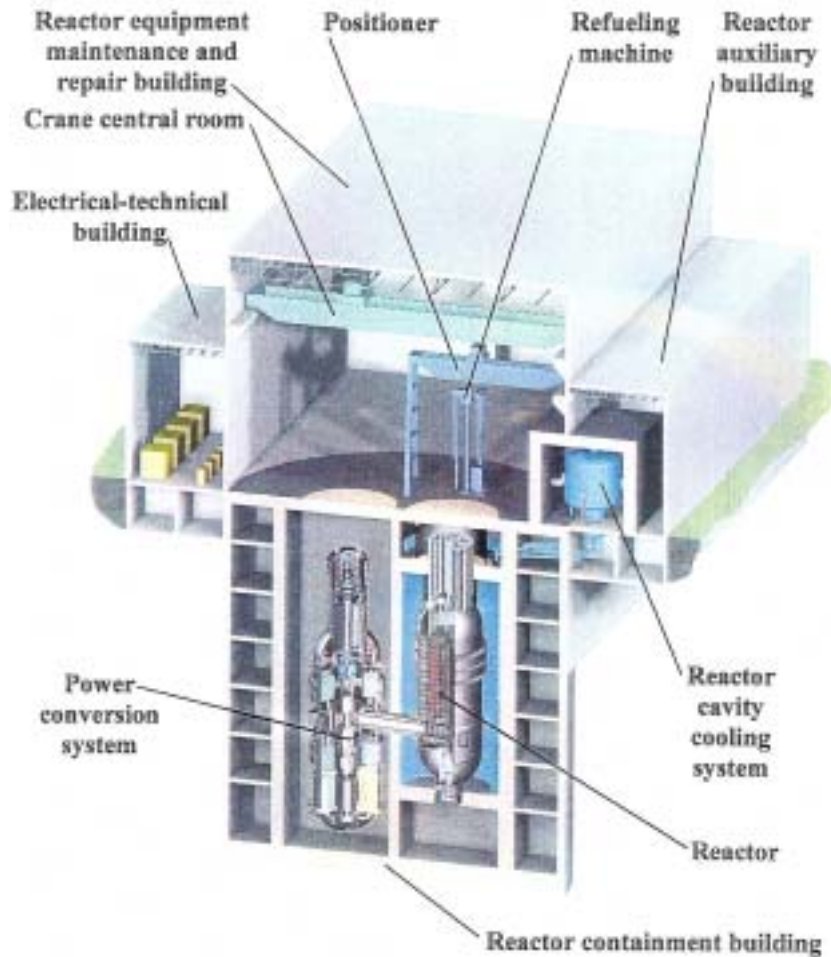

Figure B-1. GT-MHR power system.

Helium coolant is heated in the reactor by flowing through coolant channels in graphite fuel elements. The heated coolant flows through the cross-vessel to the power conversion system. In the power conversion system, a gas turbine, electric generator, and gas compressors are located on a single, vertically orientated shaft supported by magnetic bearings. Heated helium from the reactor is expanded through the gas turbine to generate electricity. From the turbine exhaust, the helium flows through the hot side of a recuperator transferring residual heat energy to helium on the recuperator cold side returning to the reactor. From the recuperator, the helium flows through a pre-cooler, then passes through low and high-pressure compressors with intercooling. From the compressor outlet, the helium flows through the cold, high-pressure side of the recuperator where it is heated for return to the reactor. Nominal full power operating parameters are given in Table B-1.

Table B-1. GT-MHR Nominal Full Power Operating Parameters

Reactor Power, MWt	600
Core Inlet/Outlet Temperatures, °C	491/850
Core Inlet/Outlet Pressures, MPa	7.07/7.02
Helium Mass Flow Rate, Kg/s	320
Turbine Inlet/Outlet Temperatures, °C	848/511
Turbine Inlet/Outlet Pressures, MPa	7.01/2.64
Recuperator Hot Side Inlet/Outlet Temps, °C	511/125
Recuperator Cold Side Inlet/Outlet Temps, °C	105/491
Net Electrical Output, MWe	286
Net Plant Efficiency, %	48

The gas-turbine power conversion system has been made possible by key technology developments during the past decade, primarily in efficient large aircraft and industrial gas turbines; large active magnetic bearings; and compact, highly effective gas-to-gas heat exchangers. Recent gains in reactor technology are in areas of high-strength, high-temperature steel alloy vessels and in-vessel metallic structures, and carbon-carbon control rod housings.

Key design characteristics of the Modular Helium Reactor (MHR) are the use of helium coolant, graphite moderator, and refractory coated particle fuel. The helium coolant is inert and remains single phase under all conditions; the graphite moderator has high strength and stability to high temperatures; and the refractory coated particle fuel retains fission products to high temperatures.

The refractory coated particle fuel, identified as TRISO-coated particle fuel, consists of a spherical kernel of fissile or fertile material, as appropriate for the application, encapsulated in multiple coating layers. The multiple coating layers form a miniature, highly corrosion resistant pressure vessel and an essentially impermeable barrier to the release of gaseous and metallic fission products. The SiC coating prevents diffusion of gaseous radionuclides at temperatures below 1600°C, and does not start to thermally degrade until temperatures reach the 1600-1800°C range. The core and vessel systems are designed such

that normal operating temperatures do not exceed about 1250°C and worst-case peak temperatures during accidents stay below 1600°C.

The overall diameter of standard TRISO-coated particles varies from about 650 microns to about 850 microns, depending on particle design. For the GT-MHR, TRISO-coated particles are mixed with a matrix material and formed into cylindrical fuel compacts approximately 13 mm in diameter and 51 mm long. The fuel compacts are loaded into fuel channels in hexagonal graphite fuel elements, 793 mm long by 360 mm across flats. One hundred and two columns of the hexagonal fuel elements are stacked 10 elements high to form an annular core. Reflector graphite blocks are provided inside and outside of the active core. As mentioned earlier, the operating characteristics of the gas-cooled reactors accommodate use of a wide range of fuel cycles without changing the basic reactor system design—the changes are primarily in the core design and control features. For example, the Reactor Transmutation of Waste concept using the Modular Helium Reactor (RTW-MHR) provides means for destroying the transuranic (TRU) waste from existing and future reactors while extracting the maximum useful electrical energy from the waste. The RTW-MHR concept utilizes the same basic design as the GT-MHR. The design is identical in layout, dimensions, power level, and overall operating conditions to the GT-MHR, but it uses TRU waste consisting of plutonium and minor actinides as the fuel. Because of the graphite moderator and helium coolant, the RTW-MHR concept has a relatively hard thermal neutron spectrum and a low parasitic neutron capture rate. Thus, it can utilize a full core of non-fertile fuel to destroy large quantities of TRU waste.

In this reactor option, it is assumed that TRU waste will be reprocessed to recover the uranium at high purity levels for reuse or disposal as Class C waste. The fission products are also extracted, and the TRU consisting of the neptunium, plutonium, americium, and curium isotopes that were produced during the previous critical reactor operation are fissioned in the GT-MHR core. The waste discharged from the GT-MHR after irradiation contains almost no plutonium; hence, it is no longer a proliferation risk. The waste is then reprocessed into new coated particles and graphite elements identical to those used in the driver region. These elements are loaded into separate fuel rods in the core, where over 50% of the remaining minor actinides are transmuted and destroyed. The discharged graphite elements are extremely stable and resistant to corrosion, and they can be placed directly in a repository. Long-term corrosion models developed from tests conducted at the Oak Ridge National Laboratory and Hanford predict only a 10^{-4} coated particle failure fraction after 10^6 years in a repository.

B-2 Potential of the Concept for Meeting the Generation IV Goals

The GT-MHR design is judged to support Generation IV goals within the areas of sustainability (SU), safety and reliability (SR), and economics (EC). The greatest advance toward Generation IV goals is in the area of safety and reliability as a result of natural safety characteristics.

B-2.1 Sustainability

B-2.1.1 Sustainability 1: Effective Resource Utilization.

The GT-MHR makes efficient use of nuclear fuel resources because of its high thermal conversion efficiency and because high fuel burnup is made possible by the use of TRISO-coated particle fuel. Additionally, the GT-MHR is readily adaptable to the utilization of a variety of nuclear fuels. A prime example is work presently in progress for the use of the GT-MHR for the disposition of weapons plutonium (WPu). For this application, the GT-MHR provides the capability to consume more than 90% of the initially charged Pu-239 and more than 65% of the initially charged total plutonium in a single pass through the reactor. This level of plutonium destruction is well beyond that achievable by the Advanced Light Water Reactor (ALWR). By achieving this high level of plutonium destruction, the GT-MHR

extracts a substantially higher portion of the useful energy content from the material than would be possible with the ALWR without reprocessing or recycling. Because the plutonium fueled GT-MHR uses no fertile fuel material, all fissions are plutonium fissions, and no new plutonium is produced. Comparable results would apply to the utilization of reactor grade plutonium.

Early applications of PMR technology employed by the GT-MHR focused on thorium-uranium (Th-U) fuel cycles. These cycles were initially abandoned due to proliferation concerns (incorporation of thorium fertile particles produced separable U-233 and required high-enriched uranium fissile particles). For the Th-U cycles, coated particles containing thorium are included in the active core for the production of U-233 with options for subsequent recycle. These fuel cycles are projected to be very economical and to make very efficient use of the thorium resource. For the deployment of either U-Pu or Th-U fuel cycles involving the use of recycle material, the development of coated particle spent fuel reprocessing technology would require completion, and proliferation concerns associated with nuclear fuel reprocessing and recycle would require resolution.

With regard to the use of land resources, the passive safety characteristics of the GT-MHR would result in no requirement for emergency planning for evacuations outside a small exclusion area zone around the reactor plant. As a consequence, the GT-MHR would need much less land space than a comparably-sized light water reactor (LWR), and close-in siting of plants to points of energy use is possible. Close-in siting of energy generation plants reduces both land and electricity distribution resource requirements and makes other process heat applications more attractive.

The thermal discharge (waste heat) from the GT-MHR is one-half that for LWRs per unit of electricity produced (assuming 32% ALWR efficiency vs. 48 % GT-MHR efficiency). If this waste heat were to be discharged using conventional power plant water heat rejection systems, the GT-MHR would require one-half as much water coolant per unit of electricity produced. Alternatively, because of this, the GT-MHR waste heat could be rejected directly to the atmosphere using air-cooled heat rejection systems such that no water coolant resources are needed. Because of this capability, the use of the GT-MHR in arid regions is practical.

- SU1-1 – Fuel Utilization [++]. The reference GT-MHR fuel cycle utilizes LEU (<19.9% enriched, with an average enrichment of ~10%), but PMR cores have been designed to utilize a broad spectrum of fissile and fertile materials including LEU/Th, Pu/U, Pu/Th, high enriched uranium (HEU), and WPu. The relatively hard thermal neutron spectrum produced by graphite moderation and neutronically transparent helium coolant permits burnups of ~120,000 MWd/t with LEU fuel without recycle. Because of its higher efficiency, the GT-MHR utilizes less fuel and, thus, produces less waste per MWh.
- SU1-2 – Impact on Environment [++]. By eliminating LWR TRU waste and generating useful electrical energy at the same time, this system can help develop public acceptance of nuclear power. By 2015 it is estimated that there will be over 700 tons of LWR TRU waste in the United States alone. At 600MW(t), operation of the GT-MHR Reactor-Based Transmuter consumes 0.2MT of TRU per year; thus, there is sufficient fuel for long-term operation of many units of this reactor type. Because of its higher efficiency, the discharge of waste heat from a GT-MHR is typically about half that of LWRs.
- SU1-3 – Utilization of Other Resources [++]. As in the case of the Pebble Bed Reactor concepts, the helium and graphite needed for the GT-MHR are not in short supply, and there are no known scarce materials.

B-2.1.2 Sustainability 2: Waste Management.

The GT-MHR produces less heavy metal radioactive waste than the ALWR and may be a superior fuel form for disposal in a geologic repository. The GT-MHR characteristics that result in fewer heavy metal radionuclides are the plant's high thermal efficiency and high fuel burnup. The refractory fuel coatings provide barriers for containment of radionuclides in a repository environment.

Because of its high efficiency, harder neutron spectrum, and high fuel burnup, the GT-MHR produces less heavy metal radioactive waste than conventional nuclear power plants per unit of electricity produced. It is estimated that LWRs produce 150% more actinides (heavy metal radionuclides) than the GT-MHR per unit of electricity production.

For both long-term storage and permanent disposal in a repository, the TRISO fuel particle coating system, which provides containment of fission products under reactor operating conditions, also provides an excellent barrier for containment of the radionuclides for storage and geologic disposal of spent fuel. Experimental studies have shown the corrosion rates of the TRISO coatings are very low under both dry and wet conditions. The coatings provide a multiple-barrier, waste management system. The measured corrosion rates indicate the TRISO coating system should maintain its integrity for a million years or more in a geologic repository environment.

The system destroys TRU waste while producing useful power and can reduce the permanent repository burden by almost two orders of magnitude. Spent PMR fuel elements may be a final waste form, which require no further processing or additional barriers (e.g., overpack). In comparison, a large fraction of LWR spent fuel disposed in a geologic repository as whole elements in a once through fuel cycle would become exposed within several hundred to several thousand years because of the expected failure of the metallic fuel cladding and the corrosion of metallic fuel element canisters. The only barriers for release to the accessible environment would be repository backfill materials and the surrounding geologic media.

- ***SU2-1 – Waste Minimization [+]***. High thermal efficiency and other characteristics that contribute to the generation of fewer heavy metal radionuclides result in reduced high-level waste (HLW) on a per unit electric generation basis. Experience with PMR operations has shown that the low-level waste (LLW) discharges are small.
 1. ***Mass and Volume of HLW/SNF Sent to Repository [+]***. Fuel volumes per MWh(t) would be larger than that for ALWRs due to the lower power density, but there would be a reduction in this factor for comparisons per MWh(e) due to the higher thermal efficiency of the GT-MHR. The GT-MHR fuel is directly disposable either in the graphite block fuel assembly (FA) or in the compacts (removed from the FA). Spent GT-MHR fuel may be a final waste form that requires no further processing or additional barriers.
 2. ***Decay Heat Thermal Output [+]***. The overall decay heat burden per MWh [e] would be less than that for the ALWR due to its higher efficiency and lower minor actinide production
 3. ***Activity Measures [+]***. As in the case of the PBMR, the total Curie loads of the HLW are lower due to the higher thermal efficiency and the higher initial enrichment. The overall actinide burden is lower due to the higher burnup and harder spectrum.

- SU2-2 – Environmental Impact [+]. The GT-MHR fuel elements may be suitable for direct disposal due to the high resistance to leaching and corrosion shown by the graphite block FA and the TRISO particle coatings. Again, the higher thermal efficiency leads to a reduction of total waste per MWh (e). Disposal of the FA graphite blocks by burning is not advisable due to the release of Carbon-14.
- SU2-3 – Stewardship Burden [+]. As in the case of the Pebble Bed Modular Reactor (PBMR), the stewardship burden for the GT-MHR is less than that for ALWRs because of its higher thermal efficiency and high integrity of the HLW form.

B-2.1.3 Sustainability 3: Proliferation Resistance and Safeguards.

The GT-MHR has high proliferation resistance and has been designed to satisfy international safeguard requirements. The GT-MHR's high proliferation resistance is primarily due to the refractory coated fuel form and the reactor's characteristically low fissile fuel volume fraction.

Three characteristics of the GT-MHR refractory coated fuel lead to high proliferation resistance:

- The coatings provide a high temperature, high integrity structure for retention of fission products to very high burnups
- The refractory coatings provide a containment from which it is difficult to retrieve fissile materials
- In the waste transmutation fuel cycle mode of operation, the GT-MHR destroys over 90% of the Pu-239 in a single irradiation cycle, thus eliminating proliferation concerns about the waste that is finally sent to the repository.

Both GT-MHR fresh fuel and spent fuel have higher resistance to diversion and proliferation than the fuel for the ALWR. The GT-MHR fresh fuel has high proliferation resistance because the fuel is very diluted by the fuel element graphite (low fuel volume fraction) and because of the technical difficulty to retrieve materials from within the refractory fuel coatings. GT-MHR spent fuel has the self-protecting, proliferation resistance characteristics of other spent fuel (high radiation fields and spent fuel mass and volume). The reasons for the higher proliferation resistance are:

1. The quantity of fissile material (plutonium and uranium) per GT-MHR spent fuel element is low due to the low fuel volume fraction, making diversion of heavy elements difficult.
2. The GT-MHR spent fuel plutonium content, the material of most proliferation concern, is exceedingly low in both quantity per spent fuel block and quality because of the high fuel burnup. The discharged plutonium isotopic mixture is degraded well beyond that of LWR spent fuel, making it particularly unattractive for use in weapons.
3. There is neither a developed process nor capability anywhere in the world for separating the residual fissionable material from GT-MHR spent fuel.

GT-MHR performance in the three Proliferation Resistance and Safeguards sub-areas are as follows:

- SU3-1 – Minimize Material Life Cycle Vulnerability [+]. The reference fuel cycle is LEU (<19.9% enriched, ~10% average). The uranium is never in metallic form, and the fuel has unfavorable isotopics at discharge. The uranium and/or plutonium are very difficult to recover from TRISO-coated fuel particles, and are in a highly dilute fuel form. Controlled, periodic off-line refueling simplifies monitoring.

- SU-3-2 – Facilitate Material Accounting and Application of International Safeguards [+]. Controlled, periodic off-line refueling allows extrinsic safeguards application.
- SU-3-3 – Unique Characteristics [+]. As in the case of the PBMR, a huge volume of spent fuel would need to be diverted to accumulate a critical mass of plutonium.

B-2.2 Safety and Reliability

B-2.2.1 Safety and Reliability 1 [++].

The GT-MHR safety is achieved through a combination of inherent safety characteristics and design selections that take advantage of the passive safety characteristics. These characteristics and design selections include:

1. Helium coolant, which is single phase, inert, and has no reactivity effects
2. Graphite core, which provides high heat capacity, slow thermal response, and structural stability at very high temperatures
3. Refractory coated particle fuel, which retains fission products at temperatures much higher than normal operation and postulated accident conditions
4. Negative temperature coefficient of reactivity, which inherently shuts down the core above normal operating temperatures
5. An annular, low power density core in an uninsulated steel reactor vessel surrounded by a natural circulation reactor cavity cooling system (RCCS).

For passive removal of decay heat, the core power density and the annular core configuration have been designed such that the decay heat can be removed by heat conduction, thermal radiation, and natural convection without exceeding the fuel particle accident temperature design goal. Core decay heat is conducted to the pressure vessel and transferred by radiation and convection from the vessel to the natural circulation RCCS. The RCCS provides an independent passive means for the removal of core decay heat in the event the two active, diverse heat removal systems—the power conversion system and a shutdown cooling system—are not available. Even if the RCCS is assumed to fail, passive heat conduction from the core, thermal radiation and convection from the vessel, and conduction into the silo walls and surrounding earth is sufficient to maintain peak core temperatures to below the design limit (see Figure B-2). In this case, however, vessel damage is likely to occur. Radionuclides are retained with the refractory coated fuel particles without the need for AC powered systems or operator action. These safety characteristics and design features result in a reactor that can withstand loss of coolant circulation or even loss of coolant inventory and maintain fuel temperatures below damage limits.

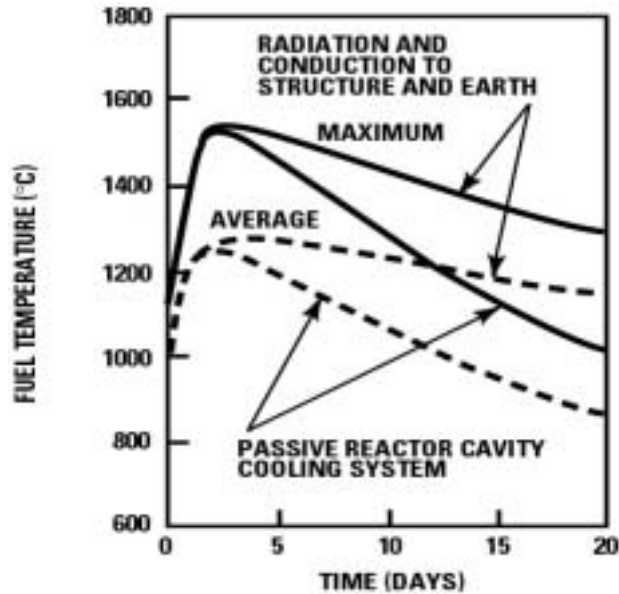

L-103(1)
2-10-94

Figure B-2. Core Heat-up Temperatures with Passive Heat Rejection

The large heat capacity of the graphite core structure is an important inherent characteristic that significantly contributes to maintaining fuel temperatures below damage limits during loss of cooling, or coolant, events. The core graphite heat capacity is sufficiently large to cause any heatup, or cooldown, to take place slowly. A substantial time (on the order of days vs. minutes for LWR reactor types) is available to take corrective actions to mitigate abnormal events and to restore the reactor to normal operations.

All of these passive safety features, combined with the large margin between normal operating and design limit temperatures and the very long response times for accident conditions, significantly reduce the demands on safety system design and operation.

- SR1-1 – Reliability [++]. Once the concept has matured, the reliability of the GT-MHR should be greater than that of the AWLR because of the relative simplicity of the safety and operating systems (a smaller number of systems with less stringent requirements). Fewer and simpler technical specifications would result in a lower forced outage rate. Maintenance and servicing demands for the gas-turbine cycle may be less than for the Rankine cycle.
- SR1-2 – Public and Worker Routine Exposure [++]. PMRs have an excellent record for worker exposure. Typically, maintenance can be done on components without special shielding or contamination. As in the case of PBMR, there is concern for the amount of silver-110m diffusion through intact TRISO particle barriers, which may be a factor in turbine maintenance exposure for direct-cycle plants. Effects of excessive plateout can be mitigated with protective shielding devices.
- SR1-3 – Worker Safety – Accidents [++]. The absence of high-temperature, high-pressure steam reduces the risk compared with LWR plants. The lower circulating activity in the GT-MHR and the relative absence of contaminated water systems in the BOP reduces the chances of exposure during accident scenarios.

B-2.2.2 Safety and Reliability 2 [++].

Coated particle fuel and a ceramic core can operate well with peak temperatures of ~1250°C without structural damage since the module is designed to passively maintain fuel temperatures below a design goal level of 1600°C for all events with probabilities of $>5 \times 10^{-7}/\text{yr}$. Peak fuel temperatures do not occur for several days after loss of coolant because of the low core power density and the large heat capacity of the graphite core components. The helium coolant is neutronically inert and is not subject to any phase changes. Strongly negative temperature coefficient of reactivity from ambient temperature to bounding accident temperatures, coupled with very large core temperature safety margins, provides passive response even to anticipated transients without scram. The reactor system design (e.g., ceramic materials, annular geometry, etc.) facilitates rapid recovery and restart, even after postulated simultaneous loss of coolant and loss of flow.

- SR2-1 – Robust Engineered Safety Features [+]. The need for engineered safety features is minimized due to the inherent safety characteristics of the GT-MHR, and the less stringent requirements due to large safety margins and slow accident response times.
- SR2-2 – System Models Have Small and Well-Characterized Uncertainty [++]. Analyses of PMRs are simpler than those of LWRs because of the single-phase (helium) coolant, the slow response, and the integrity of the core geometry. Large margins between the peak operating and safety limit temperatures reduce the need for highly accurate predictions.
- SR2-3 – Unique Characteristics [++]. PMRs have many inherent unique safety characteristics, as listed in Section B-2.2. The Brayton cycle version essentially eliminates concerns of water ingress, and the GT-MHR design eliminates the possibility of rod ejection accidents.

B-2.2.3 Safety and Reliability 3 [++].

The GT-MHR is designed to meet Environmental Protection Agency Protection Action Guides at 425-m Exclusion Area Boundary (EAB) for all events with frequency of $>5 \times 10^{-7}/\text{year}$ (i.e., LPZ located at the EAB).

- SR3-1 – Highly Robust Mitigation Features/Fission Product Barriers [++]. By design, maximum fuel temperatures are projected to be less than the design goal of 1600°C for all design basis accidents and most beyond design basis accidents (BDBAs). The SiC-coated TRISO particles provide the primary containment function. Air ingress accident damage would be minimized due to limited access to air, lack of a “chimney configuration,” high core flow resistance, and the high resistance of reactor-grade graphite to oxidation.
- SR3-2 – Damage, Transport, Site Boundary Dose Understood [++]. The ceramic core configuration is unaffected in accidents; relatively few (vs. LWRs) would be released in case of TRISO fuel failure. The very long times (days) for onset of fuel failure in BDBAs allow for considerable decay of the source term fission products. Confinement response is straightforward compared to sealed containment (failure) response.
- SR3-3 – Societal Risk Comparable to Competing Technology. (Not requested)

B-2.3 Economic Competitiveness

The GT-MHR is projected to be economically competitive with alternative electricity generation technologies. The economic competitiveness of the GT-MHR is a consequence of:

1. The high operating temperature of the MHR
2. The use of the Brayton cycle power conversion system
3. Enhanced safety characteristics
4. A fuel system highly compatible with automated production processes
5. The use of a modest module power size and modular design features allowing for a factory fabrication with significant learning cost reductions
6. Small plant footprint, even for a modular plant
7. High fuel burnup (>100,000 MWd/MT)
8. Low operation and maintenance (O&M) requirements.

The high operating temperature of the MHR coupled with the use of the direct Brayton cycle power conversion system results in high thermal conversion efficiency. The GT-MHR achieves a net thermal conversion efficiency of approximately 48% as compared to current LWR nuclear plants, which have efficiencies of about 32%. This is a 50% improvement in thermal efficiency, which means the GT-MHR produces 50% more electricity than a comparable LWR having the same thermal power.

The enhanced safety characteristics result in reduced needs for safety systems and their associated capital and O&M costs. Reduced equipment and systems result in reduced contributions to plant unavailability. The net effect of reduced power conversion equipment and fewer safety-related systems is reduced overnight construction costs, construction times, and O&M costs and increased reliability, availability, and capacity factors.

Power reactor uranium fuel cost is only a fraction of that of fossil fuels and is significantly less susceptible to real cost escalation because a high proportion of the fuel cost consists of fuel fabrication costs. Only the uranium portion of the fuel cost is susceptible to real escalation like fossil fuels. The fabrication of the GT-MHR coated particle fuel involves processes that can be highly automated. The resultant GT-MHR fuel costs are projected to be higher but comparable with LWR fuel.

The GT-MHR has been designed to take advantage of the economies of modularization and factory fabrication. The GT-MHR uses modularized equipment to the maximum extent possible, and the modules are standardized to maximize cost reductions due to learning in the construction of replicate units. Economic evaluations of the GT-MHR in comparison to similarly sized alternative generation technologies indicate the GT-MHR to be more economical, in terms of cost of electricity generation, to both advanced light water reactor plants and fossil-fired steam power plants, and to be competitive with gas-turbine, combined cycle plants.

Flexibility of application is another important major feature of the MHR that makes its development and deployment economically attractive. The high temperature characteristics of the MHR make possible a wide variety of applications for use of the reactor heat energy in addition to or instead of production of electricity by means of the direct Brayton cycle. Possible applications include

high-temperature process steam/cogeneration for industrial applications, high-temperature process heat for production of hydrogen and other alternative combustion fuels, and (by effective use of the waste heat from the MHR) cogeneration of electricity and heat energy for district heating or desalination.

Major process steam/cogeneration applications are highly energy intensive and diverse, including processes such as those associated with heavy oil recovery, tar sands oil recovery, coal liquefaction, coal gasification, steel mill processes and aluminum mill processes. In each of these applications, heat from the reactor can be used to generate high-temperature, high-pressure steam, a portion of which can be used to drive a steam turbine for electricity generation with the balance of the high-energy steam being used for the process.

High temperature process heat is a second major example of how the MHR can be extended to use its full temperature capability in non-electric applications. In terms of market application, transportation fuels represent the largest potential application for a process heat MHR system. Potential fuels include methane, synthetic gasoline, or hydrogen using various feedstocks. Hydrogen can be produced without the production of CO₂ by either (1) water electrolysis using electricity generated by a GT-MHR or (2) chemical conversion of water using thermochemical water splitting processes employing MHR high-temperature process heat.

District heating and desalination are heat energy/cogeneration applications that can be performed using the GT-MHR. At present, the GT-MHR has been optimized for the generation of electricity at the highest possible thermal conversion efficiency. Somewhat different optimizations are possible for heat energy/ cogeneration applications. The net thermal conversion efficiency for electricity generation can be reduced in favor of providing heat energy in the form of hot water at favorable temperature and pressure conditions for district heating or desalination. The higher temperature of the discharge heat makes some desalination options feasible with little or no penalty for electrical production. For LWRs, use of a backpressure (steam) turbine or extraction steam is needed for desalination applications, with a reduction in electrical generation. These applications can result in significantly increasing the net thermal utilization of the system since waste heat is minimized.

B-2.3.1 Economics 1.

- The system uses helium coolant at high temperature to drive a direct cycle gas turbine with an overall electric power generation efficiency of 48%.
- Detailed, Department of Energy (DOE)-sponsored cost evaluations of the base GT-MHR plant have shown that it is competitive with all other systems for new electricity generation capacity.
- Modular design permits incremental addition of capacity to minimize up-front capital costs.
- Flexibility of application makes MHR development and deployment economically attractive.

B-2.3.2 Economics 2.

- The design emphasizes maximum utilization of proven PMR technology and industrial gas-turbine/heat exchanger technologies.
- Modules are designed (e.g., ceramic materials, annular geometry, etc.) to preclude plant damage and to facilitate rapid recovery and restart after depressurization and core heatup transients.

- Confirmatory technology development programs are planned (e.g., fuel, magnetic bearings, heat exchangers, etc.) prior to plant construction and commissioning.
- The modular design permits the incremental addition of capacity to minimize risk of generic design problems.

B-3 RESEARCH AND DEVELOPMENT

B-3.1 Brief Summary of Progress to Date

The conceptual design of the GT-MHR was completed and fully documented by the end of 1997. Beginning in September 1998, the United States Government began providing funds for development of the GT-MHR in Russia for the disposition of excess Russian WPu. In the summer of 1999, following the United States Government decision to actively support the development, an international design review of the Russian conceptual design was held in Paris. The design review team concluded:

- The Russian design team had produced a well-thought-out conceptual design.
- There did not appear to be any "show stoppers."

The design review team identified the following key challenges (gaps):

- Performance/maintainability of the power conversion system
- Quality manufacturing/integrity of the Pu fuel
- Timely supply of the reactor and power conversion system vessels
- Upgrading the design to Western standards/licensing
- Ending with an economic product (i.e., commercial power system) for marketing outside Russia.

The following overall strengths of the GT-MHR cooperative program were identified:

- A bold and innovative nuclear power concept
- No readily apparent technical show stoppers
- Willing "customer" with good site for demonstration (i.e., a prototype)
- Builds on cumulative international experience
- Pooling of limited international resources
- Supportive of "Swords to Plowshares" goals
- Much lower cost for research, development, engineering and demonstration.

B-3.2 Description of the Research and Development Underway or Planned

Following the favorable Paris design review, the design team began preparing detail plans for performing the GT-MHR preliminary and final design in Russia. To execute the design work, an International GT-MHR project organization was formed, comprised of the Russia Federation (RF), the United States, and other international participants. The program is being carried out under a Plutonium Disposition Steering Committee chaired jointly by Minatom and the DOE National Nuclear Security Administration. The Steering Committee sets top-level program strategy and goals.

The lead RF organization for preparation of the GT-MHR preliminary and final design is the Experimental Machine Building Bureau (OKBM) with technical support from an international team including, Framatome and Fuji Electric. There is also substantial research and development (R&D) support provided by the International Science and Technology Center and the Japanese Atomic Energy Research Institute. OKBM is a leading RF scientific-industrial organization of nuclear machine building with capabilities to perform comprehensive development of various nuclear reactor plants. OKBM has overall responsibility for preparation of the preliminary and final design and performance of the required R&D work. Key R&D testing activities to cover the challenge or “gap” areas that are to be completed during the preliminary and final design include the following:

- Fuel tests to qualify TRISO-coated particle fuel for GT-MHR performance parameters and to provide data for validation of fuel performance models. The planned fuel tests include:
 - Tests of fuel samples made on bench-scale equipment and irradiated under representative reactor conditions to verify the high burnup performance of TRISO-coated PuO₂ particles for the GT-MHR temperature, fluence, and burnup
 - Tests of fuel fabricated by full-size production equipment under representative reactor conditions
 - Tests of irradiated fuel heated under conditions representative of accidents to determine coating integrity limits and high-temperature fission product retention capability.
- Reactor physics tests to validate the reactor physics codes. These tests will be compared against a carefully selected series of benchmark calculations designed to test important features, such as reactivity behavior with burnup, temperature coefficient of reactivity, etc.
- Thermal hydraulic tests to provide the data needed for flow distributions and core component pressure drops, thermal mixing at the core outlet, core column flow induced vibrations, and verification of core dynamic stability.
- Materials tests on reactor metals and ceramics to obtain supplemental data on material properties covering GT-MHR specific service conditions.
- Tests on the vessel materials to obtain additional property data, particularly on heavy sections and welds. Tensile and Charpy V-notch tests needed to determine the neutron-induced, nil-ductility transition temperature shifts for plate, forgings, weldments, and weld heat-affected zones.
- Reactor core graphite material tests on irradiated and unirradiated graphite specimens to determine strength, fracture and fatigue, thermal properties, and dimensional change and creep, as well as tests to characterize graphite oxidation.

- Turbomachine tests to verify key performance characteristics, including surface coating tests where materials are in contact and subject to movement, flow distribution tests to characterize flow distributions in the compressor and turbine inlet and outlet ducts, and rotor dynamics tests.
- Turbomachine bearing tests to verify the turbomachine journal and thrust magnetic and catcher bearings.
- Seal tests to verify the performance of the seals between the turbomachine and the various interfacing assemblies.
- Recuperator tests to verify the performance characteristics of the counterflow, gas-to-gas recuperator heat exchanger, including flow distribution tests, material tests, structural integrity tests, and tests to determine heat transfer and pressure drop characteristics.

Key R&D activities in the area of innovative design or economic-based improvements include the following:



- Shutdown Heat Exchanger (SHE) tests to assess SHE inlet flow distribution, shroud and seal performance, and acoustic noise generation from potential vortex shedding, and to demonstrate helical coil in-service inspection with eddy current probe.
- RCCS component and integrated tests to determine the effective conductivity of the graphite core, buoyancy-induced fluid mixing in the enclosures along the core, and emissivities of metal surfaces, including the RCCS panels, reactor vessel and metallic reactor internals.
- Fuel Handling System (FHS) component and integrated tests to verify that FHS mechanical, electrical, and electronic hardware meet plant performance and reliability requirements.
- Generator tests to verify the design for operation in the GT-MHR helium environmental conditions.
- Handling equipment tests to verify the design and operation of the turbomachine and generator handling equipment.
- Precooler/intercooler tests to verify the performance and inspectability of these heat exchangers.







Screening for Potential Scoresheet







Concept Name: **PMR (GT-MHR Reference)**





Summary Evaluation: Retain Reject

Comparison to Reference	Much Worse	Worse	Similar	Better	Much Better	Comments
	--	-	=	+	++	

Sustainability 1						<p>The reference GT-MHR fuel cycle utilizes LEU (<19.9% enriched), but PMR cores have been designed to utilize a broad spectrum of fissile and fertile materials including LEU/Th, (Pu, U), (Pu, Th), HEU, and WPu. Relatively hard thermal neutron spectrum produced by graphite moderator and neutronically transparent He coolant permits burnups of ~120,000 MWD/T with LEU fuel without recycle. Because of its higher efficiency, the GT-MHR utilizes less fuel and produces less waste per MWhe. Likewise, the discharge of waste heat is typically about half that of LWRs.</p>
SU1-1: Fuel utilization						
SU1-2: Fuel cycle impact						
SU1-3: Use of other resources						

Sustainability 2					High thermal efficiency results in generation of fewer heavy metal radionuclides per MWh. Spent GT-MHR fuel elements may be a final waste form, which require no further processing or additional barriers (e.g., overpack).
SU2-1: Waste minimization					
SU2-2: Environmental impact					
SU2-3: Stewardship burden					
Sustainability 3					LEU (<19.9% enriched); uranium never in metallic form; unfavorable isotopics at discharge. U and/or Pu very difficult to recover from
SU3-1: Material life cycle vulnerability.					
SU3-2: Application of extrinsic					
SU3-3: Unique characteristics					

Safety and Reliability 1					<p>Fuel can operate in excess of 1600°C without loss of particle coating integrity; GT-MHR designed to passively maintain fuel temperatures below this level for all events with probabilities of $>5 \times 10^{-7}/\text{yr}$. Peak fuel temperatures do not occur for several days after loss of coolant because of low core power and large heat capacity of graphite core components.</p> <p>The helium coolant is neutronically inert and is not subject to any phase changes. Strongly negative temperature coefficient of reactivity from ambient temperature to bounding accident temperatures. Coupled with very large core temperature margins, this attribute provides passive response to anticipated transients without scram.</p>
SR1-1: Public/worker-routine exp.					
SR1-2: Worker safety-accidents					
SR1-3: Reliability					
Safety and Reliability 2					<p>Fuel and core can operate well in excess of 1600°C without structural damage, and the GT-MHR design passively maintains temperatures below this level for events with probabilities of $>5 \times 10^{-7}/\text{yr}$. Reactor system designed (e.g., ceramic materials, annular geometry, etc.) to facilitate rapid recovery and restart, even after postulating a simultaneous loss of coolant and loss of flow transient.</p>
SR2-1: Facility state transparency					
SR2-2: System model uncertainty					
SR2-3: Unique characteristics					

Safety and Reliability 3					Plant designed to meet EPA Protection Action Guides at 425-m Exclusion Area Boundary (EAB) for all events with frequency of $>5 \times 10^{-7}$ /year (i.e., LPZ located at EAB)
 -1: Robust mitigation features					
SR3-2: Damage/dose understood					
SR3-3: No additional individual risk					
SR3-4: Comparable societal risk					

<p>Economics 1 & 2</p>				<p>The system uses helium coolant at high temperature to drive a direct cycle gas turbine with an overall electric power generation efficiency of 48%.</p> <p>Detailed, DOE sponsored, cost evaluations of the base GT-MHR plant have shown that it is competitive with all other systems for new electricity generation capacity.</p> <p>Modular design permits incremental addition of capacity to minimize up-front capital costs.</p> <p>Flexibility of application makes MHR development and deployment economically attractive.</p> <p>Maximum utilization of proven PMR technology and industrial gas-turbine/heat exchanger technologies</p> <p>Module designed (e.g., ceramic materials, annular geometry, etc.) to preclude plant damage and to facilitate rapid recovery and restart after depressurization and core heatup transients</p> <p>Confirmatory technology development programs planned (e.g., fuel, magnetic bearings, heat exchangers, etc.) prior to plant construction and commissioning</p> <p>Modular design permits incremental addition of capacity to minimize risk of generic design problems.</p>
<p>EC-1: Low capital costs</p>				

APPENDIX C

Very-High-Temperature Reactor (VHTR) Systems Summary Report

CONTENTS

ACRONYMS.....	85
C-1 INTRODUCTION.....	89
C-1.1 General Aspects	89
C-1.2 Former VHTR Technology Developments.....	93
C-2 CONCEPT DESCRIPTION.....	101
C-2.1 Features of the VHTR Set of Concepts.....	101
C-2.2 Concept Description.....	103
C-2.3 Reference Concept Description.....	106
C-3 POTENTIAL OF THE CONCEPT SET FOR MEETING GENERATION IV GOALS	108
C-3.1 Evaluation against Criteria/Metrics.....	108
C-3.2 Summary of Concept Potential (Strength & Weaknesses).....	110
C-4 TECHNICAL UNCERTAINTIES (R&D NEEDS).....	111
C-5 TECHNICAL INNOVATIONS (DESIGN IMPROVEMENTS).....	114
C-6 STATEMENT OF OVERALL CONCEPT POTENTIAL VERSUS R&D RISK.....	114
C-7 SCREENING FOR POTENTIAL SCORESHEET.....	115
C-8 REFERENCES	116

FIGURES

C-1. Operational temperatures in various industries and coolant outlet temperatures of nuclear reactor plants	90
C-2. Thermal efficiency vs. gas-turbine inlet temperature in electricity generation with VHTR	91
C-3. Benefits of enhanced thermal efficiency	91
C-4. 500 MWth Prototype Nuclear Process Heat (PNP-500).....	95
C-5. Prototype plant with 500MWt in Nuclear Steelmaking System (NSS) project planned in Japan (1973-1980).....	97
C-6. HTTR in Japan; (Coolant outlet temperature is 950°C, 30 MWt).....	98
C-7. Conceptual design of HTTR hydrogen production system [Shiosawa, et al. 2000].....	99

C-8. Combination of three chemical reactions in thermochemical IS process for water splitting [Shimizu, et al. 2000]	100
C-9. Design study of GTHTTR-300 in JAERI [Yan, et al. 2000]	101
C-10. Coolant outlet temperatures in various nuclear reactors.....	103
C-11. Relationship between VHTR concepts submitted and ongoing HTRs.....	106
C-12. Schematic drawing of the A-HTR with gas turbine system	107
C-13. Schematic view of the A-HTR with hydrogen production system.....	107

TABLES

C-1. Characteristics of the VHTR concepts	92
C-2. Former projects for nuclear process heat.....	94
C-3. Main specification of VHTR concepts	104

ACRONYMS

AGR	Advanced Gas-Cooled Reactor
A-HTR	Advanced High-Temperature Reactor
APBR	Annular Pebble Bed Reactor
AVR	Arbeitsgemeinschaft Versuchsreaktor (in Germany)
BMI	Federal Ministry of Internal Affairs
CHP	combined heat and power
EAB	Exclusion Area Boundary
ECCS	emergency core cooling system
ERANS	Engineering Research Association of Nuclear Steelmaking
FZJ	Forschungszentrum Juelich
GCR	gas-cooled reactor
GTHTR	Commercial version of the Thorium Hochtemperatur Reaktor (in Germany)
GT-MHR	Gas Turbine – Modular Helium Reactor
HKV	hydro-gasification of lignite
HLW	high-level waste
HTR	High-Temperature, Gas-Cooled Reactor
HTTR	High-Temperature Engineering Test Reactor (in Japan)
HWR	heavy water reactor
IHX	intermediate heat exchangers
IS	iodine-sulfur
JAERI	Japanese Atomic Energy Research Institute
LEU	low enriched uranium
LMFBR	Liquid Metal-Cooled Fast Breeder Reactor
LWR	light water reactor
MHR	Modular Helium Reactor

NHSS	Nuclear Heat Supply System
NPH	nuclear process heat
NSS	Nuclear Steelmaking System
PCRv	pre-stressed cast-iron reactor vessel
PNP	Prototype Nuclear Process Heat project
R&D	research and development
SR	steam reformer
THTR	Thorium Hochtemperatur Reaktor (in Germany)
UNTREX	Ultra High-Temperature Reactor Experiment
VHTCGR	Very High-Temperature Gas-Cooled Reactor
VHTR	Very-High-Temperature reactor
WKV	steam gasification process for hard coal

Appendix C

Very-High-Temperature Reactor (VHTR) Systems Summary Report

C-1 Introduction

C-1.1 General

This appendix describes the concept set for a Very-High-Temperature Reactor (VHTR) system that extends the capabilities of the high-temperature reactors described in Appendices A and B to achieve further improvements in thermal efficiency and potentially open up additional high-temperature applications. The primary changes required compared to the high-temperature gas reactors are in the areas of plant materials and material development for fuels.

Currently, about 30% of world's primary energy consumption is used for electricity generation; approximately 15% is used for transportation; and the remaining 55% is converted into hot water, steam and heat for different purposes in households and industries. Nuclear energy is only contributing about 17% to the total electricity generation worldwide. Thus, there is still a huge potential for nuclear power to not only further increase its contribution to the electricity market, but also make inroads into the heat market and to follow the trend towards highly efficient Combined Heat and Power (CHP) production. As large grids for heat supply systems do not exist, modular reactors with small or medium power size are more appropriate.

The present generation of large light water reactors (LWRs) and heavy water reactors (HWRs) has been extensively developed and is a very reliable power source. However, due to the low temperature at the reactor outlet, an LWR or HWR electrical generating facility is only about 35% thermally efficient. This is compared to the newest fossil-fired plants, where the thermal efficiency approaches 42% with a steam turbine and about 50% with a combined cycle of gas and steam turbines. Nevertheless, LWRs and HWRs could contribute to supply low-temperature heat for non-electric applications (e.g., low-grade process steam, hot water, heating), but would face a considerable loss in electricity generation efficiency in the CHP mode as a result of their low coolant temperature. Liquid-Metal-Cooled Fast Breeder Reactors (LMFBR) and gas-cooled reactors like the Advanced Gas-cooled Reactor (AGR) and High Temperature gas-cooled Reactor (HTRs) provide higher efficiencies and better thermal conditions for new applications and market sectors, as shown in Figure C-1.

Further temperature increase for nuclear power plants will lead to higher thermal efficiencies as indicated in Figure C-2. For example, a temperature of 1200°C makes it possible to approach a thermal efficiency of 60%. This not only has an impact on the cost of electricity but also strong benefits for a reduction of fission product waste /kWh and lower reject heat and cooling water requirements as shown in Figure C-3. Thus, there is a real motivation for further enhancing the thermal efficiency step-by-step, as is also the case with the competing fossil-fired plants that have realized remarkable improvements in the last decades whereas nuclear plants retained the low thermal efficiency of 35%.

Figure C-1. Operational temperatures in various industries and coolant outlet temperatures of nuclear reactor plants.

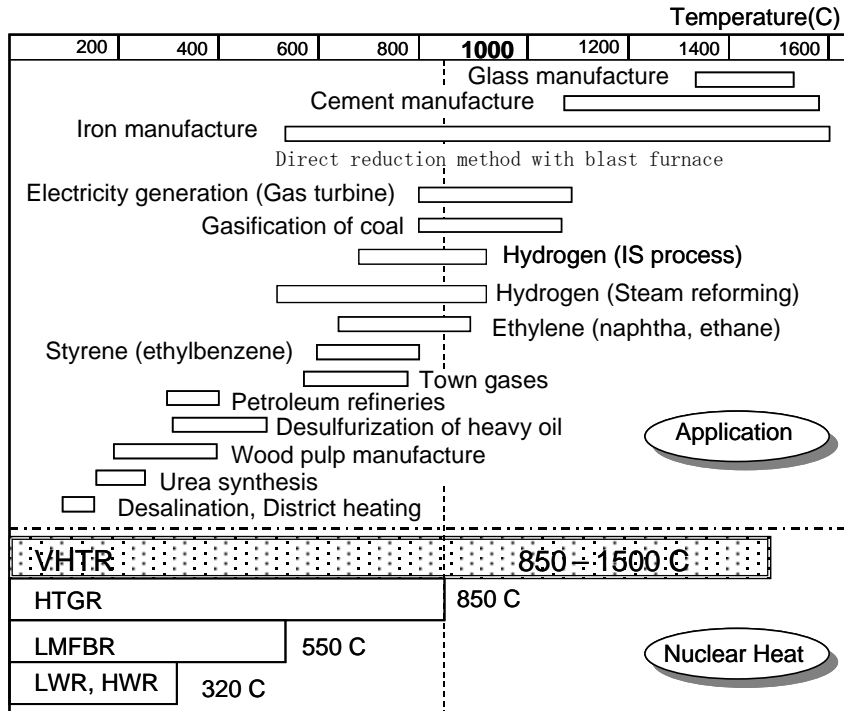

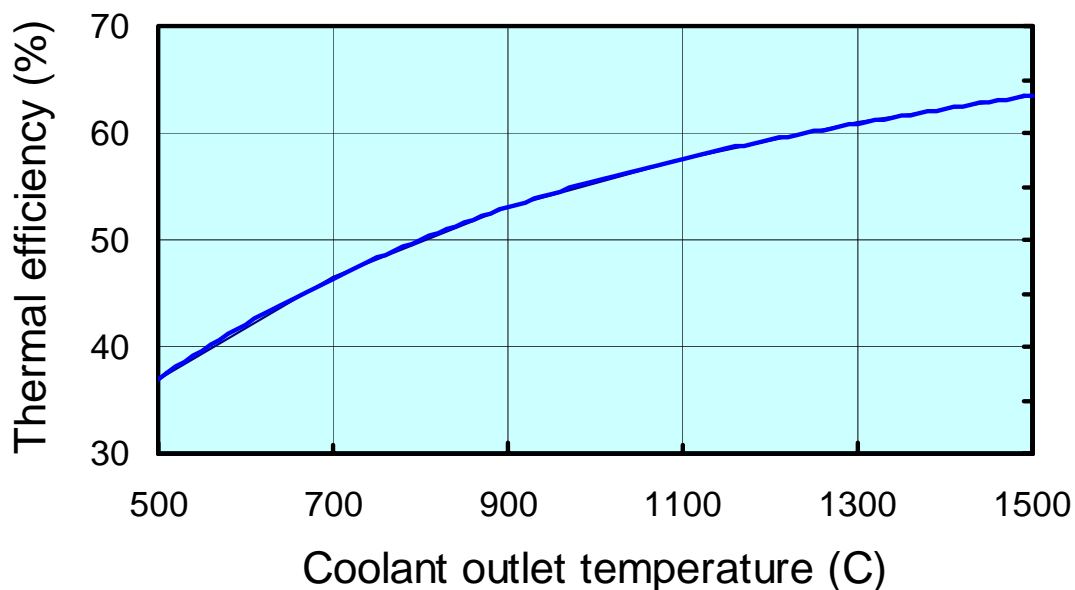

Figure C-2. Thermal efficiency vs. gas-turbine inlet temperature in electricity generation with VHTR.

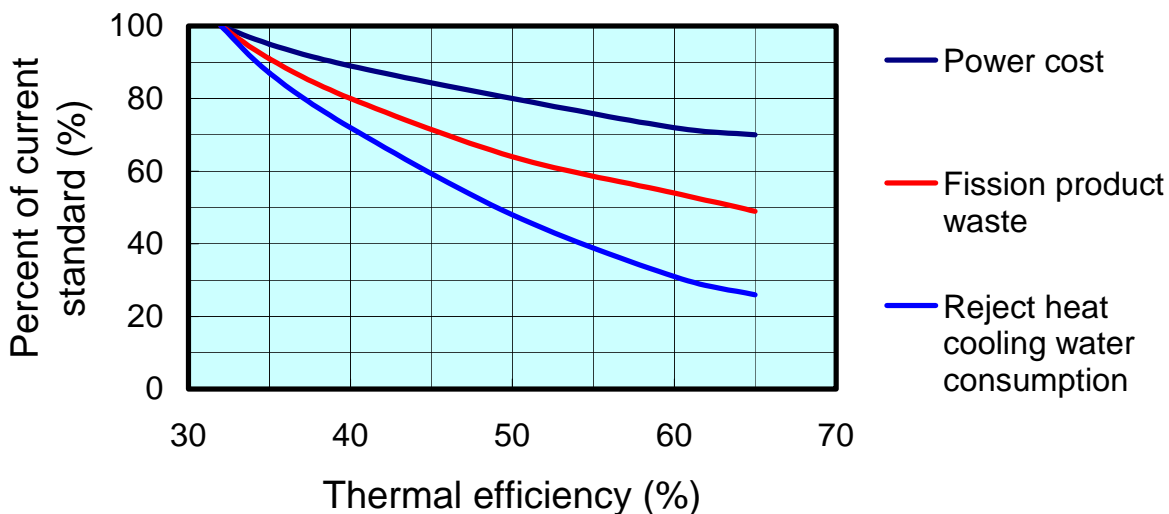

Figure C-3. Benefits of enhanced thermal efficiency.

Besides high efficient electricity generation, CO₂-free hydrogen production is expected to be a key application for the future. This not only address the so-called hydrogen economy (e.g., hydrogen cars, hydrogen-driven airplanes, fuel cell applications, raw material for chemical products, etc.) but also crude oil conversion technologies, fertilizer production (ammonia), and chemical/metallurgical processes currently using large quantities of hydrogen produced via fossil fuel (e.g., natural gas). Hydrogen production using nuclear heat will considerably improve utilization of petroleum resources and reduce

dependency on foreign energy imports. It is expected that the energy required for hydrogen generation for refineries and chemical plants by 2010 will exceed the current energy production of all nuclear reactors in the United States [Forsberg and Peddicord 2001].

Former HTR demonstration reactors (Peach Bottom, Fort St. Vrain, and Thorium Hocktemperatur Reaktor [THTR]-300) were operated at temperatures around 750°C using steam cycles at efficiencies near to 40%. The Arbeitsgemeinschaft Versuchsreaktor (AVR) already achieved a more than 950°C core outlet temperature, similar to the objective for the Chinese HTR-10 and Japanese High Temperature engineering Test Reactor (HTTR) prototype reactors that will—in contrast to AVR—also have a high-temperature heat conversion system. Commercial HTR designs currently being considered are limited in temperature to about 850°C, mainly because of for the high temperature capabilities of the metallic components.

With this background, the VHTR system is presented as a concept set targeting the following items achieved through fuels and plant materials developed to operate under considerably higher temperatures than current water reactors or HTRs. The general characteristics of a VHTR system would include:

- High temperature at coolant outlet (> 850°C)
- High power density (> 6MW/m³)
- Long lifetime of fuel and material (> 40 years)
- Wide safety margin
- Longer burnup (> 150-200 GWd/ton).

In addition, high-temperature fuel and material can stretch burnup, which is dependent not only on fuel temperature/loading-time but also on neutron fluence. Table C-1 lists the characteristics of the VHTR concepts. The important research and development (R&D) subjects are listed in Table C-1 and further described in Section C-4.

Table C-1. Characteristics of the VHTR concepts.

Technical uncertainty (R&D needs) (see Section C-4)		Technical innovation (Design improvement) (see Section C-5)	Potential (see Section C-6)
R&D subject in VHTR	Solution example		
- Fuel with high temperature capability	- ZrC	- Higher coolant outlet temperature (> 850°C) - Higher power density (> 6MW/m ³)	- Higher thermal efficiency - Enlargement of application fields such as hydrogen production
- Material with high temperature capability	- Compound material - Fiber reinforced ceramics - Fully ceramic component	- Longer lifetime	

Table C-1. (continued.)

Technical uncertainty (R&D needs) (see Section C-4)		Technical innovation (Design improvement) (see Section C-5) (> 40 years)	Potential (see Section C-6)
R&D subject in VHTR	Solution example		
- Heat transfer augmentation for decay-heat removal	- Heat pipe	- Wider safety margins - Longer burnup (> 150-200 GWD/ton)	- Compaction of reactor core - Easy operation - Small amount of fuel and waste

These potentials imply considerable improvements in the fuel design and in material properties to withstand high operational temperatures over several hundred thousand hours and preclude replacement of components during the lifetime of the plant. High-temperature alloys, fiber reinforced ceramics, compound materials, and ZrC coatings for the fuel are potential developments to achieve higher operating temperatures. The benefit of these developments is not restricted to VHTR applications but is applicable to other HTR applications irrespective of the core design. Such R&D will not only provide the opportunity to improve the thermal efficiencies and extend the potential applications for nuclear process heat (NPH), but may also improve safety margins and reduce costs by use more compact components, if heat transfer can be augmented. Thus, the VHTR concepts can be an important motivation for long-term R&D for other HTR concepts.

C-1.2 Former VHTR Technology Developments

Former HTRs, such as Peach Bottom, Fort St. Vrain, and THTR-300, did not need coolant outlet temperatures higher than 700°C because a steam turbine cycle was used. In the early 1960s, initial studies were undertaken regarding the use of high-temperature gas turbines and NPH from an HTR for:

- Chemical processes and coal gasification/liquefaction
- Steel making
- Hydrogen generation
- Oil refineries and oil shell processing
- Long-distant energy transport by latent heat, etc.

The motivation to make use of high-temperature NPH can be seen from the following conversion effectiveness for the energy content of the product in relation to the coal energy equivalent:

<i>Autothermal coal gasification:</i>	<i>51-66%</i>
<i>Gasification by steam injection from HTR (420 °C):</i>	<i>59-83%</i>
<i>Allothermal gasification with VHTR heat (950 °C):</i>	<i>96-100%</i>

The oil crises in the 1970s gave further incentive to substitute nuclear plants for oil and coal power plants and to convert indigenous coal (lignite and hard coal) into synthesis gas by gasification processes. Several NPH projects (see Table C-2) were undertaken in the United States, Germany, France, Japan, China, Indonesia and Russia to explore such possibilities.

Table C-2. Former projects for nuclear process heat.

Project Name	Planned plant Operated facility	Year	Country
Prototype Nuclear Process heat (PNP) Projects	Plant: PNP-500	1975-1992	Germany
NFE Project (Long distant transport of nuclear energy converted into chemical form to the consumers)	Facility: ADAM/EVA	1972-1985	Germany
Nuclear Steelmaking System (NSS) Project	Plant: 500MWt Prototype Nuclear Plant, FM-50 Facility: EM-1.5 (Helium gas test loop with 1.5MWt)	1973-1980	Japan

Considerable component testing and material development has already been done in these projects and provides a sound basis for further development. As shown above, nuclear suppliers, research organizations and coal mining industries in Germany established the PNP project in 1975 with goals to:

- Adapt the Nuclear Heat Supply System (NHSS) for higher temperatures (950°C)
- Develop and test a Steam Reformer (SR) for hydro-gasification of lignite (HKV)
- Develop and test an Intermediate Heat Exchanger (IHX) and Steam Gasification Process for hard coal (WKV).

By the end of 1976, conceptual designs for 6-loop 3000 MWt NPH plants with pod boiler pre-stressed cast-iron reactor vessel (PCRIV) for the HKV and WKV gasification processes were presented as a base for deriving the features of a common prototype plant. It was decided to design a 500 MWt prototype that incorporated heat exchanger systems, an IHX, and a SR-loop of 250 MW each (see Figure C-4).

The start of construction of the prototype plant was planned for the mid-1980s. The PNP project was complemented by R&D on the cold, long distant transport of nuclear energy converted into chemical form being conducted by the NFE Project (see Table C-2). The endothermic reformation of methane by HTR was used to generate a combination of hydrogen and carbon monoxide gases to be transported by pipelines to the methanization station, where the back reaction released the reaction heat for multiple uses. The recovered methane could then be fed back to the HTR steam reforming plant in a closed cycle or used as substitute natural gas in an open cycle. This process was successfully demonstrated at Forschungszentrum Juelich (FZJ) by a 10 MW methanization facility (ADAM) and the related steam

reformer unit (EVA 2) for more than 8000 hours. The PNP project reached the goal of demonstrating the operation of the ADAM/EVA concept under near-commercial conditions in 1984.

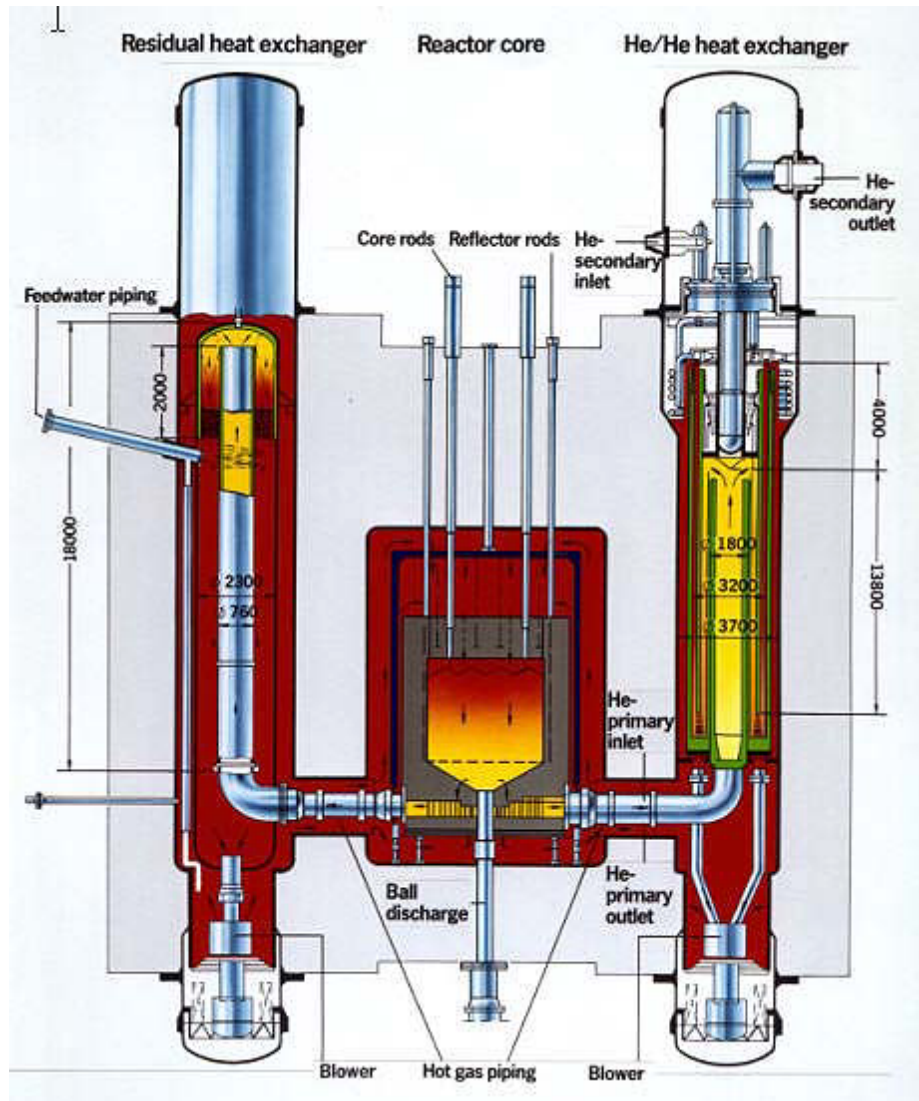

Figure C-4. 500 MWth Prototype Nuclear Process Heat (PNP-500)

Large test facilities for the other components of the prototype plants up to the 10 MW range were built and successfully operated. This was accompanied by a rather comprehensive material qualification program that proved the feasibility of a lifetime of more than 100,000 hours for high-temperature components like steam reformer, IHX, hot gas ducts, etc. The relaxation of energy supply restraints following the oil crisis led to an interim phase for the re-assessment of the technical feasibility and the licensability of the PNP-500 concept that was confirmed by a special advisory board of the Federal Ministry of Internal Affairs (BMI) without major open issues.

In 1987, independent engineering and economic studies on hard coal gasification and other potential applications of NPH determined that the competitiveness for substitute natural gas, produced on the base of German hard coal, was fading away due to significant cost reductions for oil and gas on the world market. This trend hit the other conventional coal gasification processes in the same way. Alternate applications of high temperature NPH were identified (e.g., in oil refineries and aluminum oxide

production), and it was recognized that smaller modular units were better suited for coupling to process heat applications than single big plants. Thus, modular designs of 170MWt with either steam reformer in direct cycle or IHX were included as alternatives to the monolithic designs. The PNP project was terminated in 1992 in conjunction with the growing anti-nuclear movements after the Chernobyl accident, failure of commercial introduction of HTR steam cycle plants in the electricity and process heat market, and the subsequent reduction of the national HTR program in Germany.

The first step toward applying NPH concepts in Japan was the Nuclear Steelmaking System (NSS) project, an R&D program to address direct steelmaking using high temperature reducing gas. The Engineering Research Association of Nuclear Steelmaking (ERANS), an industrial consortium of fifteen companies and one institute, conducted the project under financial support from the Agency of Industrial Science and Technology and the Ministry of International Trade and Industry. This program, which concluded in 1980, was carried out under the following sub-themes:

- High temperature IHX
- Heat resistance super alloys
- High temperature heat insulating materials
- Reducing gas production unit
- Reduced iron production unit
- Total system for nuclear steelmaking.

These sub-themes were the principal constituents in establishing the fundamental engineering technologies required for designing, constructing, and operating a nuclear steelmaking pilot plant, namely the FM-50 experimental HTR. As part of its work, ERANS constructed the EM-1.5 helium gas loop, which simulated FM-50, to test IHXs, high temperature isolation valves, etc. Test results were reflected in a conceptual design of a prototype plant rated at 500 MWt, as shown in Figure C-5.

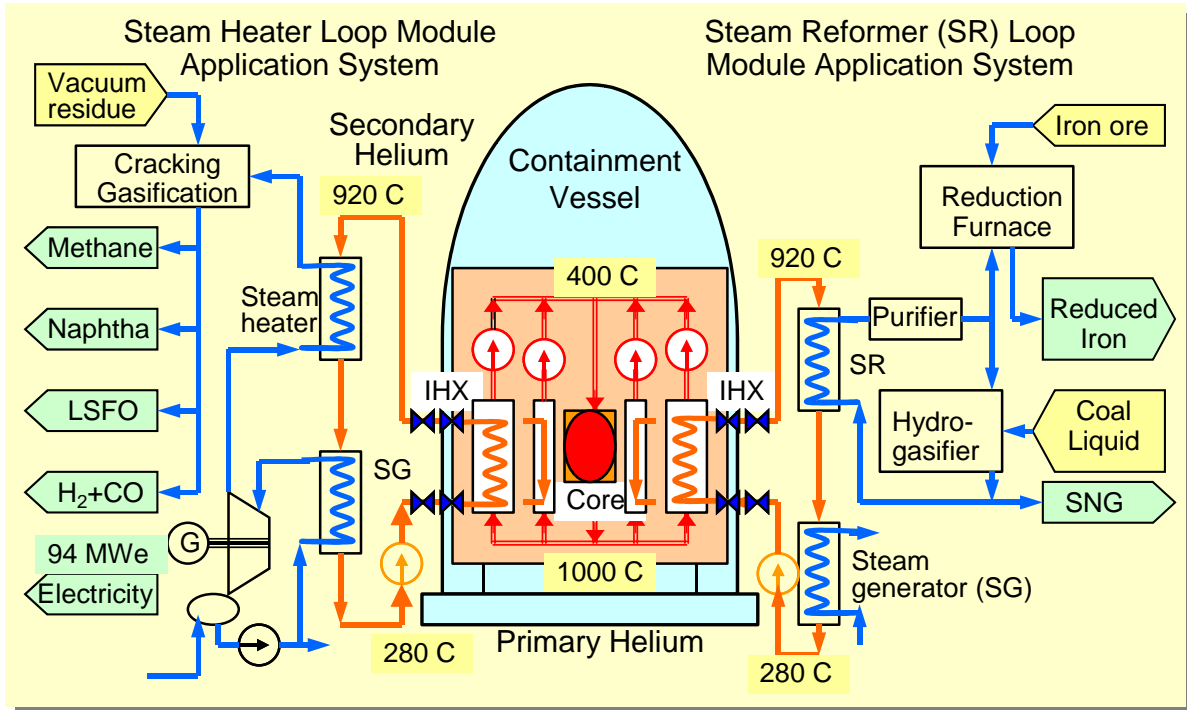

Figure C-5. Prototype plant with 500MWt in Nuclear Steelmaking System (NSS) project planned in Japan (1973-1980).

C-1.3 Ongoing Projects on VHTR

The coolant outlet temperature of the Chinese HTR-10, which attained its first criticality in December 2000, is 900°C; the Japanese HTTR, which attained its first criticality in November 1998, is aiming toward 950°C after a full power test with 850°C. Figures A-3 and C-6 show the HTR-10 and HTTR, respectively.

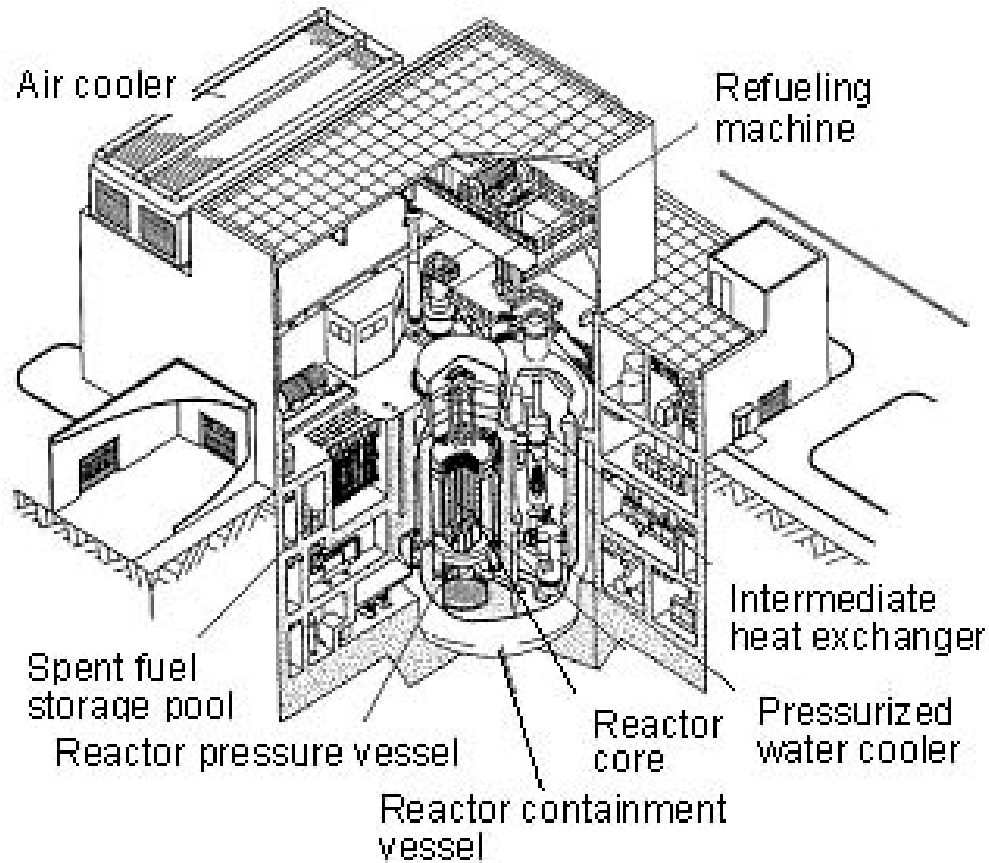
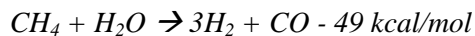

Figure C-6. HTTR in Japan; (coolant outlet temperature is 950°C, 30MWt).

The HTR-10 has a steam turbine driving an electrical generator. Following initial testing, a gas turbine will be added to the HTR-10. It is also planned to add a nuclear heat application system, such as a methane steam reforming process. Currently, a power rising test aiming at full power of 10MW is being carried out in the HTR-10.

In the HTTR project at Japan Atomic Energy Research Institute (JAERI), a full power of 30MW at a coolant outlet temperature of 850°C will be attained by the end of 2001. Figure C-7 shows the planned HTTR hydrogen production system [Shiosawa, et al. 2000]. Key components, such as IHX, SR, and super-heater, will be qualified for nuclear use in the course of the HTTR project and can be applied to commercial follow-up reactors thereafter. The helium coolant of the secondary cooling loop first enters a steam reformer, where heat is provided to methane and steam. These are then primarily converted into carbon monoxide and hydrogen in the presence of a catalyst according to the following formula:



This reaction is strongly endothermic and can consume substantial quantities of nuclear heat to maintain the chemical process. The carbon monoxide can either be converted with steam to hydrogen and carbon dioxide or used for production of methanol for transport and as a chemical raw material. These processes are also used in the conventional commercial plants where heat is provided by combustion of fossil fuels. Nuclear process heat can help reduce the CO₂ emissions at the conversion plant or even eliminate them when applying thermochemical water splitting or hot electrolysis. All hydrogen production processes can be combined with HTRs of any core type such as pebble type and block type.

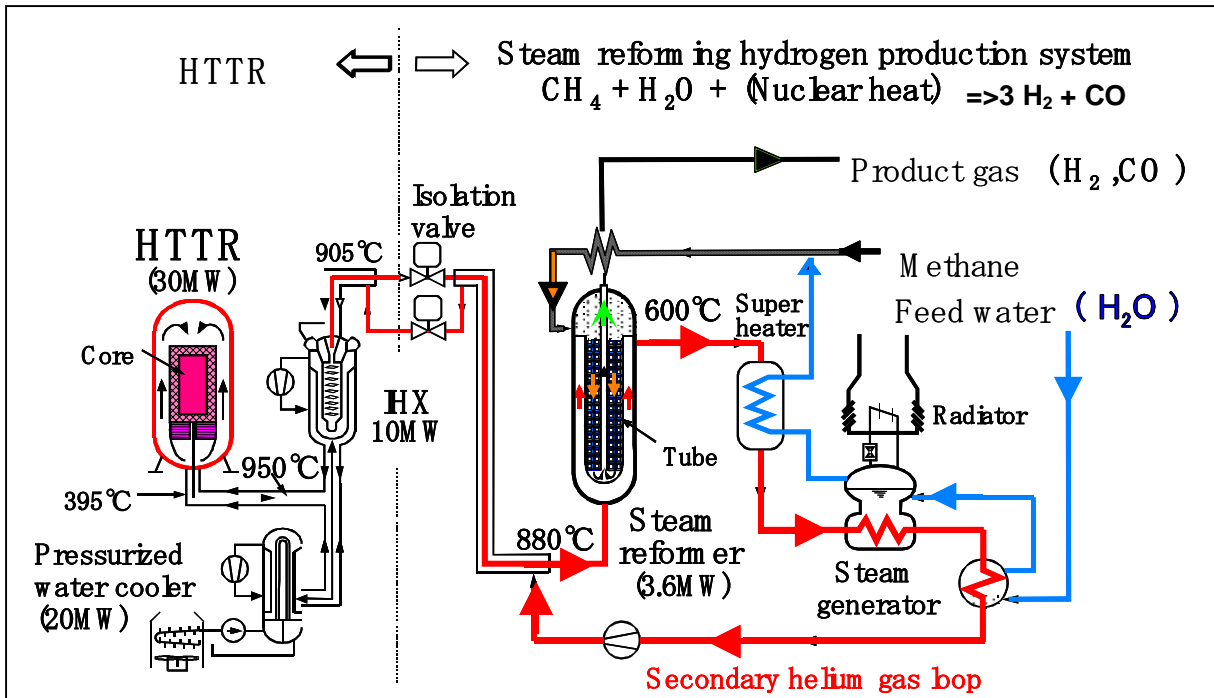

Figure C-7. Conceptual design of HTTR hydrogen production system [Shiosawa, et al. 2000]

Another important thermochemical process for hydrogen production is the iodine-sulfur (IS) process, with which hydrogen can be produced from only heat and water. Though temperatures greater than 4000°C are required for direct pyrolysis of water, combining two more chemical reactions enable water to be decomposed into hydrogen and oxygen at fairly low temperature (~900°C). The IS process consists of three chemical reactions operating at temperatures lower than 900°C, as shown in Figure C-8. It should be noted that iodine and sulfur are recirculating elements (i.e., it is not necessary to supply those to the process since they act like a chemical catalyst). The chemical theory of the thermochemical IS process has been confirmed, and hydrogen was continuously produced for 48 hours in JAERI using this process [Shimizu, et al. 2000].

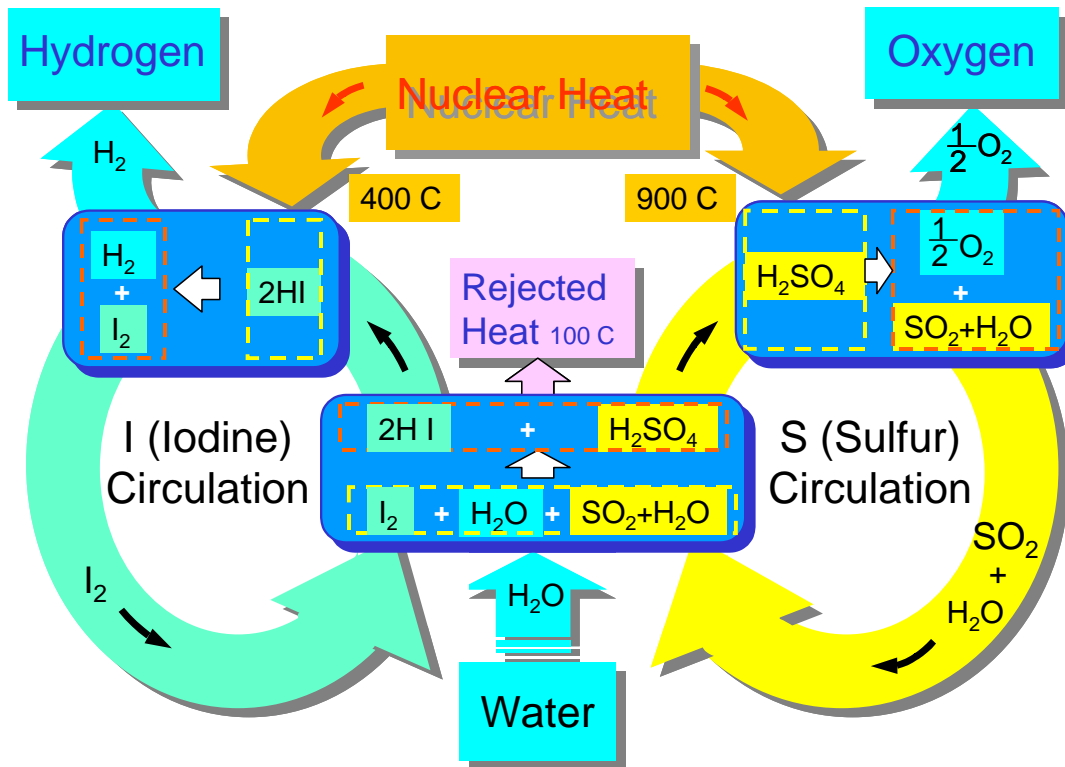

Figure C-8. Combination of three chemical reactions in thermochemical IS process for water splitting [Shimizu, et al. 2000]

A simulation of the HTTR hydrogen production process (methane steam reforming) system at 1/30 scale is being constructed and will be completed by the end of 2001 [Shiosawa, et al. 2000]. In parallel, R&D on the thermochemical IS process for water splitting is being carried out. A continuous production test in a closed cycle facility with a production rate of 50 liters per hour will be performed as the second phase [Shimizu, et al., 2000]. In addition, the commercial GTHTTR-300 (for electrical power generation) is being designed for a near-term deployment at JAERI (see Figure C-9) [Yan, et al., 2000]. The Ministry of Education, Culture, Sports, Science and Technology of Japan has assigned the associated R&D to JAERI.

The Japanese and Chinese test reactors will provide the opportunity to develop the necessary processes (e.g., for nuclear hydrogen production) and to enter into VHTR system applications within the present decade and. Due to the importance of this development with regard to the anticipated hydrogen economy and carbon-based climate change problems, these NPH developments should provide a backbone for the medium to long-term Generation-IV R&D programs.

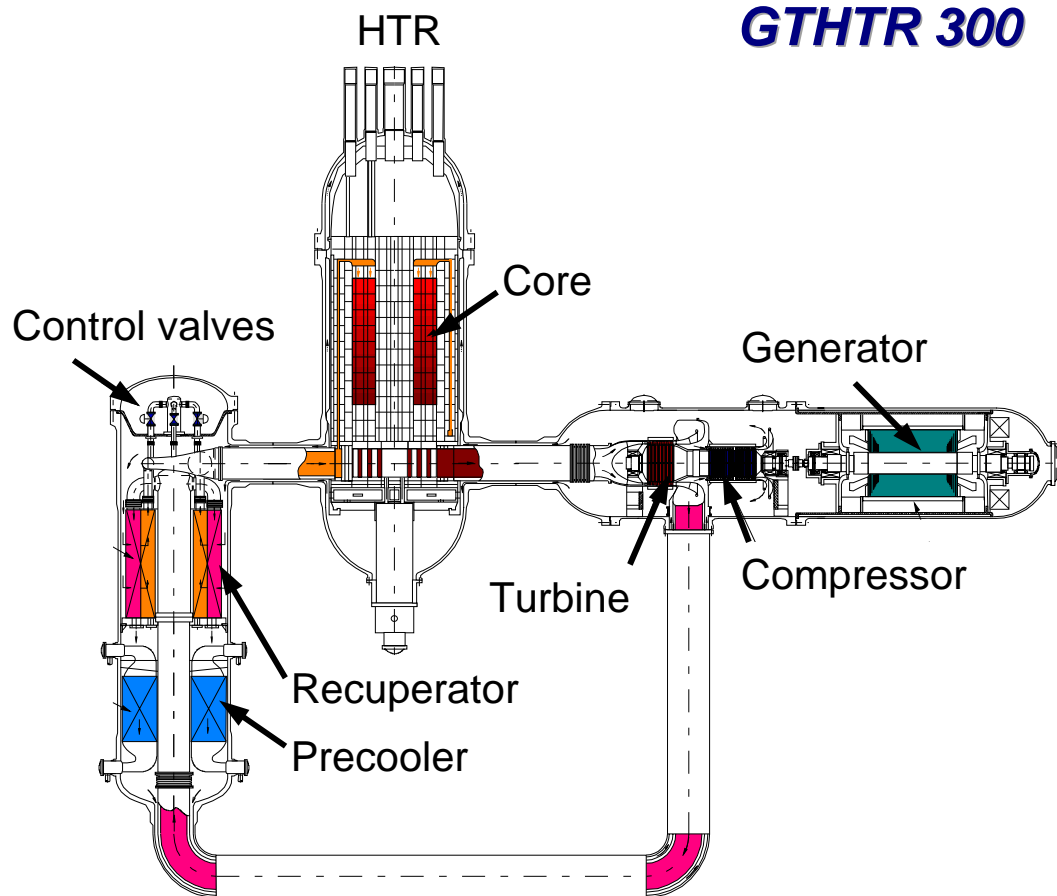

Figure C-9. Design study of GTHTR-300 in JAERI [Yan, et al. 2000]

C-2 Concept Set Description

C-2.1 Features of the VHTR Set of Concepts

As described in Section C-1.1, high temperature not only leads to high thermal efficiency as shown in Figure C-2 but also increases the types of potential heat applications. Though nuclear heat application is limited in its range to temperatures less than 850°C in current commercial design concepts, temperatures up to around 1500°C would cover the requirements of almost all industries, as shown in Figure C-1. However, the classical high temperature processes can be modified such that nuclear heat supply system temperatures around 1000°C are sufficient, as has been shown by the Japanese NSS project.

The total amount of hydrogen production in the world is about 800Gm³ (1x10¹⁹J) a year; however, this is only 3% of the world's primary energy usage (about 35x10¹⁹J). Fuel cell powered automobiles are attracting increasingly greater public attention worldwide. Fuel cell concepts for automobiles typically use methanol or hydrogen, with hydrogen anticipated to be the fuel of choice. Hydrogen forms water during its combustion and is a "clean energy," with no carbon-based emissions. Use of fossil fuels (e.g., natural gas) for hydrogen production, as is presently the case, results in carbon emission; hence, the entire cycle is not clean. Nuclear power is a considerably cleaner candidate as the primary energy source for producing the large quantities of hydrogen that are or could be utilized in transportation and

petrochemical industry sectors. Other clean, natural energy sources (wind, solar, biomass) are not yet competitive due to their low energy density.

In the United States, California car companies were informed that 10% of new automobiles manufactured each year must be zero-release beginning in 2003. Worldwide, automobile companies indicate commercial fuel cell powered automobiles will be available starting in 2003. In Japan, fuel cell automobiles are being actively discussed and a numerical target of 5 million in the market by 2020 was suggested for fuel cell powered automobiles. Conceptually, about ten HTR plants with a rating of 200MWt per reactor using a methane steam reforming process would be necessary to produce enough hydrogen for 5 million fuel cell cars.

Temperatures of around 950°C at the inlet of the chemical reactor are required to produce hydrogen. Higher temperature makes it possible to apply various methods, such as direct pyrolysis of methane and coal gasification, to hydrogen production process. Nuclear energy production systems provide an attractive heat source for hydrogen production. Nuclear energy is, in principle, not subjected to temperature restrictions, while the combustion temperature of fossil fuel has a maximum value that limits the working temperature for its applications (e.g., hydrogen production). Temperature limitations for nuclear power are due to the material capabilities for the fuel elements and the heat utilization system as explained below.

Higher temperature results in a higher thermal efficiency as shown in Figure C-2. For example, in a Carnot cycle, thermal efficiency is equal to $1 - T_L/T_H$, (where T_L and T_H represent temperatures of heat sources with low temperature and high temperature, respectively). Therefore, Gas-Cooled Reactors (GCRs) have been pursued to extract nuclear energy with much higher temperatures than coolant outlet temperature of other reactor types (see Figure C-10):

- LWR/HWR: around 320°C
- Carbon dioxide cooled reactors: 350-650°C
- LMFBR: 500-700°C
- HTR: 750°C in the former HTRs, 950°C in the current concepts
- VHTR: greater than 950°C.

The German AVR reached core outlet temperatures above 950°C, but did not make use of this temperature because the coolant was directly led to a steam generator operating at conventional steam temperatures of 505°C. The coolant outlet temperatures of HTRs in the actual commercial designs and the concept sets in Appendixes A and B of this report range up to 850°C. The coolant outlet temperature of the Chinese HTR-10 is 900°C, whereas the Japanese HTTR is aiming at 950°C after a full power test at 850°C.

Thus, the prototype reactors for VHTR concepts are already available and can be used for collaborative R&D. It should be noted, however, that the power density in the reactor core of the HTTR is as low as 2.5MW/m³ although the coolant outlet temperature is 950°C. The power density of the HTR-10 is 2MW/m³. In future HTRs, there are some technical uncertainties to attaining both of the coolant outlet temperature higher than 850°C and a power density of greater than about 6MW/m³, which is judged necessary for a successful commercial application.

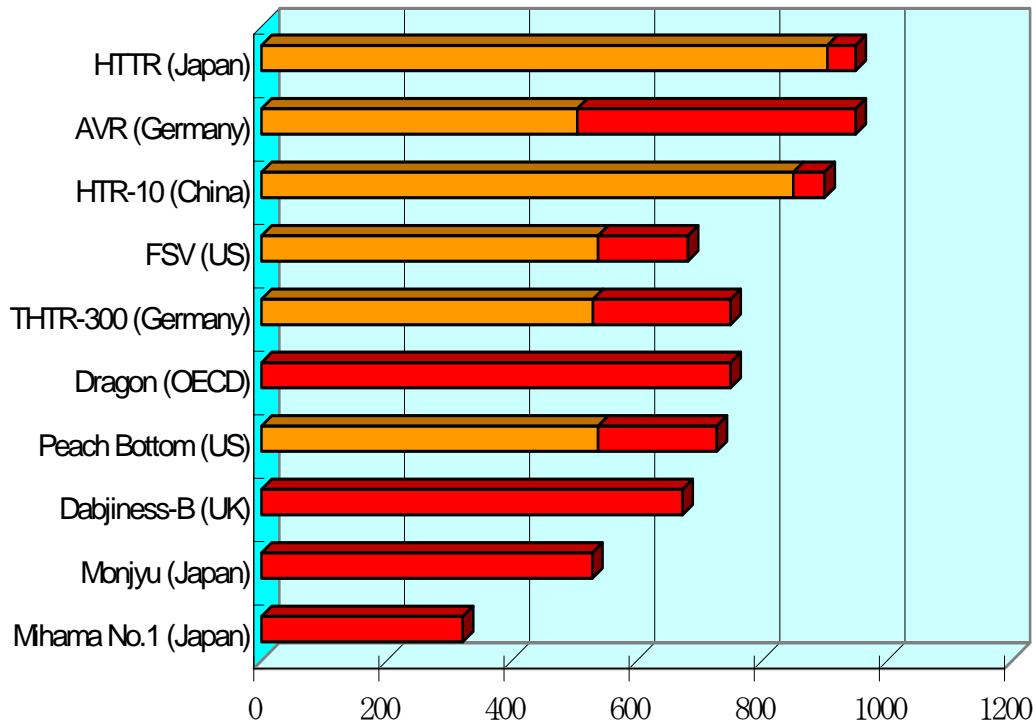

Figure C-10. Coolant outlet temperatures in various nuclear reactors

C-2.2 Concept Description

The four VHTR-relevant concepts submitted are as follows:

- (G9) - Very-High-Temperature Gas-Cooled Reactor (VHTGCR)*** for electricity generation and transportation-fuel production (e.g., hydrogen / methanol), presented by General Atomics and FRAMATOME. The VHTGCR represents a very ambitious approach towards ultra-high coolant outlet temperatures in the range of 1200 – 1500°C based on the Ultra High Temperature Reactor Experiment (UHTREX) test reactor, which had a helium outlet temperature of 1315°C. The high temperature core configuration with the excellent neutron economy allowed by high temperature BeO or graphite moderators can efficiently convert fertile materials (Th) to allow extremely deep burn cycles (approximately 8 years core lifetime). A range of fuel types and core designs can be envisioned that have the potential for both minimum initial fissile mass, relatively low enrichments, and the capability to run continuously for extended periods without refueling. Fuel and material with Very-High-Temperature capability, such as advanced fiber reinforced ceramics or zirconium carbide-coated fuels and advanced ceramic materials for pressure vessel, hot gas ducts, and recuperators, are main R&D subjects underlying the VHTR concept.

The General Atomics proposal cannot be taken as a reactor concept description, but does address the innovation potentials and motivations for enhancing the temperature range. It aims at a cost effective nuclear power system (with potentially greater than 60% efficiency), inherent safety, extended operation between refueling, minimum waste, and excellent proliferation characteristics.

- (G12) - Modular Helium Reactor (MHR)*** nuclear heat source with block type core submitted by General Atomics. The MHR concept is based on the nuclear heat supply system of the

GT-MHR directly connected to a steam reformer/steam generator unit in the primary circuit. It is an advanced, high-efficiency reactor system that can supply process heat to a broad spectrum of high-temperature applications and be used in energy-intensive, non-electric processes. It can also be equipped with an IHX, as is the case in HTTR, to broaden the application spectrum.

- (G17) - Annular Pebble Bed Reactor (APBR) for different applications, proposed by FZJ. This design essentially employs the PBMR annular core with a solid inner graphite column and a reactor vessel made up of cast iron blocks held together by multi-filament tensioned tendons. The stated advantage of this approach is that pressure vessel failure is eliminated since venting of the openings would relieve high pressures should they occur. The other advantages are that the reactor vessel can be assembled on site, thus avoiding the shipment of such a large reactor vessel, and that it can be more easily dismantled. The vessel allows for the integration of a passive cooling system to optimize the removal of the decay heat. The APBR targets a larger power size (~400-600 MWt) for different applications (electricity production, CHP, NPH, thermochemical water splitting etc.).
- (G18) – Advanced High Temperature Reactor (A-HTR) for electricity generation and hydrogen production proposed by JAERI. The A-HTR concept is based on technical data and broad experience gained from the HTTR and results of design studies of the GTHTR-300 for a gas-turbine, high-temperature reactor. The design of the GTHTR-300 has been developed in a near-term program to construct the first plant in 2010s. The GTHTR-300 has a pin-in block and annular type core, proven type reactor pressure steel, stand-alone horizontal gas-turbine/generator module, 45.5% net thermal efficiency, and 600MWt thermal power (chosen to preclude core-melt accident). The A-HTR is to be developed considering coolant outlet temperature, fuel burn-up, refueling period, and so on. In the application of the GTHTR-300 with a coolant outlet temperature of 950°C and power density of 6MW/m³, the thermal efficiency is 50% for electricity generation and hydrogen can be produced from water using a thermochemical IS process via an IHX.

The concepts described above are listed in Table C-3, and the relationship of these concepts is shown in Figure C-11.

Table C-3. Main specification of VHTR concepts

	CONCEPT			
	G-18 (A-HTR) REFERENCE	G-12 (MHR)	G-17 (APBR)	G-9 (VHTGCR)
FUEL				
- Fuel	LEU (<20%), Th, Pu	LEU (19.9%) LEU/Th, Pu/U, Pu/Th	LEU	Not specified
- Fuel Particle	SiC, ZrC			ZrC
REACTOR				
- Core Type	Pin-in Block	Multi-hole Block	Pebble	Not specified
- Thermal Power	600MW	600MW x 4 Modules	300-600MW	-
- Power Density	6MW/m ³	6.6MW/m ³		-
- Fuel Burn-up	-150GWD/ton	-120GWD/ton	120-200GWD/ton	-

Table C-3. (continued.)

	CONCEPT			
	G-18 (A-HTR) REFERENCE	G-12 (MHR)	G-17 (APBR)	G-9 (VHTGCR)
- Refueling Period	2-6 years			-
- Coolant Conditions		Outlet: -1000 C		
- Inlet/Outlet Temperature.	560/850°C → 630/950°C		250/(700-1000) °C	Outlet: 1200-1500°C
- Outlet Pressure	-6.8MPa		5-8MPa	-
APPLICATION				
- Electricity Generation		None	Steam, Gas, Co-generation	
- Cycle Type	Direct cycle	-		Direct Cycle
- Thermal Efficiency	-50%	-		-60%
- Electric Power	300MW	-		
- Nuclear Process Heat				
- Cycle Type	Indirect	Direct	Direct/Indirect	
- Application	H ₂ production (IS Process, Steam reforming)	Heavy oil, Tar sands recovery, Coal liquefaction, Coal gasification, Steel, Aluminum mill process CH ₃ OH production, H ₂ production by steam reforming and thermochemical process	Heavy oil, Tar sands recovery, Coal liquefaction, Coal gasification, Steel, Aluminum mill process CH ₃ OH production, H ₂ production by steam reforming and thermochemical process	H ₂ production, Coal liquefaction, Coal gasification
FUEL CYCLE	Once-through or Interim Storage & Reprocessing	Once-through	Once-through	not specified

The G-18 (A-HTR) concept is selected as a reference for the VHTR concept set. There are limited conceptual differences among the G-12 (MHR), G-17 (APBR) and G-18 (A-HTR), except for the reactor core type and cycle type of heat application (like direct/indirect cycle), as indicated in Table C-3, namely with or without IHX. On the other hand, the G-9 (VHTGCR) is not a concept of a total reactor system, but a proposal for Very-High-Temperature application based on the G-10 (GT-MHR) reference concept of the prismatic modular reactor (PMR) concept set. G-9 includes considerable R&D on fuel and material with capability for very high temperature. The G-12 concept is dedicated to nuclear heat application and is also based on the G-10, except for the energy conversion applications. The coolant outlet temperatures of the G-17 range from 700°C to 1000 C. Accordingly, the reference concept G-18 (A-HTR), as described herein, is not a single concept but represents the entire range of VHTR concepts, as graphically depicted in Figure C-11.

This appendix refers not only to the submitted reactor concept proposals but also to the open literature on NPH applications. These include International Atomic Energy Agency TECDOCs 5-8, former VHTR concepts (e.g., the Japanese NSS-project, the German PNP project, HTR-Module for NPH, etc.), and ongoing projects of the HTTR and the HTR-10. The Japanese HTTR and the Chinese HTR-10, represent real technological milestones with regard to the demonstration of the feasibility of NPH at an intermediate level (900-950°C) on the way to demonstrating very high coolant outlet temperatures up to 1500°C.

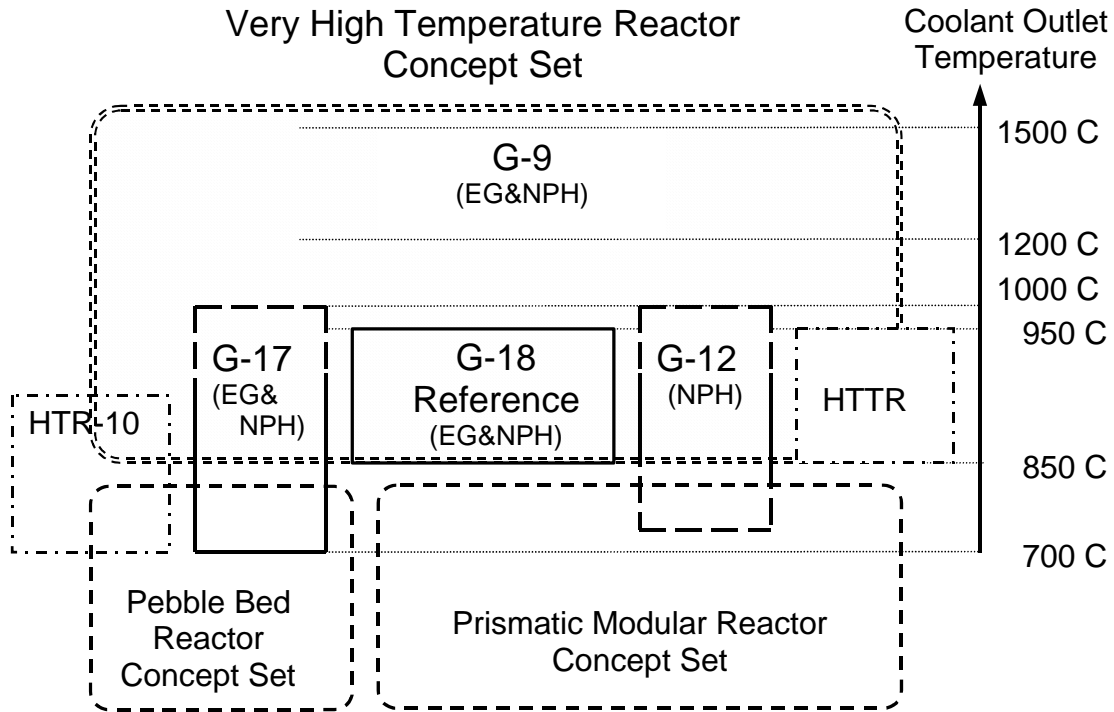

Figure C-11. Relationship between VHTR concepts submitted and ongoing HTRs.

C-2.3 Reference Concept Description

The G-18 concept (A-HTR) is helium, gas-cooled and graphite-moderated thermal reactor. The fuel is up to 20% low enriched uranium (LEU) with maximum burnup of 150 GWD/ton. The core is refueled only once every two to six years based on several potential refueling schemes presently under detail evaluation. The reactor is inherently safe due to negative temperature coefficient and the capability of passive decay heat removal from the core through the reactor pressure vessel wall to the reactor cavity cooling system. The annular core configuration was adopted to achieve maximum power rating and still permit passive core heat removal while maintaining the coated particle maximum anticipated fuel temperature below 1600°C for SiC TRISO or 1800°C for ZrC TRISO during a worst case accident condition of total loss of coolant and loss of flow, thus assuring that fuel integrity is not degraded.

The major application advantages of the A-HTR would be (1) further increasing the efficiency of the direct-cycle, gas-turbine system and (2) heat application for hydrogen production. An increase in thermal efficiency by 2.5% is attainable when the coolant outlet temperature is raised from 850°C to 950°C (the reference coolant outlet temperature for HTTR). The thermodynamic cycle and the aerodynamic designs of cycle and gas turbine as well as system structural design would remain largely unchanged in comparison with the GTHTR-300, which is the base design of the A-HTR. The addition of

single-stage cycle intercooling would have the potential to increase thermal efficiency by another 2 to 3%, depending on the extent of design changes desired.

The plant for electricity generation consists mainly of three subsystem modules: the 600MWt prismatic core reactor, the stand-alone gas turbine generator, and a heat exchanger unit, as shown in Figure C-12. The three modules can be factory built and site erected essentially in parallel. Portioning into subsystems can also greatly simplify maintenance.

The nuclear heat supplied from the A-HTR is applicable not only to electricity generation but also to hydrogen production by steam reforming of methane or water splitting with the thermochemical IS process (see Figure C-13). The steam reforming process is a mature technology in the petrochemical industries, but no heat application process connected with a HTR has yet been realized. The thermochemical IS process is under development to be applicable for use as an NPH source. When the nuclear heat is provided to the hydrogen production process, it is transferred from the reactor core to the secondary helium coolant through an IHX. High reliability of the boundary in the IHX between the primary and the secondary helium coolant is required to design a heat application process with non-nuclear standards. The heat application facilities must be designed with nuclear standards if direct cycle without IHX is adopted because the heat application process would be connected to the primary helium coolant loop.

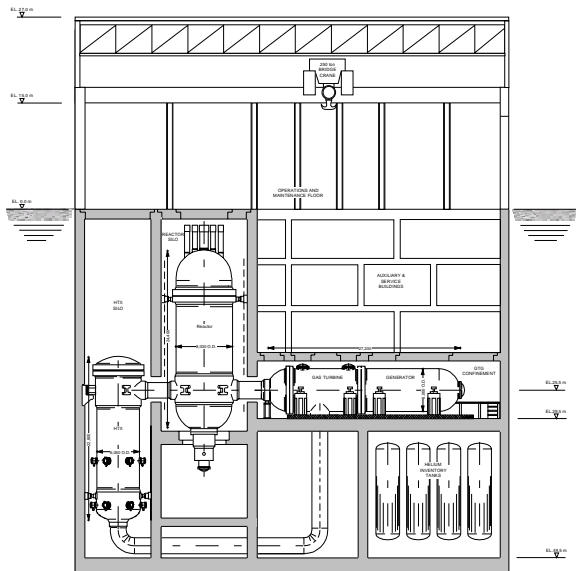

Figure C-12 Schematic drawing of the A-HTR with gas turbine system

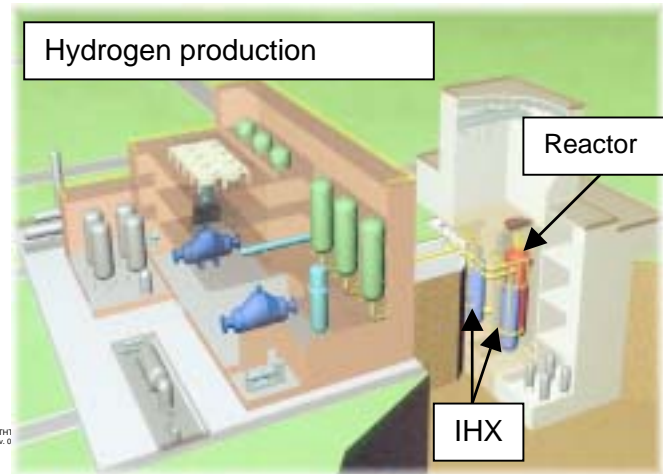

Figure C-13 Schematic view of the A-HTR with hydrogen production system

The G-9 (VHTGCR) concept proposal can be superimposed on any of concepts, such as G-12 (MHR), G-17 (APBR), and G-18 (A-HTR). Around 1000°C coolant outlet temperature in the G-12, G-17 and G-18 can be regarded as the near-term target of the VHTR, and a combination concept of the G-9 and one of the VHTR concepts will be attained. R&D, such as fuel and plant material development necessary for the combination concept, should be performed in parallel with R&D for the features represented by concepts G-12, G-17, and G-18. Even intermediate results of fuel and material R&D could contribute to the safety and long-life design capability of these concepts.

In summary, a VHTR system for process heat applications could significantly enlarge the nuclear option as a solution to future energy supply beyond dedicated electricity generation (e.g., for process heat and thermochemical hydrogen production). The increased operational temperatures can also improve the efficiency of electrical power generation, reducing rejected heat cooling requirements, and improving fuel utilization.

C-3 Potential of the Concept Set for Meeting Generation IV Goals

C-3.1 Evaluation against Criteria/Metrics

The motivation for very high operational temperatures is threefold:

1. Increasing the thermal efficiency of energy conversion for electricity production and nuclear heat processes, thus reducing fuel usage and fission product waste generation
2. The potential for new applications requiring high temperature levels (e.g., hydrogen production, coal gasification, metallurgic processes, cement manufacture, and glass manufacture) for sustainability
3. The potential for design compaction of the reactor core for improved economics, safety, and reliability.

These potentials are not for a single concept but a common future option for all HTR designs, with the extent of these benefits further realized for the VHTR assuming the required fuel and plant materials development. These potentials support the Generation-IV goals, as described below.

Evaluation results of the G-18 (A-HTR) reference concept set are almost the same as the G17 and G12 concepts, which are similar to the PBR and PPMR reference concepts evaluated in Appendixes A and B, respectively. Accordingly, the potential evaluation presented here is made for the G-18 reference concept merged into the proposal of the G-9 concept to make the advantages of the VHTR clear. Evaluation results are shown in Table C-4.

C-3.1.1 Sustainability.

- **Sustainability 1: Long Term Fuel Supply.** The fuel utilization of the G-18 reference concept is 180 ton of natural uranium/GWe-year, or 7-8.4 ton of enriched uranium/GWe/year.
 - Because graphite in fuel particles and fuel elements are stable against irradiation-induced damage and chemical attack under helium gas conditions, this characteristic permits burnups of 120 to 150GWD/ton with LEU fuel without recycling.
 - Fossil fuel is not consumed in the thermochemical IS process for hydrogen production from water.
- **Sustainability 2: Waste Management.** The waste mass of the G-18 reference concept is 5Mton/GWe/year. The G-9 concept, with a projected thermal efficiency of $\geq 60\%$, provides a very large reduction of high-level wastes (HLW). VHTR reactor fuels that consist of SiC-coated or ZrC-coated particles present a nearly ideal final waste form.
 - High thermal efficiency results in significant reduction of HLW on a per unit energy basis.

- Spent fuel elements are a nearly ideal final waste form that requires no further processing or additional barriers (e.g., overpack).
- No chemical material is produced as waste in the thermochemical IS process because the process is a completely closed cycle.
- Sustainability 3: Non-proliferation. Proliferation concerns will be drastically reduced with VHTR core designs that have initially low fissile inventories and produce lower actinide mass and actinide isotopic ratios unattractive for weapons.
 - Highly dilute fuel form
 - Controlled, periodic off-line refueling.

C-3.1.2 Safety and Reliability.

- Safety and Reliability 1: Excel in Safety and Reliability, and Safety and Reliability 2: Low Likelihood of Core Damage. Peak fuel temperatures do not occur for several days after loss of coolant because of the low core power and large heat capacity of graphite core components. SiC-coated fuel can operate in excess of 1600°C. ZrC-coated fuel, specifically optimized for high temperature performance, is expected to operate in excess of 1800°C without loss of particle coating integrity but has yet to be developed and qualified. The VHTR ZrC-coated particle fuel and a Beryllium or Graphite ceramic core can operate well in excess of 1600°C without structural damage. The reactor system could be designed (e.g., ceramic materials, annular geometry, etc.) to facilitate rapid recovery and restart, even after postulating a loss of flow or loss of coolant transient.
 - ZrC-coated particle fuel can operate up to 1800°F without loss of integrity. The core is designed to passively maintain fuel temperatures below this level for all postulated events.
 - The helium coolant is neutronically inert and is not subject to any phase change.
 - Strongly negative temperature coefficient of reactivity from ambient temperature to bounding accident temperatures. Coupled with very large core temperature margins, this attribute provides passive response to anticipated transients without scram.
- Safety and Reliability 3: No Offsite Emergency Response. The VHTR plant is designed to meet Environmental Protection Agency Protection Action Guides at 425-m Exclusion Area Boundary (EAB) for all events with frequency of $>5 \times 10^{-7}$ /year (i.e., LPZ located at EAB). Additionally, the plant is designed in such a way that no external accident management measures (dislocation, food restrictions) have to be undertaken outside the plant fence.

C-3.1.3 Economics

- Economics 1: Life Cycle Cost Advantage. Detailed cost evaluations of the base VHTR plant are expected to show that it is competitive with all other systems for new electricity generation capacity because of thermal efficiencies greater than 60%. A modular design approach allows for incremental addition of capacity to minimize up-front capital costs.

- *Economics 2: Comparable Financial Risk*. Maximum utilization of technology developed by the industry (gas turbines, heat exchangers, ceramic material development) and for jet engines will reduce financial risk significantly. Modular designs minimize the construction risk on a per reactor basis.

For Economics 1 and 2:

- The system uses helium coolant at high temperature to drive a direct-cycle gas turbine with an overall electrical generation efficiency of up to 50%.
- Simplified design of the plant system and maintainability makes for low operation cost per electric power generation.
- The plant maximizes utilization of the HTTR R&D results, proven HTGR technology, industrial gas-turbine/heat exchanger technologies, and chemical plant technologies.
- Confirmatory technology development programs are needed (e.g., fuel, magnetic bearings, heat exchangers, etc.).

C-3.2 Summary of Concept Potential (Strength & Weaknesses)

The increase from 850°C to 950°C coolant outlet temperature for the VHTR compared to other high temperature gas reactor concepts enables the thermal efficiency of electricity generation to increase from 46% to 50%, and enables hydrogen production using steam reforming of methane and thermochemical IS processes. Such electricity generation with high thermal efficiency and hydrogen production could lead to large improvements in the sustainability and economy goals, thus keeping safety comparable to other gas reactor concepts with little R&D risk.

Further R&D on fuel and plant materials with high temperature capability is required to make coolant outlet temperature higher than 1000°C. Achieving a coolant outlet temperature higher than 1000°C can lead to progress for the goals of sustainability, economy, and safety. For example, a thermal efficiency of 60% could be attained with a coolant outlet temperature of a little over 1200°C, and at this coolant outlet temperature, methane direct pyrolysis and coal gasification could be achieved. Recently, material development is rapidly proceeding in other fields, such as for automobile engines and combustion gas turbines. These developments will contribute to reducing the development risk for a VHTR system.

It is concluded that the VHTR concept set has the following potential attributes for Generation IV application:

- High efficiency by increased temperature
- Reduced generation of highly radioactive and long-lived radiotoxic waste
- Versatile application for electricity production and process heat (e.g., hydrogen production)
- Improved safety by increasing high temperature margins
- Attractive economics due to high efficiency, lower overall waste generation, and high power density

- Improved neutron economy (e.g., BeO reflector, minimal initial fissile mass)
- Ultra-high burn-up cycles and extended refueling periods that can improve proliferation resistance.

C-4 Technical Uncertainties (R&D Needs)

Development of the VHTR concept has to be seen in the context of the general HTR-related R&D programs throughout the world. Cross-fertilization will allow mutual use of R&D results for all types of HTR because the NHSS will be rather similar for different applications. Enhanced operational temperatures are already possible with the available fuel, as has been shown by several past projects. These include the UHTREX at Los Alamos in the 1960s, which achieved the highest temperature; former projects on NPH in Japan and Germany (like the PNP-500 project); and ongoing projects on the Japanese HTTR and the Chinese HTR-10. The UHTREX core was fueled with pyrolysis carbon coated UC₂ fuel particles and had a helium outlet temperature of 1315°C. But the reduced margins to the maximum allowable temperature in accident conditions (about 1600°C for SiC) may require further reduction of power densities or total power of VHTR plants to protect the integrity of the coated particles. The temperature capability of the coated particles in a core heat-up accident is also a function of the burn-up and has to be carefully studied when improving the fuel design, matching at the same time higher allowable temperatures and higher burn-up requirements. The consequences of higher temperatures on corrosive attack (e.g., air ingress, water ingress) on the graphite structures and the fuel also have to be taken into account by accident analyses and development of appropriate precautions (e.g., oxidation protection for ZrC fuel being stable up to 1800°C). The analytical modeling of the fuel and of accident sequences will have to be further improved to match with more stringent safety requirements in an industrial environment and highly populated areas, as can be assumed for CHP and NPH applications.

The main temperature limitation for VHTR is given by the use of metallic components for the heat utilization or power conversion systems. At 950°C, the lifetime of available high temperature alloys will be reduced. As a consequence, components being exposed to high temperatures may have to be replaced every 15-20 years if no better materials can be qualified. Ease of replacement will be a challenge for the design (e.g., modular arrangements), whereas the improvement of high temperature alloys and their qualification under VHTR conditions remains a medium to long-term R&D task. New material choices like compound materials, fiber reinforced ceramics, or fully ceramic components may lead to a breakthrough for significant operational temperature increase above 1000 C.

Graphite, being an essential structural material for HTR, is more sensitive to irradiation with fast neutrons at elevated temperatures. Materials being discussed for fusion blankets, such as special fiber reinforced SiC, may be an alternative, at least in critical zones like the non-exchangeable reflector of pebble bed reactors. Close collaboration with fusion projects may create mutual synergies.

Another approach to keep within accident temperature limits could be an improved decay heat removal strategy. This could be done by additional cooling of the central column of annular reactor cores and/or enhanced heat transfer from the pressure vessel, as proposed in the APBR design, by using a pre-stressed cast iron pressure vessel with integrated cooling systems. Passively operating heat pipes instead of conventional cooling systems might also show advantages as they reduce heat losses in operational conditions and work very efficiently above certain temperatures.

In application systems of nuclear heat, following the two different approaches on direct or indirect cycles for gas turbines and process heat applications, a set of components will have to be qualified for nuclear service conditions. In case of an indirect cycle, R&D programs will have to address hot gas ducts and the IHX. Much is known at the 10 MW scale based on the former German and Japanese NPH

programs. This has to be revisited considering the current state-of-the-art and the requirements for modular reactors that have one loop, resulting in significant size of the IHX when compared to former multi-loop designs. Since the IHX will be the main barrier to the ‘conventional’ secondary cycle, it will be essential to test it at large scale under normal and abnormal conditions. Special valves operating at high temperatures will be necessary as a second line of defense, which will also require development. The available test reactors HTR-10 and HTTR will provide additional knowledge that should be shared via common research programs. New, more compact IHX designs may be of economic interest and should be the subject of further R&D. The size and cost of the IHX is dependant on the allowable temperature difference between the primary and secondary side. It is obvious that any progress to raise temperatures across the IHX for a given temperature on the secondary side will result in significant economic benefits.

Nuclear Process Heat components for direct cycles, such as steam reformers, superheaters, and heat exchangers, impose much higher safety requirements that may counterbalance the cost for indirect cycles. This is especially true when considering the danger of radioactive contamination of the products. Special coatings on the surfaces could be necessary to prevent fission product or tritium migration through the walls. No residual contamination of the product will be essential for public and industrial acceptance of the process. In this respect, it may be prudent to for NPH applications to initially use indirect cycles and keep direct-cycle NPH applications as a more long-term option for further simplification and system optimization. As the problem of product contamination does not exist for direct-cycle gas turbines, such a choice between direct or indirect cycles will be mainly governed by economics and maintenance aspects.

Hot gas ducts and component insulation have to be qualified for the very high temperatures and for accident loads associated with internal shock waves when assuming deblading of the turbine. Problems also arise from connection of the ceramic structures with the metallic parts of the hot gas ducts, bends, and compensators. Large diameter insulation of high-temperature components and seals between moving parts require design and development attention, including preventing self-welding under helium and increased temperatures over long-time operational loads.

Both gas turbine technology and other heat applications can utilize conventional technology for the most part. Nevertheless, specific R&D will be necessary to adopt the components and processes to nuclear use. Steam reforming presents a crucial process for many applications in oil refineries and chemical plants, has already been demonstrated at a 10-MW scale in non-nuclear test facilities in Germany, and will soon be subject of testing in the secondary circuit of HTTR. Challenges in extrapolation to the 100-MW scale will have to be identified as a basis for further improvements. Thermochemical water splitting processes (e.g., the IS-process, hot electrolysis, etc.) have to be assessed with regard to their feasibility in large scale. Significant work at a partial full scale is underway in Japan, having completed investigations on the IS-process in a laboratory scale. International collaboration should be encouraged on development needs such as components operating in aggressive media, high temperatures and large pressure differences. The chemical engineering of the processes still has to be optimized. Specific safety and licensing aspects have to deal with regarding gas explosions and product contamination by tritium.

In summary, both pebble and block fuel types of reactor cores can equally be used in the VHTR range. Technical uncertainties for the VHTR concept set involve the technical uncertainties for either the PBR or PMR concept set, as follows.

- Reactor

- Development of fuel with high temperature capability and high burnup
- Development of method for decreasing U-235 in fuel after burnup

- Development of recycling or adopt once-through technology
- Development and qualification of irradiation-resistant graphite
- Development of heat transfer augmentation (e.g., heat pipes) for decay heat removal
- Development of additional safety standards:
 1. To potentially eliminate requirements for an Emergency Core Cooling System (ECCS) and Containment vessel
 2. To consider reducing the design and quality requirements for the primary boundary in consideration of the intended fuel integrity.
- Electricity generation using direct cycle turbines
 - Development of magnetic bearings
 - Demonstration of gas turbine systems and compressors
 - Demonstration of rotating seals to take the generator out of the primary circuit
 - Demonstration of high-speed turbo-compressors, generators, and high frequency alternators
 - Development of compact recuperator, flexible coupling, etc.
- Heat Application
 - Demonstration of connection of the nuclear heat application process to an HTGR in direct/indirect systems
 - Development of compact IHXs, high-temperature isolation valves, hot gas ducts, etc.
 - Development of a water splitting method to produce hydrogen, such as the thermochemical process
 - Development of methods to increase efficiency to produce hydrogen
 - Development of material with resistance to corrosion and structural failure at high-temperature
 - Development of a method to decrease reaction temperature

Specific technical uncertainties for the VHTR concept set are the advanced fuel and material with high temperature capability and heat transfer augmentation for decay heat removal. Fuel and plant material suggest considerable improvements in the fuel design and in material properties to withstand high operational temperatures over several hundred thousand hours and avoid replacement of components during the lifetime of the plant. High temperature alloys, fiber reinforced ceramics or compound materials, as well as ZrC coatings of the fuel, are promising candidates to overcome current temperature limitations. ZrC coatings are expected withstand temperatures up to 1800°C during severe accidents,

while the limitation temperature for SiC coatings is about 1600°C. Thus, ZrC provides excellent characteristics in thermal resistance, but has increased potential for oxidation.

C-5 Technical Innovations (design improvements)

Preserving fuel integrity against fission product release up to 1800°C during accident conditions would represent an important innovation for other HTRs as well. This would enhance safety due to larger thermal margins, improve the economics of scale for HTRs (since larger core sizes could be practical while maintaining the same safety advantage of no fuel failure under accident conditions), and provide the capability for intermediate operating temperature increase to improve thermal efficiency. Higher temperature capabilities of metallic and ceramic materials enhance safety margins, improve design lifetime, and supports potential new fields of nuclear applications. In addition, technology for high-temperature materials, such as high performance ceramics, fiber-reinforced materials, and compounds, addresses needs for other reactor types, such as Fast Gas-Cooled Reactors, LMR, and molten salt reactors.

Heat exchanger technology is key to supporting transfer of nuclear heat to application processes for indirect heat application and to supporting conversion of nuclear heat into electricity in direct gas turbine system cycles. Compact IHXs and recuperators for use at high temperature require materials with high temperature resistance, structural strength, and high reliability. The high temperature heat source enables various hydrogen production methods, such as direct decomposition of methane, and can make the chemical reactor more compact by increased chemical reaction rates.

Providing the capability for nuclear energy to be used for other heat energy applications beyond electric power production would be a revolutionary step in enlarging the market potential beyond the present level of deployment of nuclear plants. Such capabilities would improve utilization of limited fossil energy reserves, such as processing heavy crude oil, and would support the first steps towards a 'Hydrogen Economy' to reduce climate affecting gas emissions and support the continually increasing demand for energy in the world. It seems essential to make extended use of the existing test reactors (HTR-10 and HTTR) within international R&D networks and to persuade potential users of the feasibility and economics of NPH.

C-6 Statement of Overall Concept Potential Versus R&D Risk

The operational temperature of the fuel is not the limiting factor and would allow for operational coolant gas temperatures well above 1000 C. The main motivation to enhance the temperature capability of the fuel beyond 1600°C is enhanced safety (e.g., larger margin to preclude unacceptable fission product release under accident conditions) and improved economics. As a result, ZrC coatings could be an attractive alternative to the current design TRISO fuel particles using SiC. In this respect, it should not be forgotten that the maximum allowable temperatures for the fuel are also a function of the burn-up. Thus, improved capability in this area might also be utilized by increasing burn-up and only slightly increasing the maximum temperatures.

The coating of the fuel particles also has to be evaluated with regard to its resistance to accidents under air and/or water ingress, especially for high temperatures. Additional protection against corrosion on the surface of the fuel element could be a precondition for the application of ZrC. It is also desirable to investigate the leaching resistance of this VHTR fuel under final disposal conditions. It may be possible to make use of the coated particles, and additional coatings, both for safety enhancements and as a conditioning for the final waste form for disposal, which would provide attractive economic benefits.

Using very high temperatures requires components that are capable of withstanding these temperatures, preferably over the full lifetime of the plant, to avoid downtime and cost for component

replacement and additional non-fuel waste. On the basis of a 60-year lifetime, current metallic components are presently still restricted to 900-950°C and could be expected to improve only incrementally. Technological breakthroughs should be pursued via high performance ceramics, fiber-reinforced materials, and compounds. These types of materials have to be qualified for HTR conditions. Synergies can be taken from other conventional developments or even from fusion having similar challenges for the walls facing the plasma.

Very-High-Temperature NPH applications for HTR exist in the following areas:

- Hydrogen generation via thermochemical water splitting or high temperature electrolysis
- Methanol synthesis
- Refinery processes
- Coal gasification and liquefaction
- Direct reduction of ore
- Aluminum oxide production.

These areas represent a huge market potential in addition to high efficiency electricity generation when enhancing the operational temperatures beyond 950°C. With this background it appears as justified to launch collaborative R&D on VHTR technology.

C-7 Screening for Potential Scoresheet

The potential evaluation of the reference concept of G-18 (A-HTR) is similar to the PMR concept set described in Appendix B. Therefore, the reference concept and superimposing the proposed G-9 (VHTGCR) is evaluated here. Very high temperatures achieved by fuel and materials with Very-High-Temperature resistance result in the following advantages and disadvantages:

Advantages

- High coolant outlet temperature
- High Power density
- Enhancement of lifetime of components
- Enhancement of safety margins
- Increased fuel burnup.

Disadvantage

- Less oxidation resistance of ZrC coating compared to SiC coating.

Table C-4 shows the Scoresheet for the VHTR concept.

C-8 References

1. Forsberg, C.W, and K.L. Peddicord, "Hydrogen Production as a Major Nuclear Energy Application," *Nuclear News*, ANS, September 2001
2. International Atomic Energy Agency, "Current status and future development of modular high temperature reactors," IAEA-TECDOC-1198
3. International Atomic Energy Agency, "High temperature applications of nuclear energy," IAEA-TECDOC-761
4. International Atomic Energy Agency, "Hydrogen as an energy carrier and 1st production by nuclear power," IAEA-TECDOC-1085
5. International Atomic Energy Agency, "Nuclear heat applications: Design aspects and operating experience," IAEA-TECDOC 1056
6. Shimizu, S., et al., "A Study on The Thermochemical I-S Process," OECD-NEA Nuclear Science Committee, First Information Exchange Meeting on Nuclear Production of Hydrogen, 2-3 October, Paris, France, pp. 129-136 (2000).
7. Shiozawa, S., et al., "Present Status of JAERI's R&D on Hydrogen Production Systems in HTGR," OECD-NEA Nuclear Science Committee, First Information Exchange Meeting on Nuclear Production of Hydrogen, 2-3 October, Paris, France, pp. 57-69 (2000).
8. "UHTREX: Alive and Running with Coolant at 2400°F," *Nuclear News* 12 (31) (1969) 31-32.
9. Yan, X. et al., "Design Innovation in GTHTTR 300 Gas Turbine High Temperature Reactor," Proceedings of ICONE 8, 2-6 April, Baltimore, MD US (2000).





Table C-4. Screening for Potential Scoresheet





Concept Name: A-HTR









Summary Evaluation : X Retain Reject



Comparison to Reference Much Worse Worse Similar Better Much Better
 -- - = + ++

Sustainability 1 Effective Resource Utilization					<ul style="list-style-type: none"> - Because graphite in fuel particles and fuel elements are stable against irradiation-induced damage and chemical attack under helium gas condition, this characteristic permits burnups of 120,000 to 150GWD/ton with LEU fuel without recycle and reprocessing. - Fossil fuel is not consumed in the thermochemical IS process for hydrogen production from water.
SU1-1 : Fuel utilization					<ul style="list-style-type: none"> - High thermal efficiency can decrease fuel amount used per energy product.
SU1-2 : Fuel cycle impact on environment					
SU1-3 : Use of other resources					
Sustainability 2 Efficient Waste Management					<ul style="list-style-type: none"> - High thermal efficiency results in significant reduction of high-level wastes on a per unit energy basis. - Spent fuel elements are a nearly ideal final waste form that requires no further processing or additional barriers (e.g., overpack). - No chemical material is produced as waste disposal in the thermochemical IS process because the process is completely closed cycle.
SU2-1 : Waste minimization					
SU2-2 : Environmental impact					<ul style="list-style-type: none"> - High thermal efficiency can decrease heat amount released to environment. - Hydrogen can decrease environmental impact as alternative energy of fossil fuel.
SU2-3 : Stewardship burden					

Sustainability 3 High Proliferation Resistance					<ul style="list-style-type: none"> - Highly dilute fuel form - Controlled, periodic off-line refueling.
SU3-1 : Material life cycle vulnerability					
SU3-2 : Application of extrinsic barriers					
SU3-3 : Unique characteristics					<ul style="list-style-type: none"> - High temperature enlarge potential of application of VHTR not only electricity generation but also various nuclear heat applications such as glass, cement and iron manufactures in very high temperatures of 1000-1500°C.

Safety and Reliability 1 Superior Safety and Reliability					<ul style="list-style-type: none"> - ZrC coated particle fuel can operate up to 1800°C without loss of integrity. The core is designed to passively maintain fuel temperatures below this level for all postulated events. - Peak fuel temperatures do not occur for several days after loss of coolant because of low core power density and large heat capacity of graphite core components. - The helium coolant is neutronically inert and is not subject to any phase change. - Strongly negative temperature coefficient of reactivity from ambient temperature to bounding accident temperatures. Coupled with very large core temperature margins, this attribute provides passive response to anticipated transients without scram.
SR1-1 : Public/worker-routine exposures					
SR1-2 : Worker safety-accidents					
SR1-3 : Reliability					<ul style="list-style-type: none"> - Fuel and material with high temperature resistance can provide enough safety margin.

Safety and Reliability 2 Low Probability of Reactor Core Damage					- ZrC coated particle fuel and ceramic core can operate up to 1800°C without loss of integrity.
SR2-1 : Facility state transparency					
SR2-2 : System model uncertainty					- Irradiation data of fuel and material with high temperature resistance are not enough to design the system integrity.
SR2-3 : Unique characteristics					
Safety and Reliability 3 Elimination of Need for Offsite Emergency Response					- The plant is designed in a way that no external accident management measures (dislocation, food restrictions) have to be undertaken outside the plant fence.
SR3-1 : Robust mitigation features					
SR3-2 : Damage/dose understood					
SR3-3 : No additional individual risk					
SR3-4 : Comparable societal risk					

Economics 1 & 2 Clear Life-Cycle Cost Advantage Financial Risk Comparable to Other Energy Projects					<ul style="list-style-type: none"> - The system uses helium coolant at high temperature to drive a direct cycle gas turbine with an overall electrical generation efficiency of up to 50%. - Simplified design of the plant system, cycles process and maintainability makes the low operation cost per electric power generation. - Maximum utilization of the HTTR R&D results, proven HTGR technology, industrial gas-turbine/heat exchanger technologies and chemical plant technologies. - Confirmatory technology development programs planned (e.g., fuel, magnetic bearings, heat exchangers, etc.) prior to plant construction and commissioning.
EC-1 : Low capital costs					- High thermal efficiency can decrease capital costs.
EC-2 : Low financial costs					

EC-3 : Low production costs		↔		<ul style="list-style-type: none"> - High thermal efficiency can lower the cost of products. - If electricity generation plants of VHTRs could economically compete against other ones, heat cost of VHTR would be inexpensive comparing with other plants.
EC-4 : Low development costs		↔		<ul style="list-style-type: none"> - R&D of fuel and material with high temperature resistance requires development cost more than that of the concept sets described in Appendixes A and B., But development cost for material would not be so much because R&D costs can be shared among various kinds of industry such as car companies and gas turbine maker.
EC-5 : High profitability			↔	

APPENDIX D

**Gas-Cooled Fast Reactor (GFR) Systems
Summary Report**

CONTENTS

ACRONYMS.....	123
D-1. INTRODUCTION.....	127
D-2. CONCEPT SET DESCRIPTION.....	127
D-3. THE MODULAR, HELIUM-COOLED FAST NUCLEAR ENERGY SYSTEM (CONCEPT G7)	128
D-3.1 Main Design Features	129
D-3.2 Innovative Technologies	131
D-4. POTENTIAL OF THE MODULAR HELIUM-COOLED FAST NUCLEAR ENERGY SYSTEM” TO MEET GENERATION IV GOALS	131
D-4.1 Sustainability.....	131
D-4.2 Safety and Reliability Goals.....	133
D-4.3 Economics.....	135
D-5. REVIEW OF SPECIFIC FEATURES OF CANDIDATE CONCEPTS RELEVANT TO THE GAS-COOLED FAST REACTORS CONCEPT SET	136
D-5.1 Modular, Fast Gas-cooled Reactor–Gas Turbine Cycle (Concept G2).....	136
D-5.2 Gas-cooled Oxide Fuel Fast Reactor System with Dry Recycling Fuel Cycle (Concept G5).....	138
D-5.3 Enhanced Gas-cooled Reactor (EGCR) (Concept G16)	140
D-6. POTENTIAL OF THE CONCEPT SET FOR MEETING GENERATION IV GOALS	142
D-6.1 Evaluation against Criteria / Metrics.....	142
D-6.2 Summary of Concept Set Potential	143
D-7. TECHNICAL MATURITY OF CONCEPT SET AND TECHNOLOGY POTENTIAL VERSUS R&D RISK	143
D-8. REFERENCES	144

Figures

D-1. Schematic diagram of possible core layout with inner reflector for a modular, helium-cooled fast nuclear energy system with ceramics fuel (cercer), or ceramics/metal (cermet) or composite metal (metmet) as back-up solutions.	130
D-2. Schematic diagram of possible ceramics fuel concept, core design features without inner reflector, and general architecture of the reactor vessel for a modular, helium-cooled fast nuclear energy system.	130

Tables

D-1. Screening for potential score sheet of the Modular helium cooled fast nuclear energy system	145
--	-----

ACRONYMS

AECL	Atomic Energy of Canada, LTD.
AGR	Advanced Gas-cooled Reactor
ALWR	Advanced Light Water Reactor
EGCR	Enhanced Gas-Cooled Reactor
GCFR	Gas-Cooled Fast Reactor (marketed by General Atomics)
GFR	Gas-Cooled Fast Reactor
GT-MHR	Gas Turbine – Modular Helium Reactor
HEN-MHR	High-Energy Neutron Spectrum Modular Helium Reactor
KAERI	Korean Atomic Energy Research Institute
LMFBR	Liquid Metal-cooled Fast Breeder Reactor
LMFR	liquid metal-cooled fast reactor
LOCA	loss of coolant accident
LOFA	loss of fluid accident
LWR	light water reactor
PWR	pressurized water reactor
R&D	research and development
WPu	weapons plutonium

Appendix D

Gas-Cooled Fast Reactor (GFR) Concepts Summary Report

D-1. Introduction

Gas-cooled fast reactors (GFRs) have unique capabilities for an effective and flexible utilization of fissile and fertile fuel reserves. The development of fast reactors using liquid sodium as coolant has established the system's viability. However, the industrial development of liquid metal-cooled fast reactor (LMFR) designs has languished, as the need for efficient fuel utilization is not pressing today, and fast reactors still need to demonstrate their potential for high reliability and economic advantage over established alternative nuclear systems.

The choice of coolant for fast reactors may be reconsidered in light of changes to the requirements and priorities that initially led to sodium as the preferred coolant. The scarcity of plutonium, leading to the adoption of very high power density cores to minimize fissile inventory, and high breeding gain to allow the rapid introduction of fast reactors into the nuclear park, is no longer a crucial issue. On the other hand, today's requirements put a strong emphasis on improving plant inspectability and maintainability, eliminating chemical hazards associated with the coolant, and reducing major safety concerns, such as the coolant void effect.

Based on the early work of the Gulf General Atomic Corporation on the Gas-Cooled Fast-Breeder Reactor (GCFR) project and equivalent work in Europe, gas may be reconsidered as a fast reactor coolant in the present context. To build on updated technologies of current gas-cooled modular reactor projects, and to make the best possible use of other advanced technologies available today, GFR systems may become an important future option. A breeding capability near unity may be considered as sufficient in the intermediate term, with enough flexibility to allow for synergistic fuel cycles with light water reactors (LWRs) to manage growing plutonium stockpiles and possibly transmute minor actinides and long-lived fission products.

A new generation of GFRs with a direct Brayton cycle has the potential to combine the advantages of high sustainability, high temperature, and economic competitiveness, while making nuclear energy benefit from the most efficient conversion technology today. It also has the potential for preserving most of the attractive safety features of thermal gas-cooled reactors, and the advantages of a closed and integrated fuel cycle for minimizing the needs for mining, transports of nuclear materials, and proliferation risks. These outstanding features call for the development of high-performance refractory fuels, high heat resisting materials, and simplified and compact fuel cycle processes (treatment and re-fabrication).

D-2. Concept Set Description

The concept-set of GFRs comprises four individual concepts:

- Concept G2. Modular, Fast Gas-Cooled Reactor – Gas Turbine Cycle
- Concept G5. Gas-cooled Oxide Fuel Fast Reactor System with dry recycling fuel cycle
- Concept G7. High-Energy Neutron Spectrum Modular Helium Reactor (HEN-MHR) for a Sustainable Fuel Cycle
- Concept G16. Enhanced Gas-Cooled Reactor (EGCR).

Two concepts (G16 and G5) are derived from the GFR technology with pin type cores, whereas two concepts (G2 and G7) build on the modular helium-cooled reactor (MHR) technology embodied

by the GT-MHR concept (see Appendix B) with an attempt to take advantage of the benefits of the modular aspects and passive safety features (G2).

The concept set covers a number of technical options that emphasize the range of candidate applications and technologies affordable by GFRs:

Concept	G2	G5	G7	G16
Power (MWe)	200	300-600	300	1400
Conversion	Direct	Indirect	Direct	Indirect Potential for direct
Coolant Temperature	Helium (850°C) Supercritical CO ₂ (650°C)	Helium	Helium (850°C)	Carbon dioxide (525°C)
Hydrogen production		Yes	Yes	
Fuel cycle		Integrated closed fuel cycle with dry processing	Integrated closed actinides fuel cycle	Closed fuel cycle

The HEN-MHR concept (G7), which addresses both reactor and fuel cycle aspects in a consistent nuclear energy system, has been selected as the reference concept. The concept illustrates a vision of an innovative modular, helium-cooled fast nuclear energy system that combines the high economics and safety performances of high-temperature modular thermal reactors with the enhanced sustainability features afforded by fast neutrons. This modular, helium-cooled fast nuclear energy system is described in Section D-3 and its potential to meet Generation IV goals is analyzed in Section D-4. Concepts G2, G5, and G16 illustrate either specific applications of this concept (long-life nuclear battery) or alternative design features that may be considered (e.g., super-critical CO₂ vs. helium, DUPIC as a dry processing method). The salient technical features and the specific merits attached to these concepts are analyzed in Section D-5.

D-3. The Modular, Helium-cooled Fast Nuclear Energy System (Concept G7)

The modular, helium-cooled fast nuclear energy system consists of a modular reactor based on current helium-cooled reactor technology (in particular, the GT-MHR project, concept G10, discussed in Appendix B) with innovative fuel and associated processing technologies that allow for hardened neutron spectra and closed fuel cycles. The use of fast neutrons and closed fuel cycles is intended to meet enhanced sustainability objectives for the fuel cycle, including a minimum production of long-lived radioactive waste and an optimum use of available fissile and fertile nuclear materials. Besides, the option of an integral fuel cycle is intended to minimize transports of nuclear materials and constitute an extrinsic barrier to proliferation risks.

The use of technologies derived from the GT-MHR, especially for the primary system and the balance of plant, aims at making the concept benefit as much as possible from the technology basis developed for this project. This helps focus research and development (R&D) work on the innovations needed in fuel, core design, safety systems, and spent fuel processing to comply with the fast neutron spectrum and its implications, especially on the power density.

Beyond minimizing uncertainties and R&D work, the exploitation of synergies with the GT-MHR is intended to facilitate the changeover from a thermal to a fast mode operating fleet, thus

illustrating the capability of modular gas-cooled reactors of significant evolutions afforded by innovative fuel technologies and associated fuel cycles.

D-3.1 Main Design Features

The main design features of the concept can be summarized as follows:

- Thermal/Electrical Output. 600 MWth/288 Mwe
- Conversion. Direct Brayton cycle with a turbine inlet temperature of 850°C ($\eta \sim 48\%$)
- Reactor Coolant. Helium (500-850°C at 70 bar)
- Fuel. Three different technologies considered for high-fission gas retention up to 1600°C, high heavy atom content, and high burnup capability ($\sim 15\%$ ha)
 - Fuel particles with thin coatings optimized for fast neutron spectrum
 - Composite actinide compound/inert matrix fuels
 - Actinide compound/solid solutions possibly micro-structured for enhanced fission product retention.
- Core Layout.
 - Fuel elements: Prismatic with fuel particles or composite fuels, or pins with actinide compound/solid solution
 - Annular or compact core lay-out (see Figures D-1 and D-2); active H/D $\sim 1.75/3.0$ m for compact core
 - Plutonium content in actinide compound: about 30%
 - Breeding ratio: global value >1.0 with internal breeding ratio above 0.85.
- In-core Power Density. Typically 50 MW/m³
- Cycle Lifetime. 5 to 10 years
- Safety Design Provisions.
 - For Loss of Fluid Accidents (LOFA): natural convection and heat exchange, with heat exchanger mounted at the top of the pressure vessel
 - For Loss of Coolant Accidents (LOCA): long-term passive decay heat removal by conductive and radiative heat transfer across the core and the pressure vessel; pressurized gas injection and natural convection at a back-up pressure of 5 to 15 bar (depending on the gas) assured by the containment of the primary system
 - Three barriers for the containment of fission products, with the containment of the primary system acting as a 3rd barrier.

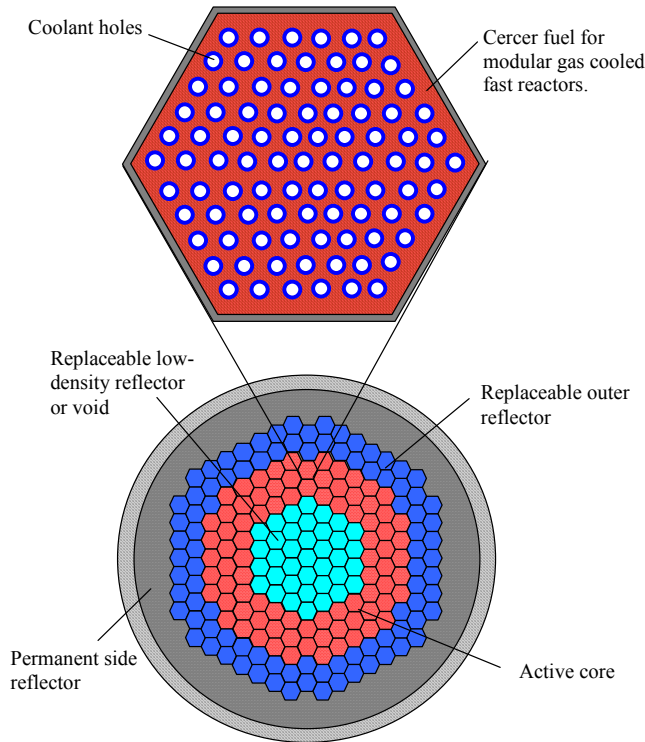

Figure D-1. Schematic diagram of possible core layout with inner reflector for a modular, helium-cooled fast nuclear energy system with ceramics fuel (cercher), or ceramics/metal (cermet) or composite metal (metmet) as back-up solutions.

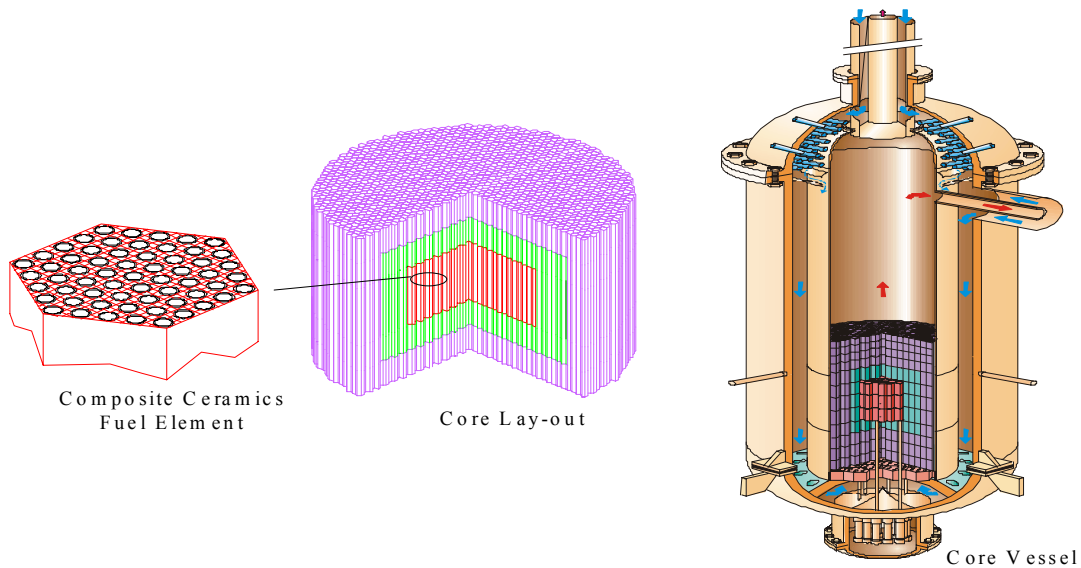

Figure D-2: Schematic diagram of possible ceramics fuel concept, core design features without inner reflector, and general architecture of the reactor vessel for a modular, helium-cooled fast nuclear energy system.

Achieving a completely passive decay heat removal could be achieved by lowering the core power density well below 100 MW/m^3 (as for the GT-MHR and Concept G2, which is purposely designed to comply with a completely passive decay heat removal). Incentives exist, however, to keep the in-core power density of the system at least at 30 MW/m^3 . This would maintain the in-core inventory of plutonium below a few tons while keeping the cycle lifetime shorter than 10 years with a

reasonable discharge burn-up (~10% fissions per initial metal atom (FIMA)). Exploring the range of power densities compatible with a mostly passive safety approach as a function of fuel technology, core design, and decay heat removal strategy—is of specific interest to exploring the limits of the system.

The system offers great flexibility regarding both the variety of high temperature applications (e.g., electricity generation, co-generation, process heat, hydrogen production) and the range of affordable fuel cycles on a stand-alone mode or in symbiosis with LWRs. Beyond the closed uranium-plutonium (U-Pu) fuel cycle, which is selected as reference, the system has enough flexibility to operate with other fuel cycles such as weapons plutonium (WPu), uranium-thorium (U-Th), and plutonium-thorium (Pu-Th).

In summary, the system builds on the current industrial PMR projects to significantly extend the sustainability features of such modular reactors in terms of efficient fertile fuel breeding capability, long-lived radioactive waste minimization, and enhanced resistance to proliferation risks.

D-3.2 Innovative Technologies

As mentioned above, these objectives call for innovative technologies in the field of fuels, materials, safety systems, spent fuel treatment, and re-fabrication processes that mainly consist of:

- Fuels retaining fission products at high temperature, burn-up, and fast fluence
 - Fuel particles with actinides kernels and thin, high-fluence resisting coatings (ZrC, TiN)
 - Composite actinide compound/inert matrix ceramics with high-fission product retention capability
 - Solid solutions, possibly micro-structured for enhanced fission product retention.
- Materials capable of high temperature and fluence as structural or reflector materials for the core and possible constituents of the fuel (coatings, buffers, matrix, cladding)
- Innovative simple processing techniques for actinide spent fuel treatment and re-fabrication for an integrated fuel cycle (fuel particles, composite fuels, other types considered)
- Innovative safety systems for effective and possibly passive decay heat removal based on conduction, radiative, and other means of heat transfer.

D-4. Potential of the Modular Helium-Cooled Fast Nuclear Energy System to Meet Generation IV Goals

The potential of the modular, helium-cooled fast nuclear energy system to meet Generation IV goals are summarized hereafter. A consistent comparison of this system, which includes a reactor with a closed fuel cycle, with the AP-600 operating with an open fuel cycle, is especially difficult for all criteria closely linked to fuel cycle performances and economics (fuel utilization, waste management and proliferation issues, investment and production costs). To be fully consistent, the analyses pertaining to sustainability and economics issues call for a more specific and complete list of criteria.

D-4.1 Sustainability

- SU1-1: Fuel Utilization (++). The combined use of fast neutrons and recycling of actinides (plutonium and minor actinides) enables the system to make use of all available fissile and fertile fuels. This includes not only saving natural resources through breeding (natural

uranium and thorium) but also using the materials generated by the operation of LWRs (plutonium) and fuel cycle plants (depleted uranium from enrichment plants).

Fast neutron systems with sufficient breeding capability and recycling of fissile fuel bred from fertile fuel have the capability to fission about 70% of natural uranium, as opposed to less than 1% in thermal systems such as LWRs (even with recycling of plutonium and reprocessed uranium), or a few percents (< 5%) for high conversion thermal systems ($C \sim 0.8$). The system is best suited for synergistic fuel cycles with LWRs, including burning low-grade plutonium, breeding depleted uranium, and transmutation of minor actinides. Fuel cycles with thorium (potentially in synergy with LWRs) can also be considered.

An additional asset of the system regarding fuel utilization consists in its high thermal efficiency (48% vs. 35% for LWRs), which affords a saving by 1/3 of nuclear fuel consumption. In summary, the system can make an efficient and flexible use of all available nuclear fuels.

- **SU1-2: Fuel Cycle Impact on Environment (+).** The operation of the system with the U-Pu fuel cycle requires no mining activity, owing to the breeding capability of the core and the need for make-up in fertile fuel, such as depleted uranium. This advantage more than offsets potential aspects of the closed and integrated fuel cycle that could be perceived as having a negative impact on the environment, both from a land use and radiological impact point of view (as mining is the activity of the nuclear industry that has the greatest radiological impact) [Pradel 2001]. Furthermore, the system can reuse the large stocks of depleted uranium, which, if not reused, are part of the long-lived radioactive and chemically toxic waste generated by the nuclear industry.
- **SU1-3: Utilization of Other Resources (=).** Helium is the only potentially scarce resource needed by the system. The system rates the same as the GT-MHR in this respect; therefore, the score is assumed to be the same.
- **SU2-1: Waste Minimization (++)**. Fast neutrons provide the system with a capability of intrinsic transmutation of actinides (plutonium, neptunium, americium, curium), which makes it possible to minimize the fraction of these long-lived radio-nuclei in the ultimate waste to 0.1% (Pu) or 1% (Np, Am, Cm) of the amount processed (depending on the performance of the spent fuel treatment processes). This permits reducing the radio-toxicity of the waste by two orders of magnitude, as compared with that of the Advanced Light Water Reactor (ALWR) spent fuel, and reaching within three centuries a nearly equivalent radiotoxicity as that of the natural uranium ore from which the fuel was initially manufactured [Bouchard 2001]. This also permits drastic reduction of the decay-heat generated by the waste in the long term.

As mentioned above, burning depleted uranium also contributes to minimizing radioactive waste. Use of graphite is precluded to achieve fast neutron spectra. Therefore, waste issues regarding the management and disposal of irradiated graphite should not apply to the system. Perceived in Europe as an important issue for the public acceptance of nuclear energy, the long-term radio-toxicity is taken as the leading criterion (before mass, volume, and decay heat criteria) for optimizing the management of nuclear waste [Jacq 2001; Bouchard 2001; Bertel 2001].

- **SU2-2: Environmental Impact (+).** The advantages mentioned above about the excellent fuel utilization (no mining) and intrinsic actinide transmutation capability of the system (minimization of long-lived radio-toxic waste) contribute to alleviate the environmental impact of the system. Additional assets come from the high thermal efficiency that reduces, by about half, the thermal discharge to the environment, in comparison with LWRs. This is a

strong argument to maximize the installed power on a given site with restricted thermal discharge authorizations. The score of the system is consistent with that of the GT-MHR.

- **SU2-3: Stewardship Burden (+/+++).** Minimizing the amount of long-lived radionuclides in the waste (0.1% Pu, 1% minor actinides) drastically reduces the long-term heat load and radio-toxicity of this waste (by a factor of 100, in comparison with spent fuel). Even though, this does not actually reduce the length of societal responsibility, it certainly contributes to alleviate the long-term stewardship burden of the waste generated by the system.
- **SU3-1: Minimize Material Life-cycle Vulnerability (+).** The system is optimized to generate “clean waste” and, therefore, recycles “dirty fuel” (low grade plutonium isotopes and high minor actinides fraction). As such, being highly radioactive and containing a significant fraction of heavy actinides, the fuel recycled in the system is quite unattractive for proliferation activities. Furthermore, spent fuel treatment and re-fabrication are performed in extensively monitored hot cells, which would facilitate the application of safeguard measures.

Moreover, the integration of the fuel cycle in the nuclear site constitutes an extrinsic barrier against diversion, because this minimizes both transports of nuclear materials (restricted to make-up in fertile fuel) and the total amount of nuclear materials needed for the operation of the system over its entire life, as the fissile fuel needed is bred in situ from fertile fuel.

Unattractiveness of “dirty” fuel, relative ease of on-site application of safeguard measures, and minimization of transports of nuclear materials to and from the power station (essentially restricted to waste) constitute a consistent approach to enhance proliferation resistance.

- **SU3-2: Facilitate Material Accounting and Application of International Safeguards (+).** The detectability of highly radioactive “dirty” fuel, the accurate monitoring needed for remote fuel treatment and re-fabrication in hot-cells, and the absence of fissile materials transport from the power station should facilitate the accounting of nuclear materials and the application of international safeguards.
- **SU3-3: Unique Characteristics (+).** Unique features of the system that significantly increases the resistance to proliferation risks result primarily from the specific characteristics of an integrated and closed actinides fuel cycle.

D-4.2 Safety and Reliability Goals

- **SR1-1: Reliability (=).** In comparison with the GT-MHR, the reduced reactivity swing afforded by fast neutron spectrum authorizes longer fuel cycles (from 2 to 10 years). In principle, the system has the potential to reach at least an equivalent capacity factor to that of the GT-MHR. Fuel cycle issues, which are not specifically linked to outage periods, are not anticipated to appreciably affect the reliability of the system.
- **SR1-2: Worker Safety and Routine Exposures (+).** The system requires no mining activity, which is the greatest source of routine exposure of workers. Furthermore, the innovative technology of fuel aims at assuring an equivalent confinement of fission products as standard TRISO fuel particles in normal and abnormal conditions (with negligible release up to 1600°C). The system should, therefore, operate with relatively clean helium systems (with active trapping of activated impurities), which should enhance the worker safety and restrict routine exposures to levels roughly equivalent to those of the GT-MHR. Remote fuel treatment and re-fabrication will be designed with sufficient shielding to remain low in comparison with that attributable to the reactor operation and maintenance.
- **SR1-3: Worker Safety – Accidents (+).** Abnormal plant conditions have much in common with those of the GT-MHR; therefore, the safety of workers is expected to be comparable.

Specific features that could make a difference relate to the fuel cycle operation and to the higher power density in the core, implying the need for active safety systems to remove the decay heat in the short term in case of LOCA. However, as mentioned hereafter, the considered overall safety approach is believed to be comparable with that of the ALWRs, with an advantage attached to the refractory technology of the core, which precludes fuel meltdown.

- **SR2-1: Robust Engineered Safety Features (=/+)**. The safety approach of the system is derived as closely as possible from that of the GT-MHR (taking as much credit as possible from the modular design of the reactor), from the use of helium as coolant (single phase, negligible reactivity feed-back effects, negligible corrosion), and from the refractory technology of the fuel (even though different in nature), which should be designed for a safe operation up to 1600°C without loss of integrity. As mentioned above, the main difference in the safety approach consists in the principle to remove the decay heat in accidental conditions (LOCA, especially), owing to the higher power density in the core (typically one order of magnitude higher). For this safety function, the system makes a combined use of active (for the short term) and passive (for the longer term) decay heat removal systems, thus achieving an effective defense in depth comparable to that implemented in ALWRs.

The system incorporates adequate safety features for a safe management of hypothetical severe plant conditions without significant off-site effects (such as a completely passive decay heat removal by natural circulation, conductive heat transfer through the core, and radiative heat transfer at the vessel surface in case of LOCA).

The facility state transparency is expected to be the same as that of the GT-MHR with an appropriate instrumentation.

- **SR2-2: Uncertainties of System Models (=/+)**. Most of the uncertainties in system models relate to the early stage of definition of the innovative technologies needed for the fuel, the high temperature ceramic materials, and the processes of the fuel cycle. These uncertainties will be reduced by the R&D needed to develop and validate these technologies in relevant conditions before they are implemented in a commercial system.

Other design features are comparable with those of the GT-MHR, including a number of aspects that are anticipated to reduce uncertainties of system models. These include single-phase coolant, negligible coupling between coolant state and reactivity effects, well understood principles of the set of robust safety systems (even though specific data are needed especially to account for convective, conductive, radiative heat transfer), and so forth.

- **SR2-3: Unique Characteristics (=/+)**. Several features contribute to make the system unique in comparison with LMFRs. Its design and, therefore, the safety approach is significantly simpler, namely, (1) helium as a single phase and inert coolant (no reactivity feedback effect, no chemical reactivity with air and fuel), (2) use of a direct conversion system, (3) refractory fuel technology (ceramics) offering excellent resistance to high temperature and neutron damages and precluding core melt-down, and (4) easier inspection and maintenance.

Unique characteristics also include the refractory nature of the ceramics fuel with a desired capability to preserve its integrity and to efficiently confine the fission products at high temperature (1600°C) and high fast neutron fluences (10^{27} n/m², E > 1 MeV).

- **SR3-1: Robustness of Radioactive Materials Release and Transport Mitigation Features (=)**. As mentioned above, the prevention of core damage is based on a consistent set of active (for the short term) and passive (for the long term) safety systems that achieve an effective defense in depth. Additional robustness results from specific mitigation features, such as the excellent resistance to fuel damage up to high temperature and high irradiation

damages, thus avoiding core damages by melt down and massive release of radioactive materials. The core technology is intended to assure a gradual embrittlement of the fuel and ceramic structural materials and a progressive release of fission products in case of hypothetical severe plant conditions.

- **SR3-2: Understanding of Severe Accident Source Terms, Transport, and Dose (=).** The potential source term within the core can be estimated with reasonable confidence. The phenomenology of radioactive releases from damaged fuel directly depends on the fuel technology (particles, composite ceramics) that is still to be defined. The development and the validation of the candidate fuel forms for the system should provide the necessary understanding of the fission gas release modes to confidently predict the effective source term in hypothetical severe plant conditions. This should be complemented by the investigation of specific radio-nuclides transport phenomena involved in severe accident analyses, and the integration of all models and data relevant to the system into a specific version of mechanistic severe accident analysis code (MELCORE, ASTEC).

D-4.3 Economics

The economic features of the system should be comparable with those of the GT-MHR for the reactor component. The impact of the fuel cycle plants on investment and production costs call for a more accurate methodology to obtain a consistent evaluation of the potential of the system than simply comparing the AP-600 operating in an open fuel cycle mode.

- **EC-1: Low Capital Cost (=).** The system is derived from the GT-MHR to benefit as much as possible from the attractive economic features of this modular reactor, especially with regard to capital cost. Modular designs allow for the incremental addition of generating capacity while minimizing financial risks. They should also allow for sharing equipments such as fuel storage facilities, auxiliary power generators, etc. to offset the size effect and keep the capital cost down. The simplicity of the plant design, especially with direct conversion should reduce the number of components and, therefore, the capital cost (especially in comparison with that of the equivalent LMFR).

The fuel cycle plants are based on simple and compact processes to keep the capital cost of this part of the system competitive with that of a centralized fuel cycle plant and assure the same services of spent fuel treatment and re-fabrication. It can also be designed with a modular architecture.

- **EC-2: Low Financial Costs (=).** The arguments above also apply to assure low financial costs. The short construction time of the modular reactor with a maximum number of in-factory manufactured pieces of equipment contributes to keep financial costs down. The same applies to the possibility of operating one module to generate financial income (as early as possible) to alleviate financial charges.
- **EC-3: Low Production Cost (=).** Low production costs should be assured by low financial costs, low operation costs, and low fuel cycle costs. Low operation costs call for the optimization of the reactor and fuel cycle plant modules to efficiently share operating resources (staff, maintenance, equipment). Low fuel cycle costs call for effective control of cost items attached to spent fuel treatment and re-fabrication. The cost of make-up fuel, such as depleted uranium, is negligible. Furthermore, the fuel consumption is reduced by 1/3, owing to the high thermal conversion efficiency of the system.
- **EC-4: Low Development Costs (-).** The system makes extensive use of the GT-MHR technology so as to focus R&D needs on the specific developments needed for the fuel, high temperature materials, the decay heat removal system, and fuel treatment and re-fabrication

techniques. Innovative R&D work in these fields is essential to demonstrate system viability and achieve the aimed performances.

This R&D work is important, owing to the number of technical areas involved, but is not entirely specific to the considered system since high performance fuels and materials (in terms of temperature and irradiation resistance) are of generic interest for future nuclear energy systems. The identification of common R&D pathways with other systems could allow for cost sharing and for reducing specific R&D costs. The generic aspects of several R&D needs should also induce spin-offs in medium industrial projects (especially in the fuel).

- **EC-5: High Profitability (=/+).** As with the GT-MHR, the fast neutron system has the potential for a broad spectrum of high-temperature applications (850°C), including process heat and hydrogen production by advanced electrolysis or thermo-chemical water splitting. It is also well adapted to desalination processes, which use low temperature discharge heat with no impact on the thermal efficiency of electricity generation.

D-5. Review of Specific Features of Candidate Concepts Relevant to the Gas-cooled Fast Reactors Concept Set

D-5.1 Modular, Fast Gas-cooled Reactor–Gas Turbine Cycle (Concept G2)

This concept is a synergistic twin of the GT-MHR (and possibly the Pebble-Bed Modular Reactor project) with an emphasis on characteristics that could make it a secure, robust, and long-life energy source such as a “long life nuclear battery” in the range of 100-300 MWe. In this concept, the fast neutron spectrum is intended to enhance fuel utilization (with a conversion ratio of about 1.0) and assure a reduced reactivity swing, thus allowing very long cycle lifetimes (typically 50 years with an electrical output of 200 MWe).

D-5.1.1 Main Design Features. Main design features of the concept can be summarized as follows:

- **Thermal/Electrical Output.** 450 MWth/200 Mwe
- **Conversion.** Direct Brayton cycle with turbine inlet temperature of 650°C
 - $\eta \sim 37.5\%$ with helium
 - $\eta \sim 45\%$ with supercritical CO₂
- **Fuel Element.** Dispersed fuel in prismatic metal matrix
- **Fuel.** Metal UPuZr in Zr matrix (~5.5% Pu from pressurized water reactor [PWR] spent fuel)
 - UPuN, UPuC as alternatives for fuel
 - Mo, HT-9, Nb, Ti as alternatives for matrix materials
- **Core Layout.** Same annular core as the GT-MHR project (Figure D-1);
 - Inner/outer diameter = 2.6/4.6 m
 - Active height = 8 m
 - Inner reflector replaced by void or (low power) blanket metallic fuel

- Outer reflector made of copper alloys for effective decay heat removal
- In-core Power Density. 7 MW/m³
- Cycle Lifetime. ~50 years

Several advantages are mentioned regarding the use of supercritical CO₂ in place of helium:

- Higher efficiencies of Brayton cycles with lower core exit temperatures (~650°C), thus relaxing material requirements
- Cost advantage owing to the suitability of existing balance of plant technology (within the experience of advanced gas-cooled reactors operated in Great Britain) as opposed to that required for turbine inlet temperatures of 850/900°C
- Less concern with coolant leakage from the primary system.

D-5.1.2 Specific Potential.

Specific potential of concept G2 towards the Generation IV goals can be summarized as follows:

- Sustainability
 - Enhanced proliferation resistance by having a “sealed” core without access to fuel during plant lifetime
- Safety and Reliability
 - Potential for passive cooling at shutdown and in case of LOCA (based on the high thermal inertia and high conductivity of metallic fuel elements combined with the same passive decay heat removal approach used for the GT-MHR)
 - Possible enhancement of negative reactivity feedback effects (Doppler and metallic fuel)
 - Effective fission product retention in dispersed cermet fuel.
- Economics
 - Minimization of uncertainties and R&D work while making extensive use of GT-MHR design and technologies with its advantages of simplified plant design and corresponding reduced operation and maintenance costs.

The options of the fuel cycle in this concept are left open (probably depending on the conditions of use of this “long life nuclear battery”). The fast neutron spectrum in this concept is primarily used to achieve very long core lifetimes with a manageable reactivity swing. Probable burn-up targets of 10 to 15% FIMA for this concept afford a better valorization of the fuel energetic content than LWRs (about 1% even with recycle). However, owing to the low specific power of this concept, this valorization is very slow (10-15% in 50 years), typically one order of magnitude slower than in current LMFBRs. The low specific power also implies a rather high inventory in heavy nuclei (typically 50 tons for 200 MWe), thus leading to the need of high plutonium stocks for the operation of a large fleet of generating facilities based on this concept (typically 14 tons of Pu/GWe).

In conclusion, concept G2 appears as a synergistic twin of the GT-MHR project for a secure, robust and very long life electricity generation in the range of 100-300 MWe. The concept, however,

has limited prospects of generalized deployment in a large generating fleet, owing to the high inventory of nuclear fuel needed.

D-5.1.3 Innovative Technologies.

Innovative technologies supported by concept G2 open prospects for extended performances beyond those of current gas-cooled reactor projects, from which it is derived. These consist mainly of:

- Dispersion fuel in metallic matrix
- Use of supercritical CO₂ as coolant.

D-5.2 Gas-cooled Oxide Fuel Fast Reactor System with Dry Recycling Fuel Cycle (Concept G5)

Concept G5 consists in a typical pin type GFR of 300-600 MWe coupled with an integral fuel cycle using a dry fuel processing and re-fabrication technology such as the DUPIC process jointly developed since the early 1990s by the KAERI and Atomic Energy of Canada, LTD (AECL). The concept aims at supporting the advantages of the integral fuel cycle approach and the specific merits of dry processes like DUPIC to this end. For this reason, the major focus here is on the description of the fuel cycle and associated processes; as such, very few details are given on the reactor design.

In this concept, the fast neutron spectrum is intended to maximize fuel utilization by recycling spent fuel several times.

The main advantages attributed to the DUPIC (or equivalent) fuel cycle approach are:

- It is highly resistant to proliferation, as it does not separate sensitive materials from the spent fuels, and the process takes place entirely in hot cells.
- It affords an attractive reuse of LWR spent fuel, thus offering valuable opportunities of synergistic fuel cycles in most of the present nuclear countries.
- It reduces the waste produced per unit of energy generated (as more energy is produced without increasing the amount of spent fuel).

The DUPIC fuel cycle in Canadian deuterium-uranium reactors has been shown to save natural resources by 30% and to reduce the production of spent fuel by 60%.

D-5.2.1 Main Design Features.

Main design features of the system can be summarized as follows:

- Electric Output. 300-600 Mwe
- Fuel. Oxide fuel pins in compact hexagonal fuel assemblies; innovative cladding (superalloy, ceramic cladding) for extended temperature and burn-up performances
- Reactor Coolant. Helium
- Core Layout. Driver zone with radial blanket assemblies (outer diameter ~ 4.5 m); axial blanket or reflector (height ~ 2.5 m)
- Blanket Seed Materials. Depleted uranium, natural uranium, PWR spent fuel, thorium

- Conversion. Indirect Brayton cycle with secondary helium
- Secondary System. Possible adaptation to a wide range of applications: steam generator, steam reformer, natural gas reformer.

The fuel of the driver zone is manufactured from the spent fuel of the blanket. Addition of enriched uranium is as one possibility to achieve excess reactivity and composition uniformity of the driver fuel, if necessary. This would correspond to breeding performances below unity and, thus, lead to a non-completely sustainable fuel cycle.

Besides electricity generation, hydrogen production is another possible application of concept G5, while coupling the secondary system with a natural gas reforming unit. The various operations of the fuel cycle can be summarized as follows:

- De-cladding of spent fuel
- Succession of thermal cycles of oxidation and reduction (at 400°C and 600°C, respectively)
- Milling to improve the sinter-ability of the powder
- Fabrication of high-quality fuel pellets
- Manufacturing of fuel pins and assemblies.

The whole process operates in hot cells, which are modularized and equipped with instrumentation and controls intended to optimize operation, maintenance, surveillance, safeguards and safety monitoring. During the fuel fabrication process, volatile cesium, krypton, iodine, and xenon are released naturally; transuranic elements and other fission products are retained in the fuel.

D-5.2.2 Specific Potential. Specific potential of concept G5 towards the Generation IV goals can be summarized as follows:

- Sustainability
 - Straightforward adaptation to synergistic fuel cycles with LWRs through the potential of the DUPIC process to directly reuse their spent fuel for plutonium burning or breeding
 - Highly proliferation resistant fuel cycle attributable to on site integration and intrinsic features, such as no separation of sensitive materials from spent fuel and completely remote operation and maintenance in hot cells
 - Potential advantages of the dry fuel cycle process over conventional wet reprocessing for reducing process waste.
- Economics
 - Potential of the dry fuel cycle process, as opposed to the conventional wet reprocessing, for simplifying and modularizing the fuel fabrication process.

In conclusion, concept G5 builds on the experience accumulated by KAERI and AECL in the development of DUPIC fuel treatment and re-fabrication technology for PWR spent fuel to emphasize the assets of dry fuel cycle processes in association with GFRs. These include maximizing the utilization of fuel and reducing the accumulation of long-lived radioactive waste while offering the best prospects for an integral fuel cycle with a high resistance to proliferation risks.

D-5.2.3 Innovative Technologies.

Innovative technologies supported by concept G5 open prospects of extended performances beyond those of the current industrial gas cooled reactor projects. These consist mainly of:

- Dry fuel treatment and re-fabrication processes of DUPIC type as basic technology for an integral and proliferation resistant fuel cycle
- Advanced fuel pin cladding materials, such as super-alloys and ceramics coating
- Advanced structural materials under hard neutron spectrum.

D-5.3 Enhanced Gas-cooled Reactor (EGCR) (Concept G16)

Concept G16 is a fast reactor cooled by carbon dioxide, which uses both the Advanced Gas Cooled reactors (AGR) technology from the United Kingdom and the liquid metal fast breeder core and fuel technology. This concept emphasizes the potential of a design based on proven technology to allow for appropriate economic and safety performances, especially in comparison with LMFBRs.

Fast neutron spectrum in this concept is intended to provide flexibility to manage plutonium in the short term, while providing a long-term breeding capability. It also makes it possible to consider dedicated adaptations of concept G16 for an effective transmutation of minor actinides. No details are given about the possible fuel cycle and the associated fuel cycle plants.

D-5.3.1 Main Design Features.

Main design features of the concept can be summarized as follows:

- Thermal/Electrical Output. 3600 MWth/1400 Mwe
- Conversion. Super-heated steam cycle
 - Turbine inlet conditions of 490°C and 185 bar
 - $\eta \sim 38.9\%$
- Fuel. Hexagonal subassembly (0.167 m across flat) with standard LMFBR pins (mixed oxide with PE16); potential for high burn-up (20% ha)
- Core. 550 hexagonal fuel assemblies, 334 in the inner core/216 in the outer core
 - CO₂ as coolant (42 bar, 250/525°C core inlet/outlet temperature)
 - Active height: 1.5 m
 - 24 control and shutdown rods with screw-drive mechanisms
 - Nine diverse shutdown absorber rods with electromagnets.
- Heat Transfer System. 4 parallel circuits with 3 boilers and 2 gas circulators, each derived from the AGR technology:
 - 300 MWth boiler/steam generator unit with platen style tube bundles made of T91 (9% Cr, 1% Mo)

- Decay heat removal coolers (separate and independent) positioned under each boiler
- Centrifugal circulators driven by electric motors.
- **Reactor Services**. Reactor services located in the individual containment building of each reactor:
 - Separation and segregation of instrumentation and controls both internal and external to the containment buildings, according to the practice in AGRs
 - Possibility of common service facility for circulator maintenance for a twin unit, as for the arrangement on twin unit AGRs
 - In-reactor fuel handling machine located in a central penetration within the reactor roof.

D-5.3.2 Specific Potential.

Specific potential of concept G16 towards the Generation IV goals can be summarized as follows:

- **Sustainability**
 - Flexibility to manage plutonium stocks in the short term while providing a long-term breeding capability, thus allowing for an effective use of nuclear fuel
 - Prospect of dedicated application to the transmutation of minor actinides, thus contributing to the minimization of long-lived radioactive waste.
- **Safety and Reliability**
 - Highly reliable shutdown and decay heat removal systems.
- **Economics**
 - Minimization of uncertainties and R&D work while making extensive use of proven LMFBR and AGR technologies
 - Potential advantages in economics over LMFBRs attached to the use of CO₂ as coolant
 - Simplification with respect to the AGR designs (elimination of flow baffle and graphite in the core, the large number of penetrations in the AGR roof, and the nitrogen injection system for emergency shutdown)
 - Potential for adaptation to higher efficiency and direct cycle.

In conclusion, concept G16 supports the potential assets of combining proven LMFBR and AGR technologies for a 1400 MWe reactor to meet appropriate economic and safety requirements, and to offer additional flexibility to burn plutonium and potentially minor actinides. Concept G16 stimulates the consideration for carbon dioxide as potential coolant for GFRs, as well as for design simplification, from both the LMFBR and the AGR technologies. However, concept G16 does not really support the development of innovative technologies.

D-6. Potential of the Concept Set for Meeting Generation IV Goals

The GFR concept set contributes to demonstrate the potential of high-temperature gas-cooled reactors to make significant progress towards sustainability goals beyond the performances of current industrial projects, such as the MPBR and the GT-MHR, which have been identified as leading concepts for two other concept-sets. With an approach extensively based on the reuse of proven or near-term technology (GT-MHR for concept G2 and G7, LMFBR and AGR for concepts G2 and G16), the concept set emphasizes the capability of significant evolutions of GFRs afforded by innovative fuel technologies and associated fuel cycles, such as a changeover from a thermal to a fast neutron spectrum. Furthermore, it illustrates the capability of fast neutrons systems with a closed and integrated fuel cycle to make an efficient and flexible use of available fertile and fissile materials, minimize the production of long-lived radioactive waste, and offer appropriate resistance to proliferation risks. Even though its constituent concepts appear diverse in nature, the GFR concept set supports the vision of a modular, helium-cooled fast nuclear energy system capable of enhanced sustainability features beyond the capability of intermediate-term industrial projects. In this sense, all GFR concept sets could be considered as a consistent range of systems with two industrial projects being relevant to Generation IV criteria, and two other concept-sets demonstrating a significant potential of further progress towards the Generation IV goals for the longer term. Besides, all concept-sets of gas-cooled systems support the vision that this type of high-temperature nuclear heat source may serve a wide range of applications besides electricity generation (e.g., co-generation, process heat, hydrogen production) and may be operated with a variety of fuel cycles, both on a stand-alone or a synergistic mode with LWRs.

D-6.1 Evaluation against Criteria / Metrics

Generic advantages that are evidenced by the analysis of this concept set are as follows:

- **Sustainability**. Assets of fast neutron spectrum:
 - For effective and flexible utilization of available fissile and fertile fuels, both from natural resources and from operating PWRs
 - For minimizing the amount of long-lived radioactive nuclei in the ultimate waste
 - For synergistic fuel cycles with operating LWRs, especially for burning low-grade plutonium and possibly transmuting minor actinides (as dedicated application)
 - For accessibility to a wide range of fuel cycles (U-Pu, U-Th, Pu-Th, WPu).
- **Safety**. Comparison with current LMFR technology:
 - Negligible coolant void reactivity effect
 - Possibility of Doppler effect enhancement
 - Need for a more active management of shutdown cooling and decay heat removal in case of LOCA, owing to a lesser thermal inertia and less effective heat transport capability (except for G2, which is extensively based on a passive safety approach as it operates at very low specific power).
- **Economics**. Comparison with current LMFR technology:
 - Greater design simplicity, especially in case of direct conversion

- Potential for conversion efficiency well above 40%.
- Other Applications than Electricity Generation. Potential for high-temperature process heat generation and hydrogen production by thermochemical water splitting above 850 C.

D-6.2 Summary of Concept Set Potential

The strength of the GFR concept set clearly relates to its potential for high sustainability and performances in terms of energetic valorization of fuel and long-lived waste minimization, greater by one order of magnitude than those accessible to thermal neutron systems. The strength could also be the capability of extremely long cycle lifetimes for specific applications, such as a secure, robust, and “long-life nuclear battery.” As counterpart, the main question about the concept-set relates to the prospective aspects of some of the needed technologies that require a substantial R&D effort with corresponding uncertainties.

D-7. Technical Maturity of Concept Set and Technology Potential Versus R&D Risk

The specific application to a secure, robust, and “long-life nuclear battery” appears to be a rather straightforward adaptation of the GT-MHR project with two specific technologies:

- Dispersion fuel in metallic matrix (Zr)
- Use of supercritical CO₂ as coolant.

These technologies both have a strong technical background and offer best prospects of successful development with limited uncertainties.

Gas-cooled fast nuclear energy systems with a closed integrated fuel cycle can be envisioned with incremental R&D from available or near-term technologies implemented in past and current reactor projects such as GT-MHR, LMFBRs and AGRs. GCFR fuel and DUPIC dry processes for the fuel cycle are recognized as available technologies to possibly meet these goals. However, advanced solutions with significant potential for progress, in terms of economic competitiveness and more passive safety approaches, can reasonably be expected from more advanced technologies:

- Fuels resisting at high temperature, high burn-up, and fast fluence with high fission product confinement capability:
 - Fuel particles with actinides kernels and thin high fluence resisting coatings (ZrC, TiN)
 - Composite actinide compound/inert matrix ceramics with high fission product retention
 - Solid solutions, possibly micro-structured for enhanced fission product retention
- Materials resisting at high temperature and high fluence as structural or reflector materials for the core and possible constituents of the fuel (coatings, buffers, matrix, cladding)
- Innovative, simple, and compact processing techniques for actinide spent fuel treatment and re-fabrication for an integrated fuel cycle (fuel particles, composite fuels, other types considered)
- Innovative safety systems for effective and possibly more passive decay heat removal based on conduction, radiative and other means of heat transfer.

Research and development needed in these areas should seek for breakthroughs and are subject to some uncertainties. Fundamental research and modeling are essential to achieve effective breakthroughs, especially in the field of materials science. Several technologies key to R&D for future generation nuclear energy systems appear to be of generic interest:

- Nuclear fuels with high performances in terms of temperature, burn-up, fast fluence
- High performance materials in terms of temperature and fast fluence (ceramics, metallic, composite)
- Basic partitioning techniques (hydro-, pyro-, physical) and re-constitutive techniques for a simple and compact integrated fuel cycle
- Passive heat transfer principles to enhance the passive decay heat removal capability in case of LOCA and to make it comply with relevant power densities (10's MWth/m³).

Therefore, the identification of common R&D pathways with other systems—especially with intermediate-term industrial projects—could allow for sharing R&D costs and reducing specific development costs. Furthermore, the generic aspects of several R&D needs of the system should also induce spin-offs in medium industrial projects (especially in the fuel).

D-8. References

Bertel, E., “Nuclear Energy in a Sustainable Development Perspective,” GLOBAL 2001 International Conference on *Back-end of the fuel cycle*, Paris, France, September 9-13, 2001.

Bouchard, J., “Research and Development on nuclear energy for the future,” GLOBAL 2001 International Conference on *Back-end of the fuel cycle*, Paris, France, September 9-13, 2001.

Jacq, F., “The Radioactive Waste Management and Disposal Program in France,” GLOBAL 2001 International Conference on *Back-end of the fuel cycle*, Paris, France, September 9-13, 2001.

Pradel, Ph., “Spent fuel Reprocessing at La Hague Plant: Towards a Zero Impact,” GLOBAL 2001 International Conference on *Back-end of the fuel cycle*, Paris, France, September 9-13, 2001.

Table D-1: Screening for potential score sheet of the Modular helium cooled fast nuclear energy system

Scoring by Goal

Much worse than reference	Worse than reference	Similar to reference	Better than reference	Much better than reference
--	-	=	+	++

Goal Sustainability 1				
SU-1-1 Fuel Utilization				++
SU1-2 Fuel cycle impact on environment				+
SU1-3 Utilization of other resources				
Goal Sustainability 2				
SU2-1 Waste minimization				++
SU2-2 Environmental impact				
SU2-3 Stewardship burden				++
Goal Sustainability 3				
SU3-1 Material life-cycle vulnerability				+
SU3-2 Application of extrinsic barriers				+
SU3-3 Unique characteristics				+
Goal Safety and Reliability 1				
SR1-1 Public/worker - routine exposures				+
SR1-2 Worker safety - accidents				+
SR1-3 Reliability				
Goal Safety and Reliability 2				
SR2-1 Facility state transparency				
SR2-2 System model uncertainty				+
SR2-3 Unique characteristics				+
Goal Safety and Reliability 3				
SR3-1 Highly robust mitigation features				+
SR3-2 Damage/transport/dose understood				+
SR3-3 No additional individual risk				
SR3-4 Comparable societal risk				
Goal Economics 1 and Goal Economics 2				
EC-1 Low capital costs				+
EC-2 Low financial costs				+
EC-3 Low production costs				+
EC-4 Low development costs				145
EC-5 High profitability				+

- Effective and flexible utilization of available fissile and fertile nuclear fuels from natural resources and LWRs.
- Potential for breeding and for synergistic fuel cycles with LWRs: burning low grade Pu, transmutation of minor actinides.
- No mining of Uranium: low resource utilization and low exposure to workers.
- Low thermal discharge (48 % conversion efficiency).
- Minimization of long-lived radioactive nuclides in the ultimate waste (<0.1% Pu and <1% minor actinides). Minimization of long-term radiotoxicity and decay heat.
- No graphite waste issue.
- Unattractive «dirty» fuel for proliferating activities (low grade Pu isotopics, high contents in Minor Actinides).
- Integrated fuel cycle as extrinsic barrier against diversion.
- Supply of nuclear materials limited to make-up of fertile fuel over the plant life.
- Low worker exposure: no mining, low activation of primary system, remote fuel processing and fabrication.
- Capacity factor comparable with that of the ALWR.
- Need for an active management of shutdown cooling and decay heat removal in case of LOCA (owing to a higher power density than modular thermal HTRs).
- Facility state transparency comparable with that of ALWRs with robust engineered (for the short term) and passive (for the long term) safety features.
- Single-phase coolant with negligible reactivity feedback.
- Excellent resistance to fuel damage – Core meltdown precluded by ceramics fuel technology – High fission product confinement performances up to 1600°C.
- Greater design and operating simplicity than LMFBRs.
- Potential for a conversion efficiency well above 40%.
- Economic features of the reactor comparable with those of the ALWR – Impact and features of a closed and integrated fuel cycle to be assessed on a consistent basis.
- R&D of generic interest needed for breakthroughs in fuels, materials, safety systems and fuel cycle processes.
- Flexibility for a wide range of applications (electricity, process heat, hydrogen, desalination...) and fuel cycles.

APPENDIX E

**Gas-Cooled Reactor Systems
Fuel Cycle Flexibility**

CONTENTS

ACRONYMS.....	149
E-1 GENERAL CONSIDERATIONS.....	153
E-1.1 Basic Advantages of HTRs.....	153
E-1.2 A Classification of Fuel Cycles in HTRs.....	153
E-2 URANIUM-BASED CYCLES.....	154
E-2.1 The HEU Cycle.....	154
E-2.2 The LEU Cycle.....	155
E-2.3 The MEU Cycle.....	155
E-2.4 Combination of Various Cycles (“Symbiotic” Cycles).....	155
E-3 PLUTONIUM CYCLES.....	156
E-3.1 General Studies.....	156
E-3.2 “All Plutonium” Cycle.....	156
E-4 Conclusions.....	157

ACRONYMS

GA	General Atomics
HEU	high-enriched uranium
HTR	High-Temperature, Gas-Cooled Reactor
HTTR	High Temperature Engineering Test Reactor
LEU	low-enriched uranium
LWR	light water reactor
MEU	medium-enriched uranium
MOX	mixed oxide (fuel)
OECD	Organization for Economic Cooperation and Development
PWR	pressurized water reactor
R&D	research and development
TRU	transuranic (waste)

Appendix E

Gas-Cooled Reactor Systems Fuel Cycle Flexibility

GCR VARIOUS FUEL CYCLE FLEXIBILITY

E-1 General Considerations

E-1.1 Basic Advantages of HTRs

High temperature, gas-cooled reactors (HTRs) have several fundamental characteristics that distinguish them from other types of reactors and provide significant operational advantages. In particular, the fuel is in the form of small ceramic-coated particles, capable of Very-High-Temperature operation, the moderator is solid graphite, and the coolant is neutronically inert helium.

One of the benefits of such a fuel arrangement is that HTRs are able to accommodate a wide variety of fissile and fertile material mixtures without any significant modification of the core design. This flexibility is due to an uncoupling between the parameters of cooling geometry and the parameters that characterize neutronic optimisation (i.e., moderation ratio or heavy nuclide concentration and distribution). It is possible to modify the packing fraction of coated particles in the fuel within the graphite matrix without changing the dimensions of the fuel elements (number and diameter of cooling holes for prismatic blocks cores or pebble diameter for pebble bed cores). Other physical reasons favor the much better adaptability of HTRs with regard to the fuel cycle in comparison with reactors using moderators in the liquid form, such as light water reactors (LWRs). An illustration of that is the void coefficient that limits the plutonium content of pressurized water reactor (PWR) mixed oxide (MOX) fuels², but is not a constraint for HTRs. An HTR core has a better neutron economy than an LWR because there is much less parasitic capture in the moderator (capture cross section of graphite is 100 times less than the one of water) and in internal structures.

Finally, HTR fuels are able to reach very high burn-ups, which are far beyond the possibilities offered by other thermal reactors (except the particular case of molten salt reactors). This capability allows for essentially complete plutonium fission in a single burnup and minimizes the proliferation risk in the use of this fuel form.

E-1.2 A Classification of Fuel Cycles in HTRs

Numerous studies have been carried out in the past to assess and compare merits and drawbacks of all solutions that may be considered in HTRs, and which depend on:

- the type of fissile material (U-233, U-235, Plutonium) or fertile material (Th-232, U-238) with various enrichments
- utilisation conditions in the reactor: moderation ratio, frequency of reloads, fraction of the core replaced at each cycle, distribution of fertile and fissile materials among various categories of particles

² If a total loss of water occurs in a PWR, the neutron spectrum becomes very fast due to the reduced moderation. In these conditions, neutron multiplication by plutonium isotopes increases significantly because of better neutron reproduction of plutonium isotopes in the fast range.

- fissile material recycling strategy

A large number of results is available today, with the four main categories of fuel cycles summarised as follows:

- 1) High enriched uranium (HEU) cycle based on thorium utilization as a fertile material and HEU (typically 93 %) as a fissile material
- 2) Low enriched uranium (LEU) cycle where only enriched uranium is used (from 5 % to 12 %)
- 3) Medium enriched uranium (MEU) cycle, which is an intermediate cycle between HEU and LEU, using a combination of thorium and a 20 % enriched uranium
- 4) Plutonium cycle based on the utilization of plutonium only as a fissile material, with (or without) fertile materials.

E-2 Uranium-Based Cycles

E-2.1 HEU Cycle

Thorium, being the fertile material utilized in this cycle, generates U-233, which is by far the best fissile isotope for thermal spectrum reactors³. Furthermore, there are more known thorium resources than uranium resources⁴, and its utilization as a fertile isotope in reactors has been extensively studied, particularly for HTRs.

For these reasons, the HEU cycle was considered as the reference cycle at the very beginning of HTR development in both the USA and Germany. As a result, four HTR prototype power reactors (Arbeitsgemeinschaft Versuchsreaktor and Thorium Hochtemperatur Reacktor in Germany, Peach Bottom and Fort Saint Vrain in the USA) were loaded with fuel containing thorium in various forms such as carbides, oxides, and single thorium particles or mixtures with uranium.

The main advantage of this cycle is to significantly reduce uranium consumptions (typically 30 to 40 % for “standard” cycles). Another advantage, which was not underlined in the past but which may become an important argument, is the significant reduction of radiotoxicity of the waste if U-233 is recycled in reactors. This would occur in reactors operated with Th/U-233 cycles.

On the other hand, the competitiveness of an HEU cycle is questionable today, all the more so since there is a large uncertainty on thorium costs due to the limited market for this material. The main technical hurdle for the development of the HEU cycle arises when U-233 recycling is envisaged. This is

³ Typically, in a thermal spectrum as the one of HTRs (or LWRs), reproduction factor of neutron η reaches 2.29 for U-233, while it is only 2.05 for U-235 and only 1.80 for Pu-239. Incidentally this makes it theoretically possible to achieve breeding conditions in a thermal spectrum reactor with a fuel using thorium and U-233. This was experimentally demonstrated in the Shippingport reactor in the USA in the late 1970's, but with the use of technological tricks, which would be difficult to extrapolate to an industrial NPP.

⁴ Thorium is reputedly more abundant than uranium, although its limited use so far has not led to prospect it very extensively. The world's reasonably assured reserves (RAR) are known to be at least as important as those of uranium and quite probably higher (a ratio of 3 is often reported in the literature). Very large deposits have been found in several countries such as India, Canada, Turkey and Brazil.

not strictly necessary, but strongly increases the benefit of thorium use. The difficulty arises from the significant energetic γ emission of some daughter products of U-232 (7-year period), which comes with U-233. This harmful emission essentially requires a remote fabrication process of U-233 fuels. Technically, this operation is certainly feasible with modern technologies, but significant research and development (R&D) effort would be necessary to industrialize it and to ensure its profitability. On the other hand, the radiation levels from U-232 would act as a major deterrent for diversion of the U-233 for weapons purposes. Proliferation concerns are of course a major concern with any fuel cycle.

E-2.2 LEU Cycle

The LEU cycle uses uranium with a minimum enrichment of 5 to 6 %, which is more than the highest enrichments usually utilized in other current thermal reactors, such as LWRs. This is due to a rather diluted and homogeneous uranium distribution in HTR fuels, which favours U-238 resonance captures⁵. This greater neutron absorption must be compensated for by a higher enrichment. On the other hand, this apparent enrichment penalty goes with a higher conversion ratio (typically 0.7 to 0.8 or even more if needed), which leads globally to less uranium consumption because of a higher “in situ” formation of fissile isotopes (plutonium). It also provides for a more uniform reactivity behaviour of the core life.

The LEU cycle was studied during the 1960’s and 1970’s in the USA and Germany, as well as in England and in France. Within France, LEU was chosen as a reference cycle for HTR designs because a minimum of R&D was needed. Some LEU fuels were loaded in the Organization for Economic Cooperation and Development (OECD) experimental DRAGON reactor. Furthermore, Germany decided in the 1980’s to select this fuel for their future projects. Japan has also selected this fuel for their experimental High-Temperature Engineering Test Reactor (HTTR), which is in operation today.

E-2.3 MEU Cycle

Studies on this intermediate cycle were initiated in the late 1970’s in the USA within the framework of the non-proliferation policy of President Carter. At that time, it was desired to search for fuel cycle technologies capable of minimizing as much as possible the risk of using fissile materials for manufacturing nuclear weapons (proliferation resistance fuel cycle). In this respect, HEU cycles were considered very proliferant and were not allowed. This led to the idea of so called “denatured” cycles, with an U-235 enrichment limited to an allowable value of 20% (or 12% in U-233), including a certain amount of thorium. Studies devoted to this cycle were actually limited and mainly carried out by General Atomics (GA) in the USA. This cycle is still considered by GA as the reference cycle for their present modular reactor projects.

E-2.4 Combination of Various Cycles (“Symbiotic” Cycles)

Within the framework of a global strategy for management of natural resources and wastes, a combination of various cycles may be considered in a given national fleet of reactors. For example, HTRs operating with HEU cycles may be mixed with dedicated reactors burning only U-233 (Th/U-233 cycle) produced by an HTR’s HEU. An association of two different reactor types may also be envisaged. The first type may be LWRs producing plutonium, and the second type may be a set of HTRs burning only plutonium. A quick survey of these plutonium cycles for HTRs is given below. HTRs are also easily

⁵ The self-shielding effect of resonances is less important. When an isotope having absorption resonances is concentrated, the neutron flux is depressed in space and energy for neutrons which are at the energy of resonance. This phenomenon reduces effective absorption of the isotope in a great deal.

adaptable to the use of the transuranic (TRU) waste, reprocessed from power reactor operation, since they can operate with a complete core of non-fertile plutonium fuel. Thus they can significantly reduce the high-level waste inventory in the nuclear fuel cycle and essentially eliminate the proliferation risk from the plutonium that has been produced while generating useful energy at high efficiency from this material.

E-3 Plutonium Cycles

E-3.1 General Studies

The idea to use plutonium as the only fissile material, but still with thorium as a fertile material, was considered very early in the 1960's within the framework of the DRAGON project. GA took up the studies in 1968 in a program with Edison Electric Institute. This program was carried out up to the manufacturing of a test fuel element and its irradiation in the Peach Bottom HTR.

From a physics standpoint, the interest of plutonium use in HTRs comes from flexible features already discussed in Section E-1. It is known that plutonium isotopes have very large capture resonances near the thermal range of the neutron spectrum⁶. This is the reason why plutonium reactivity and evolution as a function of time heavily depends upon its initial concentration and distribution in the fuel (because of self-shielding effect mentioned above). In that respect, an HTR provides a large margin to the designer for optimising fuel cycle characteristics.

Initial studies considered plutonium as a simple make-up mixed with other fissile isotopes (U-235 or U-233). However, these solutions, while feasible, led to rather complex optimisations, particularly because of heterogeneities in power distribution for HTRs with prismatic blocks. Therefore, the more attractive solution of using only plutonium as a fissile material was considered. Among the benefits of this configuration are:

- higher plutonium burnups compared to LWRs
- possibility of a cycle based on a refuelling of the entire core at each reload operation.

This last benefit was particularly interesting since it allows a power peak reduction and, therefore, an increase of core outlet temperatures while suppressing helium flow rate control devices of each channel in large cores with prismatic blocks. Another interesting feature is the slower variation of reactivity versus time⁷, which allows reduced control absorbers, leading to a better neutron economy.

E-3.2 "All Plutonium" Cycle

To maximize plutonium consumption, more recent studies have been performed on plutonium HTR cores with no fertile material at all. This solution has been particularly considered in the framework of weapon-grade plutonium consumption. For the reasons already discussed above, only HTRs offer such a possibility (apart from fast neutron reactors for which it seems theoretically feasible to design a core containing only plutonium).

As far as net plutonium consumption is concerned, performances claimed for this type of fuel cycle are remarkable. For example, if we refer to joint studies between GA and MINATOM on what they call

⁶ Particularly the "giant" resonance of Pu-240 at 1eV (100,000 barns at the peak)

⁷ The harder spectrum of HTRs leads at a more rapid formation of Pu-241 from Pu-240.

the “Plutonium Consumption – Modular Helium Reactor”, plutonium consumption reaches 94 kg/TW(e)hr⁸. As a guide, a European Pressurized Reactor loaded with 100% MOX fuel could theoretically consume 65 kg/TW(e)hr. One can also compare with a Fast Neutron Reactor operating on “under-breeding” mode, which could achieve a theoretical consumption of 80 kg/TW(e)hr provided that advanced fuel containing 45% of plutonium are developed (see French “CAPRA” program).

The development and qualification of an “all plutonium” HTR fuel, capable of reaching very high burnups (500 GWd/t) would require a significant R&D effort. However, some experimental fuels were tested at such burnups in the past under the DRAGON project; and TRISO coated fuel particles containing only weapons-grade plutonium, and thorium-plutonium mixtures were successfully tested in the Peach Bottom HTR to 95% Pu-239 destruction (747,000 MWD/MT of burnup).

The U.S. Department of Energy selected the MOX fuel rather than this option for the near-term isolation of military plutonium disposition because of its potential costs and development delays. Further studies are needed to demonstrate the overall reactivity control and stability for this type of core.

E-4 Conclusions

This overview explains why HTRs are able to accommodate a wide range of fuel cycle types without significant changes in their design. This flexibility is unique and not possible in other thermal reactor types. Moreover, the fact that HTR fuels can reach very high burnups increases their capacity in terms of uranium and thorium utilization even for a once through fuel cycle. Recycling of fissile materials significantly improves this utilization, especially as one can reach high conversion ratios with HTRs.

It must be noted, however, that even though a rather large experience has already been gained in HTR fuels, significant R&D effort would be still necessary to perfect a high performance fuel on an industrial scale. In the same way, if reprocessing were to be considered, it would be necessary to launch a fairly large R&D program to define and operate an efficient industrial process.

From the analysis presented here, the following conclusions can be drawn:

- In spite of its potential advantages, the HEU cycle appears to be dismissed because of proliferation concerns. However, it should be worthwhile to carry out further studies to better assess its potential benefits with regard to other questions, such as minor actinide generation, which took much more importance in recent years.
- The LEU cycle benefits from the largest experience but needs a uranium enrichment beyond 5%, which is the upper limit for most of fuel cycle facilities in many countries. It would be necessary to modify these facilities or to build new plants (particularly for enrichment), knowing that in any case new fuel fabrication plants are needed to manufacture HTR fuels.
- The MEU cycle cumulates some drawbacks of the HEU cycle (necessity of new facilities to manipulate and process thorium) and LEU (enrichment) without any significant advantage other than to comply with the upper enrichment limit of 20%.

⁸ It is easy to verify this figure by using a 47 % efficiency of the plant, and elementary fission energy release of 200 MeV

- Thorium use is not specific to HTRs, even though they are better adapted than other reactors to take advantages of thorium properties.
- For plutonium consumption, HTRs are without a doubt one of the best type of reactors. Only fast neutron reactors may compete in this domain, but at the cost of as much or more development as HTRs. Taking into account the acquired technological background on HTR fuels, it seems that there is no technological hurdle to achieve expected performances of plutonium consumption. However, 20 years ago the context was not the same and, in particular, questions such as plutonium consumption or long-term waste management were not so acute. It should be worthwhile to reconsider this option in light of these new challenges.

APPENDIX F

Table of Requests for Information, Responses, and Technical Working Group Concepts

Appendix F

Table of Request for Information Responses and Technical Working Group Concepts

#	P.O.C.	Org. Name	Org. Type	Country	Reactor Type	Fuel	Coolant	Moderator	Comment	Concept Group
G1	van Dam	Delft University of Technology	University	Netherlands	Gas Cooled Fluidized Bed	Enriched Uranium	Helium	Graphite	Fluidized bed of TRISCO-coated fuel particles	Other
G2	Hejzlar	Massachusetts Institute of Tech	University	USA	Gas Cooled Metal Matrix	U CERMET or METMET	CO2	None-fast reactor	Emphasis on fast vs. thermal neutron spectrum	FBR
G3	Sekimoto	Tokyo Institute of Technology	University	Japan	Gas Cooled Block-Type	Thorium	Not Specified	Graphite	Emphasis on benefits of CANDLE burnup	Other
G4	van Heek	NRG	Industry	Netherlands	Gas Cooled Pebble Bed	U/Th coated particles	Helium	Not Specified	40 MWth unit with combined heat and power capability	PBR
G5	Choi	KAERI	National Lab	Korea	Gas Cooled Fast Reactor	Recycled oxide fuel	Helium	Not Specified	Combines gas cooled fast reactor with dry recycle of fuel	FBR
G6	Pahladsingh	Pahladsingh Holding BV	Industry	Netherlands	Simplified Gas Cooled Reactor	Pebble Bed	Helium	Not Specified	Transportable modular gas cooled reactor in 3 modules.	PBR
G7	Rouault	CEA	National Lab	France	HEN-MHR	Research Required	Helium	None-fast reactor	Fast neutron, gas cooled, gas turbine, onsite recycle	FBR
G8	Baxter	General Atomics, Framatome, etc.	Industry	USA	Modular Helium Reactor	LEU coated particles	Helium	Graphite	Simplified version of Modular-Helium Reactor with gas turbine	PMR
G9	Bresenbruch	General Atomics	Industry	USA	Very High Temp Gas Cooled	Ceramic or carbide	Helium	Graphite or BeO	Very high temp for higher efficiency and H2 production	VHTR
G10	Shenoy	General Atomics	Industry	USA	Modular Helium Gas Turbine	Coated particles	Helium	Graphite blocks	"Standard" version of modular gas reactor with gas turbine	PMR
G11	Shenoy	General Atomics	Industry	USA	Modular HTGR Steam Cycle	Coated particles	Helium	Graphite blocks	"Standard" version of modular gas reactor with steam turbine	PMR
G12	Shenoy	General Atomics	Industry	USA	Modular HTGR Process Heat	Coated particles	Helium	Graphite blocks	"Standard" version of modular gas reactor for process heat	PMR
G13	Baxter	General Atomics	Industry	USA	Modular Helium Reactor	Coated particles	Helium	Graphite blocks	Gas reactor with fuel adapted to burn LWR TRU waste	PMR
G14	Hassberger	LLNL	National Lab	USA	Moving Zone Fast Reactor	Th or U w/ 30-yr life	Helium	None-fast reactor	Fertile/fissile burning and breeding moving neutron wave front	Other

#	P.O.C.	Org. Name	Org. Type	Country	Reactor Type	Fuel	Coolant	Moderator	Comment	Concept Group
G15	Ougouag	INEEL	National Lab	USA	Re-configurable Pebble Bed	Pebble Bed	Helium	Graphite	Optimize core with deterministic reconfiguration	PBR
G16	Lennox	NNC Limited	Industry	England	Enhanced Gas Cooled Reactor	PE16 clad MOX rods	CO2	None-fast reactor	UK AGR & LMFBR technology	FBR
G17	Kugeler	Inst. for Safety Research	National Lab	Germany	Annular Pebble Bed Reactor	Pebble Bed	Helium	Graphite	Pre-stressed cast-iron Pressure Vessel	PBR
G18	Ogawa	Japan Atomic Energy Research Institute	National Lab	Japan	High Temperature Prismatic Reactor	LEU	Helium	Graphite	Very-High-Temperature to maximize hydrogen production	VHTR
C02	Kadak	Massachusetts Institute of Tech	University	USA	Pebble Bed Rx	LEU	Helium	Graphite	Similar to PBMR with IHX or direct GT.	PBR
C03	Finck	Argonne National Lab.	National Lab	USA	Prismatic Fast Gas Cooled	U/PU or U/Th	Helium	Fast Rx	PMR with either direct or indirect heat exchanger	FBR
C05	Kadak	Massachusetts Institute of Tech	University	USA	Cs Based Rad. Enhanced MHD	Coated particles	Helium	Graphite	MHD electrical generation	Other

APPENDIX G

Modular Helium Reactor for Non-Electric Applications of Nuclear Energy

**MODULAR HELIUM REACTOR
FOR
NON-ELECTRIC APPLICATIONS
OF NUCLEAR ENERGY**

by

ARKAL S. SHENOY

NOVEMBER 1995



DISCLAIMER

This report was prepared as an account of work sponsored by an agency of the United States Government. Neither the United States Government nor any agency thereof, nor any of their employees, makes any warranty, express or implied, or assumes any legal liability or responsibility for the accuracy, completeness, or usefulness of any information, apparatus, product, or process disclosed, or represents that its use would not infringe privately owned rights. Reference herein to any specific commercial product, process, or service by trade name, trademark, manufacturer, or otherwise, does not necessarily constitute or imply its endorsement, recommendation, or favoring by the United States Government or any agency thereof. The views and opinions of authors expressed herein do not necessarily state or reflect those of the United States Government or any agency thereof.

**MODULAR HELIUM REACTOR
FOR
NON-ELECTRIC APPLICATIONS
OF NUCLEAR ENERGY**

ARKAL S. SHENOY

This is a preprint of a paper for IAEA TECDOC on "Non-Electric Applications of Nuclear Energy", This paper was presented at the IAEA Advisory Group Meeting held in Jakarta, Indonesia, on 21-23 November, 1995

**GA Project 2736
NOVEMBER 1995**



MODULAR HELIUM REACTOR FOR NON-ELECTRIC APPUCATIONS

Arkal Shenoy, Ph.D.
Manager, Systems Engineering
Power Reactor Group
General Atomics, San Diego

ABSTRACT

The high temperature gas-cooled Modular Helium Reactor (MHR) is an advanced, high efficiency reactor system which can play a vital role in meeting the future energy needs of the world by contributing not only to the generation of electric power, but also the non-electric energy traditionally served by fossil fuels. This paper summarizes work done over 20 years, by several people at General Atomics, how the Modular Helium Reactor can be integrated to provide different non-electric applications including Process Steam/Cogeneration for industrial applications, Process Heat for transportation fuel development and Hydrogen Production for various energy applications.

The MHR integrates favorably into present petrochemical and primary metal process industries, heavy oil recovery, and future shale oil recovery and synfuel processes. The technical fit of the Process Steam/Cogeneration Modular Helium Reactor (PS/C-MHR) into these processes is excellent, since it can supply the required quantity and high quality of steam without fossil superheating.

High temperature process heat is a second example of how the MHR can be extended to use its full temperature capability. In terms of market application, transportation fuels represent the largest potential application for a Process Heat Modular Helium Reactor (PH-MHR) system. Potential fuels could include methane or synthetic gasoline using various feedstocks. One interesting application described in this paper is the production of methanol from coal.

Hydrogen can play a major role in reducing global CO₂ emissions in the 21st century. Produced using nuclear energy, hydrogen can replace many existing fossil fuels such as oil and coal, in providing a CO₂ free energy supply for many stationary and transportation uses. The Modular Helium Reactor (MHR) system can deliver the required electric energy and is unique in its capacity to supply high temperature process heat for thermochemical production of hydrogen. Three distinct hydrogen production processes and their interface with the MHR heat source in those processes are presented. Assessment of these and other nuclear approaches to the production of hydrogen can be undertaken to assure the availability of hydrogen production processes early in the 21st century.

1 INTRODUCTION

Today the world's primary energy consumption by its 5.4 billion inhabitants is about 320 quads per year (1 quad = 10^{15} BTU). Approximately two thirds of this is utilized in non-electric applications. The Modular Helium Reactor (MHR) is a second generation passively safe reactor system which can play a vital role in meeting the future energy needs of the world by contributing not only to the generation of electric power, but also to the industrial non-electric energy sector traditionally served by fossil fuels. Most energy-intensive industrial processes require considerable process steam and electric power.

In the industrial nations, transportable fuels in the form of natural gas and petroleum derivatives constitute a large energy source. Nations with large coal deposits have the option of coal conversion to meet their transportable fuel demands. But these processes themselves consume large amounts of energy and produce undesirable combustion by-products. The modular helium reactor system has the potential of providing the required energy to produce transportable fuel.

Global carbon dioxide emissions are estimated to exceed a total of 25 billion tons per year in 1995 and could reach as high as 40 billion tons per year by the year 2050. In order to mitigate this global warm up trend emissions need to be significantly curtailed. In particular, the industrialized countries' CO₂ emissions need be reduced as they presently contribute approximately 80% of total CO₂ emissions. A strong case can be presented in favor of the hydrogen fuel in meeting future world energy needs and in achieving the targeted global reduction in the CO₂ emissions. The MHR can provide the energy required for production of hydrogen.

This paper summarizes the potential non-electric application of the MHR in providing the process steam for cogeneration applications, process heat for transportation fuel production of hydrogen for various industrial applications.

2. MODULAR HELIUM REACTOR HEAT SOURCE

Efforts to enhance the nuclear energy option in the U.S. have brought about the development of a new generation of reactor designs. These advanced designs emphasize reduced complexity and passive safety in concert with economic competitiveness to modern fossil fired generation. One such advanced design is the Modular Helium Reactor (MHR). Its key characteristics of simplicity, versatility and unparalleled safety provide strong incentives for worldwide deployment as a heat source to meet diverse future energy needs.

2.1 MHR Characteristics

The MHR combines the characteristics of ceramic-coated fuel, helium coolant, graphite moderator, and a unique core configuration with passive decay heat removal capability. These characteristics have been innovatively combined to meet stringent safety requirements while at the same time offering competitive energy costs. The intrinsic properties of this combination are:

- Coated Particle Fuel - The multiple ceramic coatings surrounding the fuel kernels constitute tiny independent pressure vessels, which retain fission products. These coatings are capable of maintaining their integrity and fission product retention at temperatures much higher than those imposed during postulated extreme accident conditions.
- Helium Coolant - The inert and single phase helium coolant has several advantages: no flashing or boiling of coolant is possible, pressure measurements are certain, and pump cavitation cannot occur. Further, there are no reactivity or corrosive effects associated with helium and no potential chemical or energy reactions between coolant and fuel is possible.
- Graphite Core - The strengths of the graphite core at high temperatures results in a wide margin between operating temperatures and temperatures that would result in core damage. Further, the high heat capacity and low power density of the core result in very slow and predictable temperature transients.
- Core Configuration - Selection of an annular core geometry, low core power density, and core power level assures that fuel temperatures remain hundreds of degrees below the integrity limit of the coated particle fuel even if all active coolant circulation fails and even if the coolant were lost.
- Passive Decay Heat Removal System - In addition to the normally operating power conversion system and an independently powered shutdown cooling system, a completely passive, safety grade reactor cavity cooling system is provided.

The selection of helium as the coolant, graphite for the core structure, and ceramic fuel sets the MHR apart from other power reactors and is the cornerstone of its high temperature capability. This unique heat source enables high power conversion efficiency and a range of energy conversion alternatives. The modular helium reactors can produce helium at temperatures as high as 1000°C.

2.2 MHR Heat Source Design

The MHR heat source is located inside a reactor pressure vessel as shown in Figure 1 (Ref. 1). The reactor core is designed to provide 600 MW(t) at a power density of 6.6 MW/m³. The active core consists of an assembly of hexagonal graphite fuel elements containing nuclear fuel compacts and coolant flow channels. The active fuel region of the core is arranged in the form of an annulus as shown in Figure 2. The fuel elements are stacked in the core to form columns that rest on support structures. The annular

The core reactivity is controlled by a combination of burnable poison, movable control rods and a negative temperature coefficient. Independent and diverse reserve shutdown control is provided in the form of boronated pellets that may be released into channels in the active core.

The MHR system exhibits many key safety design features including the ceramic coated TRISO fuel, with its capability to retain fission products at very high temperatures, low power density annular core, factory fabricated steel vessels, and entirely passive decay heat removal. The release of large quantities of radionuclides is essentially precluded by the fuel particle ceramic coatings even under severe accident conditions. All the reactor system components are based on proven technology.

The MHR offers the broadest range of industrial uses of any reactor system. This attribute has been one of the driving forces behind its development. An overview of some of the applications is described in the following sections. In addition to electricity generation, the MHR can play a major role in the primary energy supply due to its unique capability to heat working fluids to 1000°C. Described below are three broad categories of MHRs for non-electric applications, first the Process Steam/Cogeneration Modular Helium Reactor (PS/C-MHR), second Process Heat Module Helium Reactor (PH-MHR), and third the Hydrogen Production Modular Helium Reactor (HP-MHR).

3. PROCESS STEAM/COGENERATION MODULAR HELIUM REACTOR

Energy requirements of industrial process complexes vary widely, according to varying steam conditions, capacity requirements, and the ratio of thermal to electric power. The high temperature/high pressure steam at 2500 psia (17.3 MPa) and 1000°F (540°C) produced by the PS/C-MHR can provide energy for heat cycles in a wide range of process applications and industrial complex sizes and capacities.

3.1 PS/C-MHR Plant Description

The P/SC-MHR is being designed to meet the rigorous requirements established by the Nuclear Regulatory Commission (NRC) and the electric utility-user industry for a second-generation power source for the late 1990s. The plant is expected to be equally attractive for deployment and operation in the United States, other major industrialized nations, and the developing nations of the world.

The most economic PS/C-MHR plant configuration includes an arrangement of several identical modular reactor units, each located in a single reactor building (Ref. 1). The plant is divided into two major areas: the nuclear island (NI), containing the several reactor modules, and an energy conversion area (ECA), containing turbine generators and other balance of plant equipment. The basic layout for a single reactor module is shown in Fig. 3. Each reactor module can be connected independently to steam turbine in or other steam utilizing systems. The nominal plant parameters are offered in Table 1.

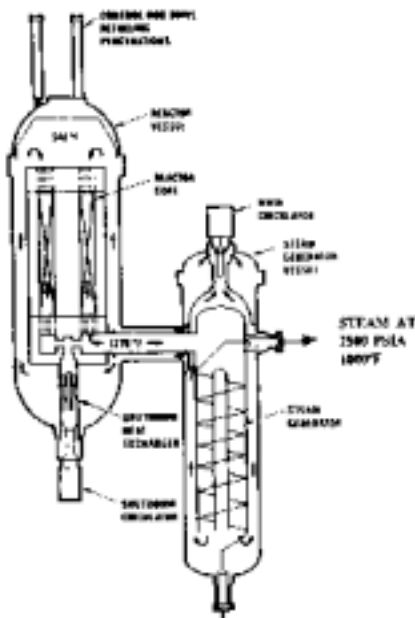

TABLE 1
PS/C-MHR PLANT PARAMETERS

Reactor Module Parameters	Recommended Design
Thermal Power, MW(t)	600
Fuel Columns	102
Fuel Cycle	LEU/Natural U
Average Power Density, W/cm ³	6.6
Primary Side Pressure, MPa (psia)	7.07 (1025)
Induced Helium Flowrate	281 kg/s
Core Inlet Temperature, °C (°F)	288(550)
Core Outlet Temperature, °C (°F)	704(1300)
Steam Temperature, °C (°F)	541(1005)
Steam Pressure, MPa (psia)	17.3(2515)
Circulator Power, MW(e)	6.0

The reactor module components are contained within three steel pressure vessels; the reactor vessel, a steam generator vessel, and connecting cross vessel. The uninsulated steel reactor pressure vessel is approximately the same size as that of a large boiling-water reactor and contains the core, reflector, and associated supports. The reactor core and the surrounding graphite reflectors are supported on a steel core support plate at the lower end of the reactor vessel. Top-mounted penetrations house the control-rod drive mechanisms and the hoppers containing boron carbide pellets for reserve shutdown. The core layout for this 600 MW(t) design is shown in Figures 1 and 2 and described earlier in Section 2.2.

The heat transport system (HTS) provides heat transfer during normal operation or under normal shutdown operation using high pressure, compressor driven helium that is heated as it flows down through the core. The coolant flows through the coaxial hot duct inside the cross vessel and downward over the once through helical bundle steam generator. Helium then flows upward, in an annulus, between the steam generator vessel and a shroud leading to the main circulator inlet. The main circulator is a helium submerged, electric-motor-driven, two-stage axial compressor with active magnetic bearings. The circulator discharges helium through the annulus of the cross vessel and hot duct and then upward past the reactor vessel walls to the top plenum over the core.

For availability and maintenance requirements, a separate shutdown cooling system (SCS) is provided as a backup to the primary HTS. The shutdown heat exchanger and shutdown cooling circulator are mounted on the bottom of the reactor vessel. The heat removal systems allow hands-on module maintenance to begin within 24 hours after plant shutdown.

The reactor cavity cooling system (RCCS) is located in the concrete structure external to the reactor vessel to provide a passive heat sink to remove residual heat from the reactor cavity if the HTS and SCS are unavailable to perform their intended functions. The RCCS consists of above-grade intake structures that naturally convect outside air down through enclosed ducts and panels that surround the below-grade core cavity before returning the warmed air through above-grade outflow structures. The core heat is transferred by conduction, convection, and radiation from the core to the RCCS. This system has no controls, valves, circulating fans, or other active components and operates continuously during normal operation and during shutdown conditions.

Major cogeneration applications are highly energy intensive and diverse, including such processes as those associated with heavy oil recovery, tar sands oil recovery, coal liquefaction, coal gasification, steel mill and aluminum mill processes. Use of MHR in each of these processes has been studied at General Atomics and summarized below.

3.2 Heavy Oil Recovery

About 15% of the U.S. domestic oil reserves are in the form of heavy crude oil, defined as having an American Petroleum Institute (API) gravity of $<20^\circ$. Recovering this heavy oil can be greatly improved by stimulation methods, such as steam injection. This section summarizes a study (Ref. 2) to apply 2x600 MW(t) PSIC MHR to recovering heavy oil.

The thermal energy requirements for recovering heavy oil with steam drive depend on the oil field size and the reservoir characteristics. This study based the field size on a 2x600 MW(t) PS/C-MHR providing steam for well injection, dewatering, and other process facilities and cogenerating electric power for on-site and off-site uses.

Figure 4 shows a typical field arrangement for a heavy oil recovery project using steam from a Modular Helium Reactor. If injection wells are spaced 1 m^2 (2.5 acres) apart (average), $\sim 698 \text{ m}^2$ (1725 acres) of heavy oil field may be operated at a time with 2x600 MW(t) PS/C-MHR. Typically, the well injection head injects steam at $\sim 3.4 \text{ MPa}$ (500 psia), which is sufficient to reach depths down to 366 m (2300 ft).

However, in some locations, the reservoir characteristics and overburden thickness require injection pressures up to 4.5 MPa (650 psia). Presently, heavy oil (steam drive) operators use steam at ~80% quality (dry) to hold dissolved solids in solution. Studies have shown that the oil yield increases significantly with the steam quality. With a PS/C-MHR, which can deliver steam in excess of 538°C (1000°F), dry saturated steam can be injected into the well if desired.

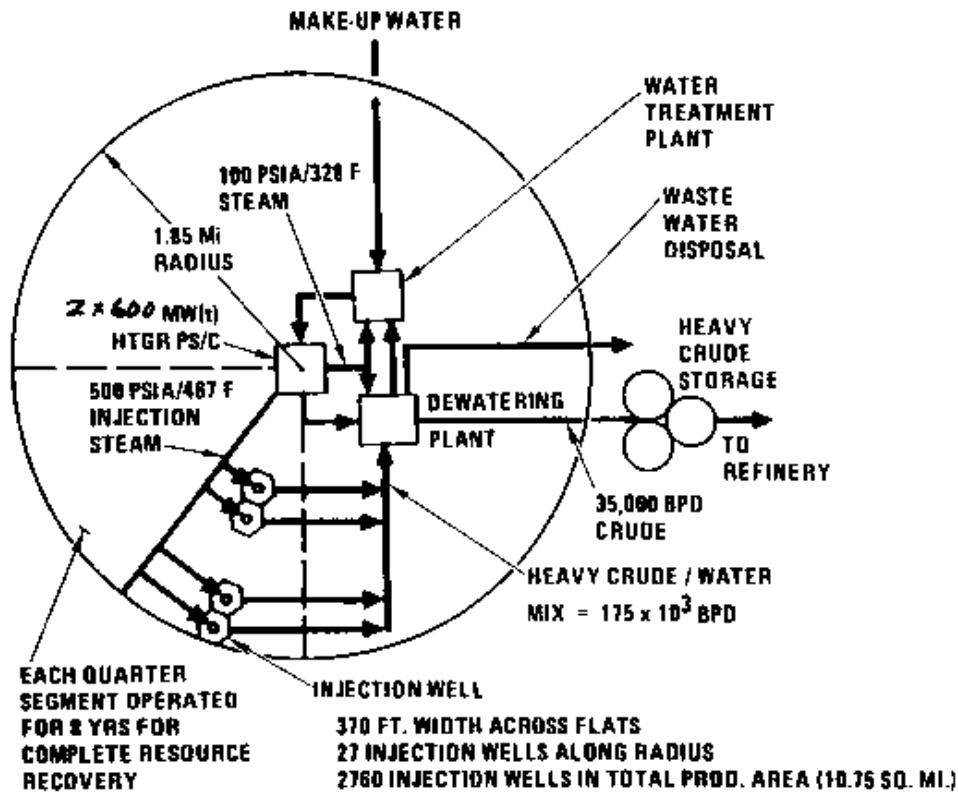

Fig. 4. Field Arrangement for 5562 m³ (35,000 barrel) per Stream Day Heavy Oil Recovery Application

As discussed above, the steam conditions desired at the injection wells are 3.45 MPa (500 psig) with 85% or higher quality, and very little electrical power is required for the oil field operations. This design approach adapts the 2x600 MW(t) PS/C-MHR.

Figure 5 shows a typical heat cycle for heavy oil recovery. First, 538°C/16.65 MPa (1000°F/2415 psia) steam from the PS/C-MHR steam generators expanded through a turbine generator to an intermediate distribution pressure for the oil field injection wells. Part of the exhaust steam from this turbine generator is then expanded through an extraction turbine generator to provide steam for feedwater heating and to produce additional cogenerated electric power. For this study, the heat cycle was designed to produce the maximum process steam output consistent with efficient cogeneration of electrical power and feedwater heating requirements. Less process steam and more electrical power can be achieved by adding condensing turbine generator capacity; this would be desirable for specific oil field applications with attractive nearby electric power markets.

The heat cycle conditions the main turbine generator exhaust steam by desuperheating before distribution to the injection wells. The amount of desuperheating can be adjusted to suit specific oil fields or different periods during the oil field production life.

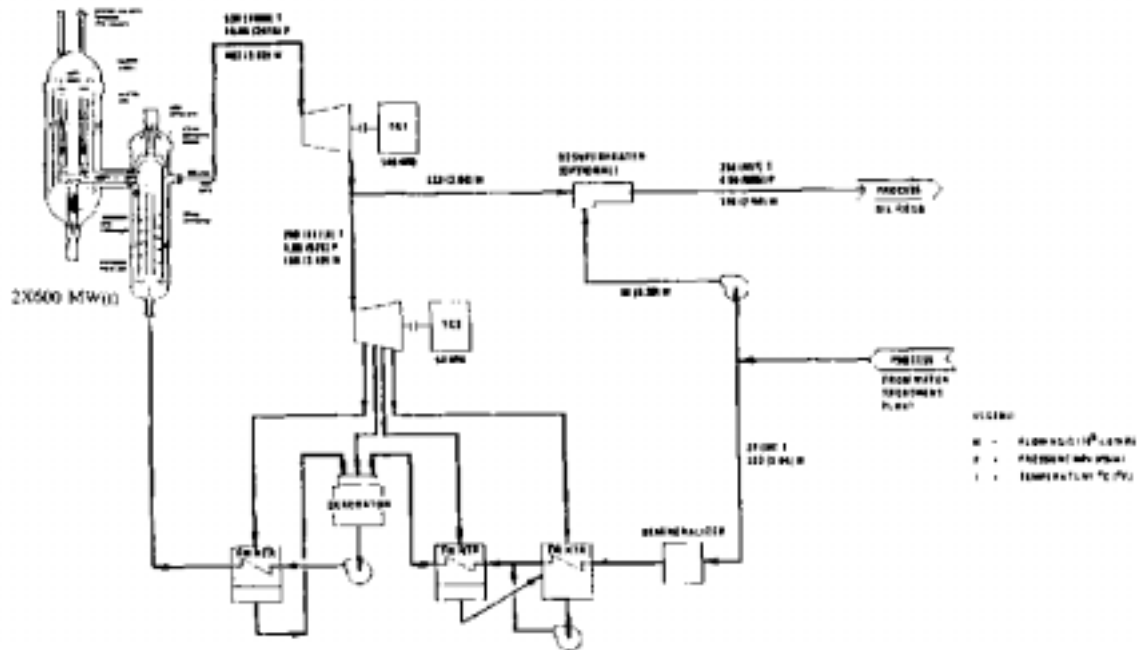

Fig. 5. Cycle Diagram for 2x600 MW(t) PS/C-MHR Plant for Heavy Oil Recovery Application

3.3 Tar Sands Oil Recovery

Tar sands represent a major energy resource that increases in importance as world supplies of crude oil become limited. The oil potential from tar sands in Canada is estimated to equal the world's known reserves of conventional oil; the potential of U.S. tar sands is smaller, but still substantial [4.8 to 5.6×10^9 m^3 (30 to 35×10^9 bbl)]. Current Canadian production is limited to deposits suitable for strip mining; however, the major reserves lie at greater depths. To exploit these deep reserves, large-scale pilot projects have investigated in-situ recovery. These projects inject saturated steam into the tar sands deposits.

This section summarizes a study (Ref. 3) to apply 2x600 MW(t) PS/C-MHR to tar sands oil recovery and upgrading. The raw product recovered from the sands is a heavy, sour bitumen; upgrading, which involves coking and hydrodesulfurization, produces a synthetic crude (refinable by current technology) and petroleum coke. Steam and electric power are required for the recovery and upgrading process.

The tar sands fields are generally located in sparsely populated areas of Canada. Therefore, the PS/C-MHR plant can be located at the center of the recovery area, minimizing the required piping and the associated pressure drops and heat losses. When the recovery is complete in one quarter of the operating field, the piping will be shifted to the next quarter until the entire field has been covered. Since it takes -7 years to complete each quarter of the field, the PS/C-MHR will have operated most of its design life (30 years) by the time the recovery is complete.

The nominal steam conditions desired at the injection well are 13.8 MPa (2000 psia) and 336°C (636°F). Since this steam is obtained by throttling the main steam from 16.65 MPa (2415 psia), adjusting the pressure to account for variations in the distribution pressure drop has some flexibility. A desuperheater using returned water reduces the steam temperature to the saturated condition. The steam required for upgrading, water treatment, and auxiliaries can be further conditioned as required. The balance of the steam, not used by the process, is diverted to a turbine generator, which cogenerates electric power and provides a conventional feedwater heating system for the entire condensate flow. The recovery plant processes makeup and clean condensate. To ensure the specified purity for the PS/C-MHR steam generators, the feedwater train includes a full-flow polishing demineralizer.

Figure 6 shows the cycle for the 7309 m^3 /day (46,000 bpd) plant. In this case, only enough steam for feedwater heating [147 kg/s (1.16×10^6 lb/hr)] is diverted to the turbine generator; the recovery plant uses the balance [439 kg/s (3.48×10^6 lb/hr)]. The turbine generator is a noncondensing unit similar to the high pressure and intermediate pressure units of a small conventional turbine generator; its gross output is 101 MW(e), while its net output is 64 MW(e). The difference is used to drive the PS/C-MHR circulators, the feed pumps, the condensate pumps, and other nonprocess auxiliaries.

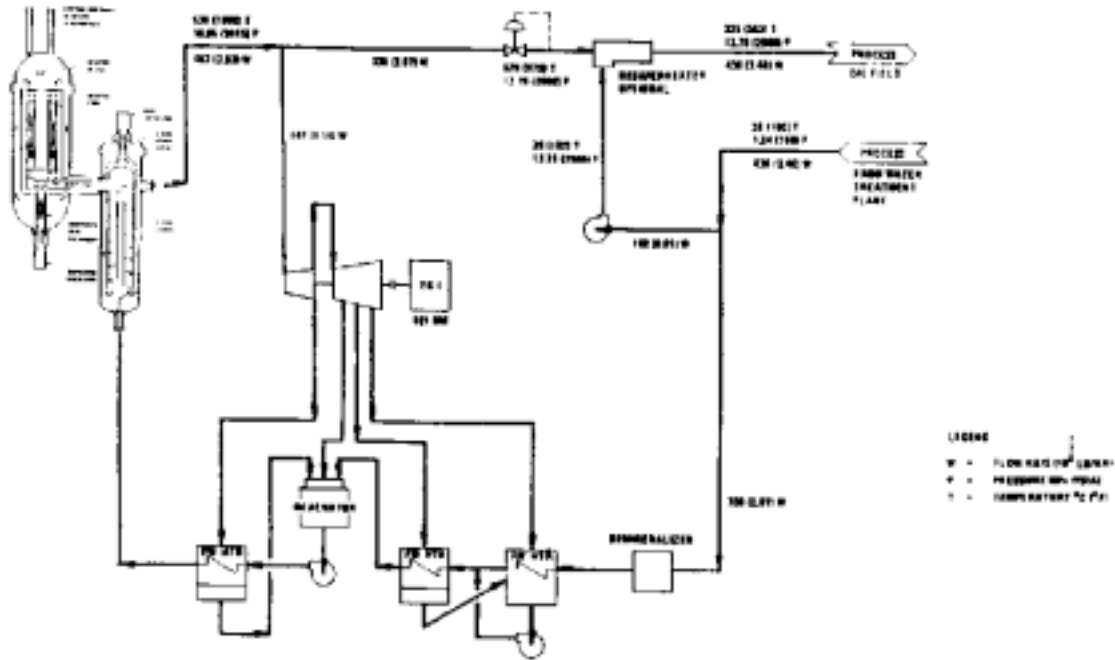

Fig. 6. Cycle Diagram for 2x600 MW(t) PS/C-MHR for Tar Sands Oil Recovery Application

3.4 Coal Liquefaction

The solvent refined coal (SRC-II) process is an advanced process developed by Gulf Mineral Resources Ltd. to produce a clean, nonpolluting liquid fuel from high sulfur bituminous coals. The SRC-II commercial plant will process -24,300 tonnes (26,800 tons) of feed coal per stream day, producing primarily fuel oil and secondary fuel gases. This summary describes (Ref. 4) the coupling of two module 600 MW(e) PS/C-MHR to the SRC-II process.

Figure 7 shows the SRC-II process flow diagram and gives the steam conditions at various process stages. It shows that the process steam is generated by direct gas-fired boilers, and the process heating by direct gas firing. The fuels utilized are hydrocarbon-rich gas, or CO-rich gas, and purified syngas (i.e., no feed coal is used for fuel). It was shown that a 2x600 MW(t) PS/C-MHR can supply these thermal requirements principally by substituting for the fuel gases previously employed. The displaced gases, which are treated already, may then be marketed.

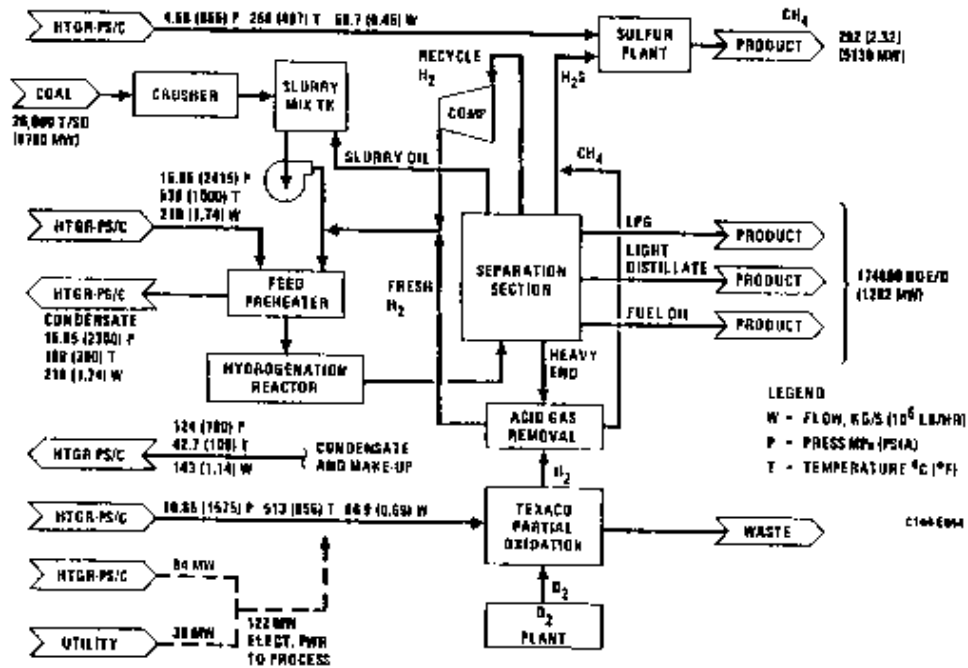

Fig. 7. Process Flow Diagram for SRC-II Coal Liquefaction Application Using 2x600 MW(t) PS/C-MHR

The 538°C (1000°F) steam supply of the PS/C-MHR provides all system thermal energy requirements in the form of process steam generation, steam superheating, and slurry heating. However, slurry heating by steam will entail the development of a new heat exchanger design. The 2x600 MW(t) PS/C-MHR does not generate all the required electrical energy, and a deficit of ~38 MW(e) results.

Figure 8 shows the PS/C-MHR plant cycle diagram. The 10.45 MPa (1515 psia) steam is supplied by throttling the main steam from 16.65 MPa (2415). After throttling, the steam temperature is 513°C (9560P). The required 4.58 MPa (665 psia) saturated steam is supplied from the high-pressure turbine exhaust, which is desuperheated using returned condensate. The remaining four heat requirements are supplied by main steam through separate heat exchangers. The high-pressure condensate from these heaters at 15.86 (2300 psia) and 199°C (390°F) is mixed with the other feedwater between the boiler feed pump and the top feedwater heater.

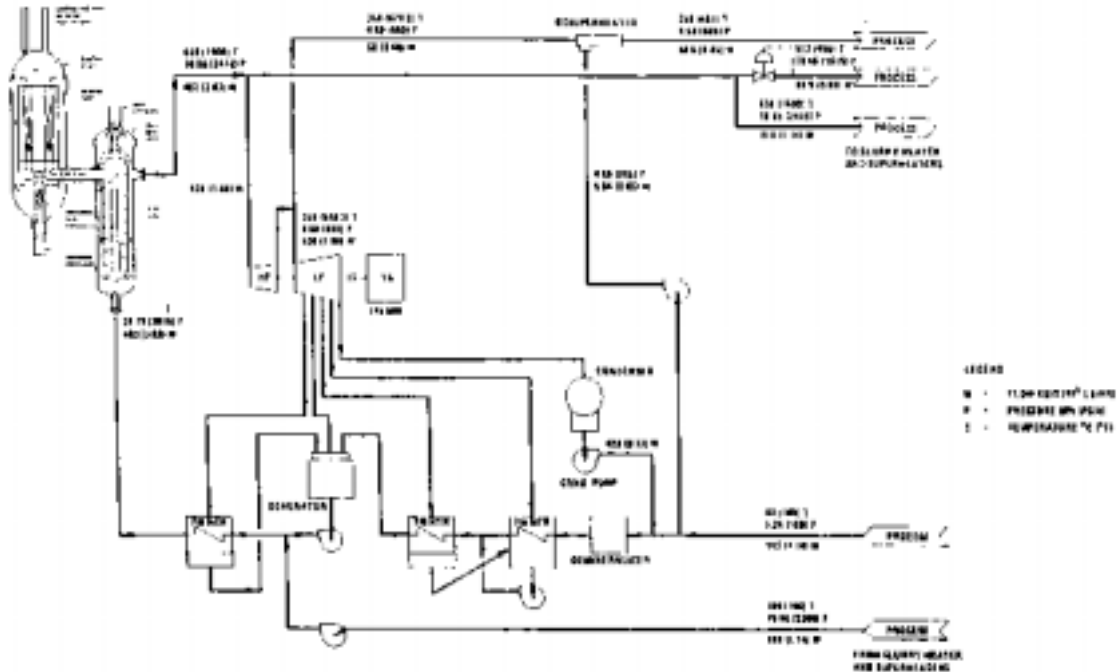

Fig. 8. Cycle Diagram for 2x600 MW(t) PS/C-MHR for SRC-II Coal Liquefaction Application

All the SRC-II plant steam and heat requirements are satisfied either directly or through the heat exchangers. Other steam supplies a condensing steam turbine generator, which produces 114,532 kW and heats all the feedwater for return to the steam generators. The net plant output is 83,509 kW(e).

3.5 H-Coal Liquefaction Process

In countries of large, coal reserves, a strong interest exists to develop and commercialize plants producing liquid and gaseous synthetic fuels derived from coal because of the national objective to reduce foreign oil imports or to export liquid coal. The H-Coal liquefaction is one process, which can be used to convert coal into liquid fuel. This section summarizes a study (Ref. 5) to apply a 2x600 MW(t) PS/C-MHR to this process, based on a plant capacity of 27,200 tonnes (30,000 tons) per stream day.

The H-Coal process has several advantages over other processes, including an isothermal reactor bed, hydrogenation of the coal with a direct, continuously replaceable catalyst (i.e., no dependence on catalytic effects of coal ash), and the absence of quench injections (which would be required with a series of fixed beds).

Figure 9 shows the process flow diagram for a 27,200 tonnes per stream day H-Coal commercial plant using an integrated 2x600 MW(t) PS/C-MHR as the energy source. The original H-Coal process employs mostly coal as its utility fuel, supplemented by high Btu gas from the product stream. Process electric power [251 MW(e)] is purchased from the grid. About 1,090 tonnes (1200 tons) per stream day of coal is required as utility fuel to provide both process heat and process steam. With an integrated PS/C-MHR plant, process heat is provided by using 16.65 MPa (2415 psia) primary steam at 538°C (1000°F) as the

Figure 10 shows the heat cycle developed to meet the application requirements. Main steam at 538°C (1000°F) and 16.65 MPa (2415 psia) supplies process heat to the H-Coal reactor feed preheater. High-pressure condensate from the feed preheater at 210°C (410°F) and 15.86 MPa (2300 psia) then cascades through the fluidized bed dryer and returns to the PS-C-MHR feedwater heating system at 24°C (75°F) and 15.51 MPa (2250 psia). Additional main steam is throttled and desuperheated to 319°C (606°F) and 11.14 MPa (16/15 psia) to supply steam to the Texaco partial oxidation reaction unit. The remainder of the steam from the PS/C-MHR is expanded through a condensing turbine generator, which produces 217 MW(e) gross and provides extraction steam for feedwater heating.

Condensate and makeup water are assumed to return from the process at 43°C (109°F) and 1.20 MPa (180 psia). Part of this water supplies desuperheating water via a booster pump. The remainder is combined with water from the turbine generator condenser hotwell, then passes through a conventional three-stage feedwater heating train. A separate high-pressure feedwater train heats condensate from the fluidized bed dryer unit. Feed pump discharge from the two trains is combined and passes through an additional high-pressure feedwater heater before returning to the PS/C-MHR steam generators at 221°C (430°F) and 20.79 MPa (3015 psia).

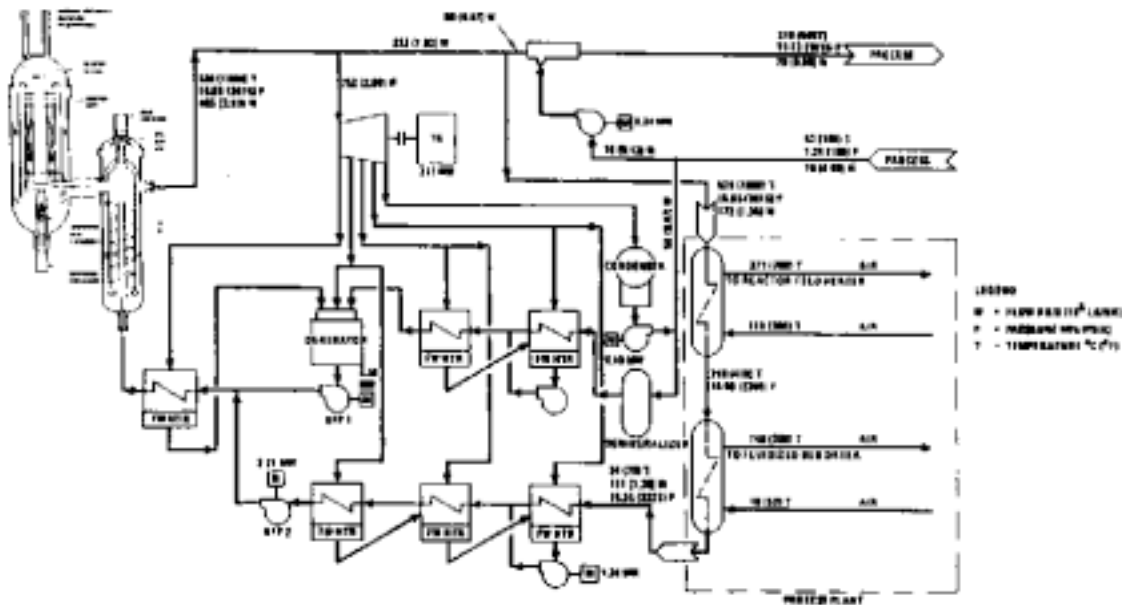

Fig. 10. Cycle Diagram for 2x600 MW(t) PS/C-MHR for H-Coal Process Application

3.6 Coal Gasification Process

This section summarizes a study to apply the PS/C-MHR to Exxon catalytic coal gasification. Several countries worldwide are interested in developing plants producing gaseous synthetic fuels derived from coal, based on the national objective to reduce foreign oil imports and to use or export the abundant coal. Exxon catalytic coal gasification (ECCG) is one gasification process developed in the United States.

Initially, coal gasification plants are expected to obtain thermal power requirements from fossil sources (coal or product liquid and gaseous fuel from the synfuel plant) and to obtain electric power partly from in-plant cogeneration and partly from local utilities. Most processes are estimated to consume 25% to 30% of the feed coal to satisfy the plant energy needs.

This study (Ref. 6) indicates that incorporating a PS/C-MHR plant could provide thermal and electrical energy for the ECCG process to benefit worldwide interests by conserving fossil fuel and reducing environmental impact.

The ECCG process uses alkali metal salts as a gasification catalyst with a novel processing sequence. Although no net heat is required for the gasification reaction, heat input is required for drying and preheating the feed coal, gasifier heat losses, and catalyst recovery operations. Mechanical drives and plant electrical power also have energy input requirements. Figure 11 plots heat input versus temperature for the process, and indicates which can be provided by the PS/C-MHR.

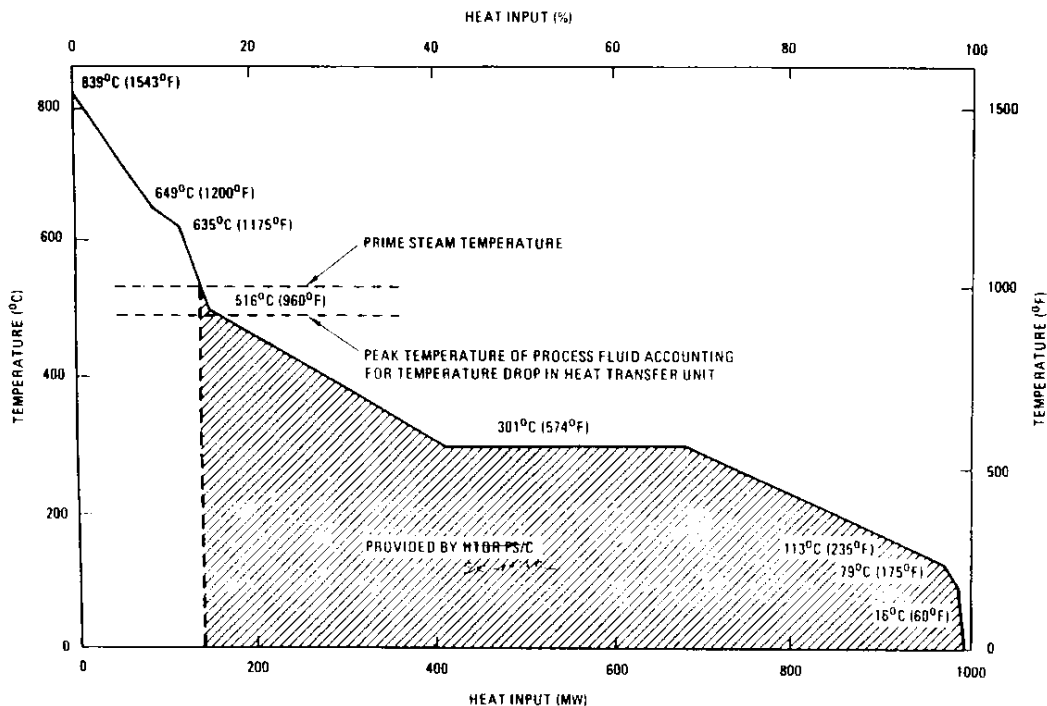

Fig. 11. Heat Input Temperature Distribution for ECCG Process Using 2x600 MW(t) PS/C-MHR

Figure 12 shows a conceptual arrangement for an ECCG process plant using energy from two module 2x600 MW(t) PSIC-MHR. About 13,144 tonnes (14,490 tons) of coal per stream dry (wet basis) are processed, and the plant produces ~6833 m³/day (~43,000 bpd) oil equivalent product (3140 MW) as methane.

As indicated above, the PS/C-MHR can supply all energy requirements for the ECCG process, except for very high-temperature energy required to preheat feed to the gasification reactor. This is assumed to be supplied by fossil-fired heaters. Two 600 MW(t) PS/C-MHR provides energy sufficient for the remaining process heat and mechanical power requirements and all plant electrical power requirements for the 13,144 tonnes (14,490 tons) per stream day ECCG plant considered in this study. In addition, surplus electrical power produced is available for other uses.

This brief study shows that the PS/C-MHR appears to make a good fit with the ECCG process.

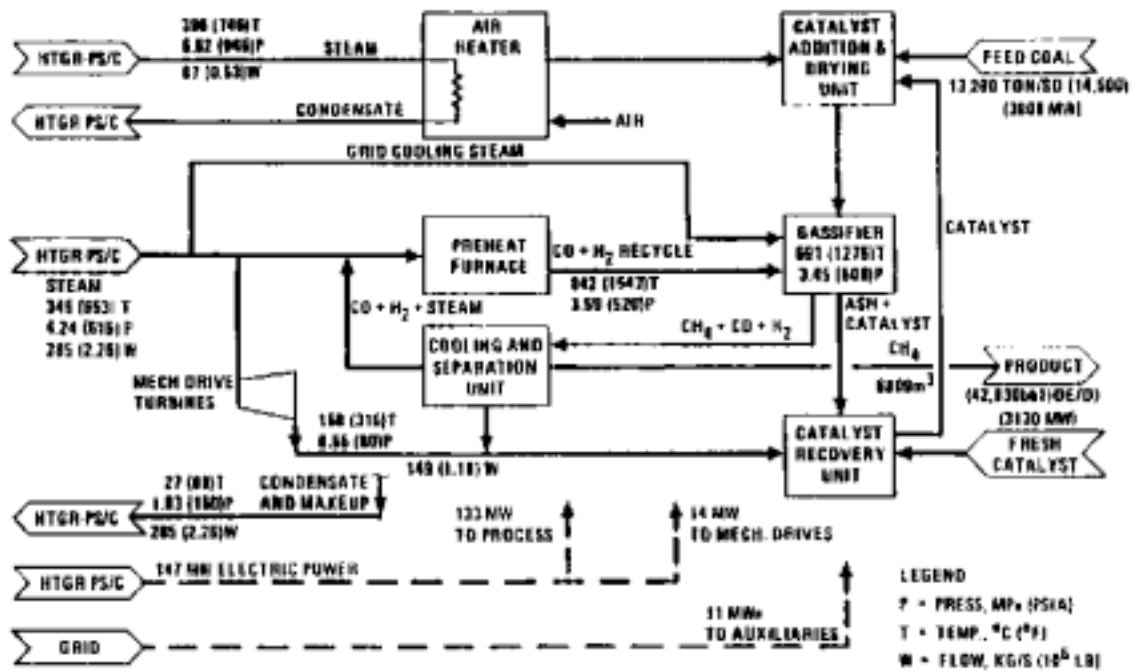

Fig. 12. Process Flow Diagram for ECCG Power Application Using 2x600 MW(t) PS/C-MHR

Figure 13 shows the proposed heat cycle. The high-pressure turbine, which exhausts at 4.4 MPA (640 psia), is similar to the high-pressure unit of a 450-MW turbine generator, except that a controlled extraction at 6.5 MP A (945 psia) provides steam for air preheating. The exhaust steam, is split: 136 kg/s (1,080,000 lb/hr) goes to the process, sufficient steam is provided to the feedwater heating extraction turbine, and the remainder is used in noncondensing mechanical drive turbines. The feedwater heating turbine is a noncondensing unit similar to portions of a conventional power plant intermediate/low pressure turbine. The backpressure on this unit is set at 58 kPa (8.42 psia) to suit feedwater heating requirements.

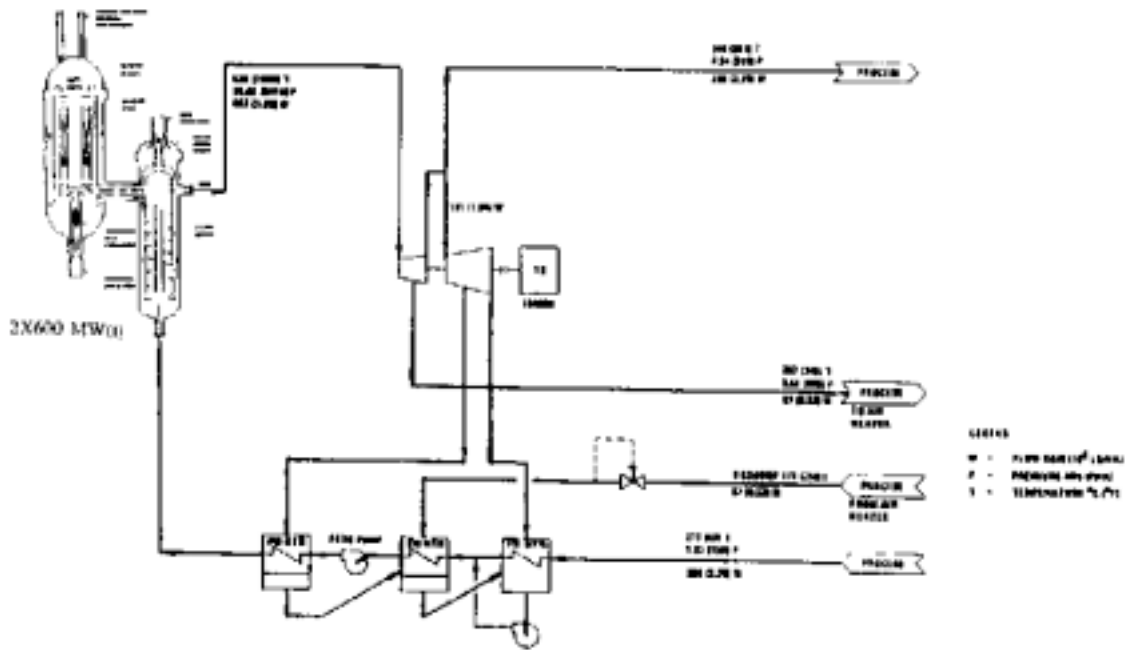

Fig. 13. Cycle Diagram for 2x600 MW(t) PS1C-MHR for ECGG Process Application

3.7 Steel Mill

The U.S. steel industry is very large and consumes large quantities of energy. It uses ~35% of this energy in the form of electricity, fuel oil, or natural gas; the balance is coal. Therefore, the supply of the non-coal energy by a PS/C-MHR can conserve scarce fossil fuel resources.

This section summarizes a study (Ref. 7) to apply two module 600 MW(t) PS/C-MHR to a 6.5×10^6 tonnes (7.2×10^6 tons) per year liquid steel plant. The SC-MHR can provide both electricity and high- temperature steam to flexibly meet steel mill needs and provide export electricity to the local utility grid.

The 2x600 MW(t) PS/C-MHR can satisfy the energy requirements for a typical commercial steel mill to produce 6.5×10^6 tonnes (7.2×10^6 tons) (liquid) of steel per year. The surplus energy, which may be generated either as steam at 5.0 MPa (725 psia) and 365°C (689°F at 125 kg/s (10^6 lb/hr) or as electric power [~ 100 MW(e)], can be exported outside the plant. Depending on the steel mill location, steam could be supplied to neighboring industries or, alternatively, the electric power can be sold to a utility.

The plant design is based on the two module PS/C-MHR. Two cases were considered:

- Case 1:** Supply 240,000 kW and 101 kg/s (800,000 lb/hr) of steam to the steel mill with excess energy used to supply additional steam to other users at the same conditions.
- Case 2:** Supply 240,000 kW and 101 kg/s (800,000 lb/hr) of steam to the steel mill with excess energy used to generate additional electric power.

Figures 14 and 15 give the cycles selected to satisfy the requirements for the two cases, respectively.

For Case 1, 101 kg/s (800,000 lb/hr) of steam is supplied to the steel mill: in addition, 135 kkg/s (1,068,000 lb/hr) of steam is provided to other users. The net electrical power produced is 240,000 kW.

For Case 2, only 101 kg/s (800,000 lb/hr) of steam is produced and supplied to the steel mill, and the net electrical power produced is increased to 354,558 kW.

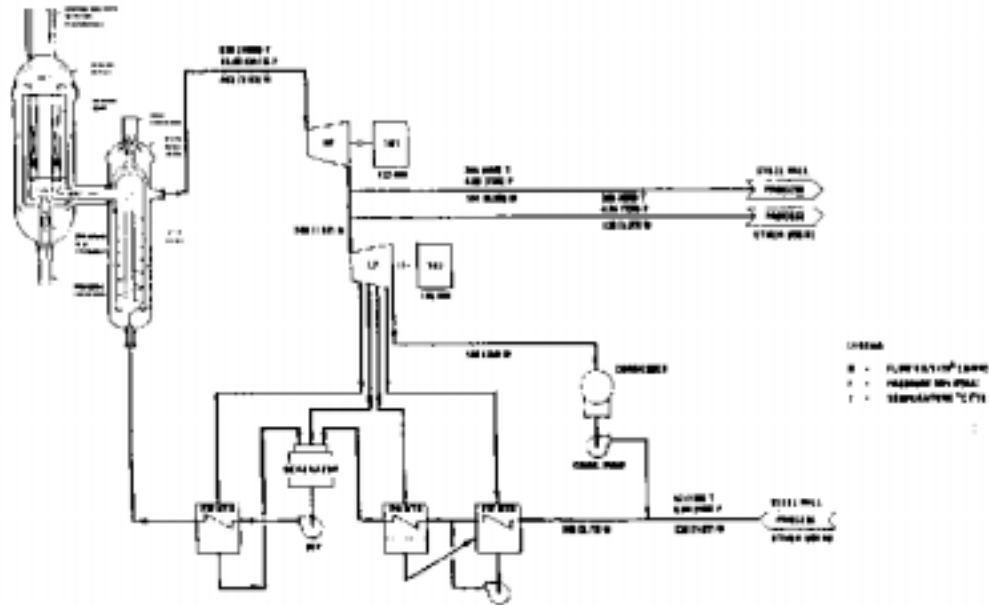

Fig. 14. Cycle Diagram for 2x600 MW(t) PS/C-MHR Plant for Steel Mill Application (Tailored Cogenerated Electrical Power)

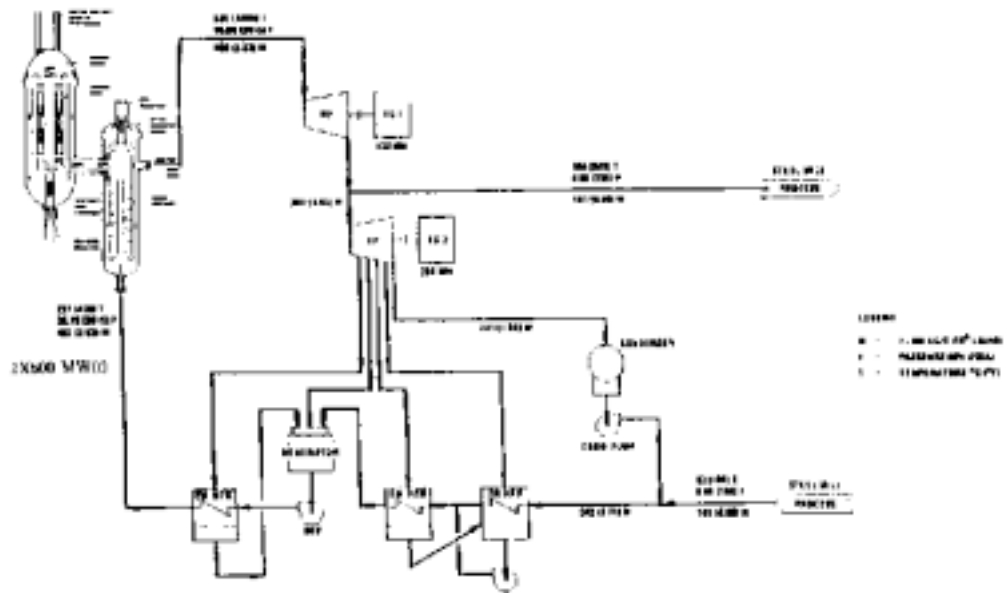

Fig. 15. Cycle Diagram for 2x600 MW(t) PS/C-MHR Plant for Steel Mill Application (Maximum Cogenerated Electrical Power)

3.8 Alumina Plant

Aluminum refining uses two major energy-intensive processes:

1. Aluminum oxide or alumina is obtained from bauxite via the Bayer chemical process. This process uses a significant amount of steam to react with bauxite and for mechanical drive. It also requires electric power.
2. Alumina is reduced to aluminum by electrolysis. This process requires large amounts of electric power.

Figure 16 shows a schematic process flow diagram from ore reduction to aluminum production. Most existing commercial aluminum plants use energy from natural gas power plants. Hydroelectric power supplies a very small fraction of the total aluminum electric power requirements.

This section considers (Ref. 8) the PS/C-MHR application to producing alumina from bauxite. For the size alumina plant considered, the two module 600 MW(t) PS/C-MHR supplies 100% of the process steam and electrical power requirements and produces surplus electrical power and/or process steam, which can be used for other process users or electrical power production. Presently, the bauxite ore is reduced to alumina in plant geographically separated from the electrolysis plant. However, with the integration of 2x600 MW(t) PS/C-MHR units in a commercial alumina plant, the excess electric power available [~ 233 MW(e)] could be used for alumina electrolysis.

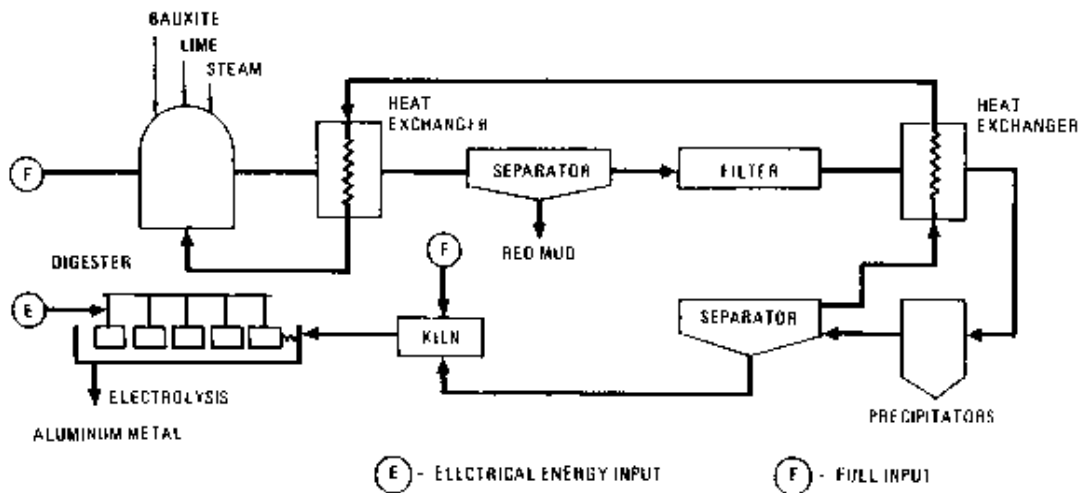

Fig. 16. Process Flow Diagram for Aluminum Mill Application

It has been shown the steam and electrical energy requirements for a typical commercial alumina plant processing 726,680 tonnes (800,000 tons) per year of alumina (Al_2O_3) can be satisfied by two module PS/C-MHR.

A two module PS/C-MHR has excess capacity for the process steam and electrical power requirements of the 725,680 tonnes (800,000 tons) per year alumina plant considered in this study. The excess capacity can produce additional process steam for sale to other users, additional electrical power for sale to a utility or for use by the alumina electrolysis plant, or any desired combination of excess steam and electric power. The local market for other process steam uses, plant economics, proximity of the electrolysis plant, etc., would determine the cycle selected. Two limiting heat cycles have been studied: (1) maximum process steam (Fig. 17) and (2) maximum cogenerated electric power (Fig. 18).

The plant entry should have nominal steam conditions of ~ 4.96 MPA/ $321^\circ C$ (720 psia/ $610^\circ F$; some variation is acceptable. The cycles studied produce steam at 5.45 MPA/ $381^\circ C$ (790 psia/ $718^\circ F$) at the reactor plant site boundary, providing a margin for transmission losses. The alumina plant can provide additional steam conditioning by throttling and/or desuperheating as required.

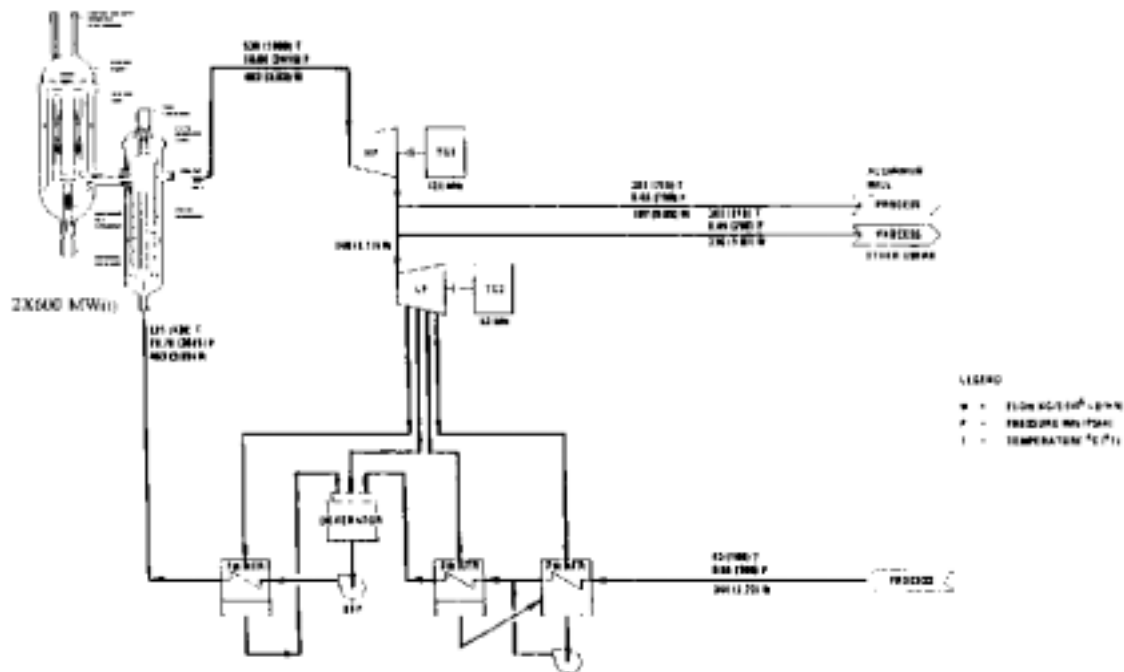

Fig. 17. Cycle Diagram for 2x600 MW(t) PS/C-MHR Plant for Aluminum Mill Application (Maximum Process Steam)

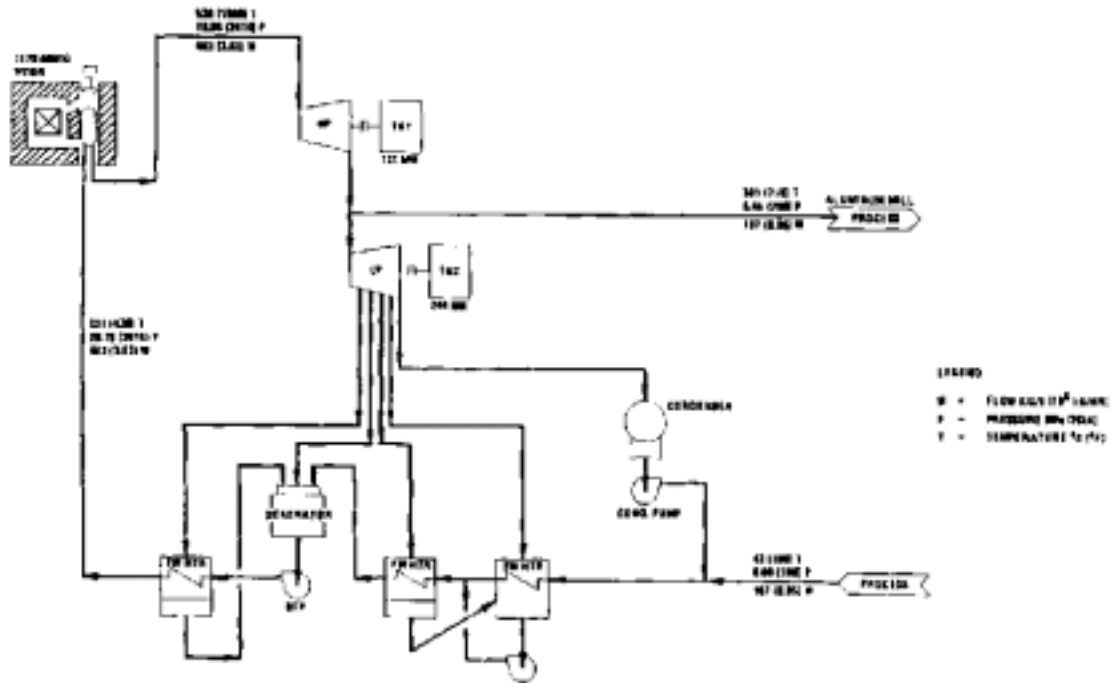

Fig. 18. Cycle Diagram for 2x600 MW(t) PS/C-MHR Plant for Aluminum Mill Application (Maximum Electrical Power)

4. PROCESS HEAT APPLICATIONS

High temperature process heat is a second major example (Ref. 9) how the MHR can be extended to use its full temperature capability in non-electric applications. In terms of market application, transportation fuels represent the largest potential application for a Process Heat Modular Helium Reactor (PH-MHR) system. Potential fuels could include methane, synthetic gasoline or hydrogen itself using various feedstocks. However, one interesting application is the production of methanol from coal.

The principal challenge to configuring a PH-MHR system for methanol production is the method of transporting heat to drive the coal to methanol reactions. Nuclear heat must be generated separately and then studied indirectly to the process steam by a heat exchanger. Two possible configuration arrangements have been studied for nuclear coal conversion schemes, steam-coal gasification and hydrogasification (Ref. 5). The preferred process for this study is hydrogasification, which has the advantage of requiring only one heat exchanger interface, a reformer, between the nuclear heat source and the coal conversion process system. The basic reactions for the hydro- gasification process are shown in Figure 19 and the process arrangement is shown in Figure 20.

In a hydrogasification process, nuclear generated heat is introduced directly through the reformer, which converts CH₄ and steam to CO and H₂. For efficient reaction rates, the former requires heat at temperatures up to 788°C (1450°F), which is achievable with an MHTGR-PH with an 850°C (1562°F) core outlet helium temperature. In addition, feed steam is required at approximately 482°C (900°F) in at least 2-to-1 ratio with CH₄. This high temperature steam can be conveniently supplied by a steam generator in series with the reformer.

4.1 PH-MHR Plant Description

The proposed physical configuration of the PH-MHR for methanol production is a straight-forward adaptation of the PS/C-MHR design. Figure 21 shows the configuration of the 600 MW(t) PC-MHR primary system with the reactor in one vessel and the heat exchangers and circulator in a second vessel viz. the MHTGR-SC arrangement. Primary coolant exiting from the core at 850°C (1562°F) flows through the inner duct in the cross-vessel to the heat exchanger vessel where it gives up its heat in series to the reformer and the steam generator. The circulator, which is located at the top of the heat exchanger vessel, returns the cold helium at 343°C (650°F) to the core inlet via the outer concentric duct.

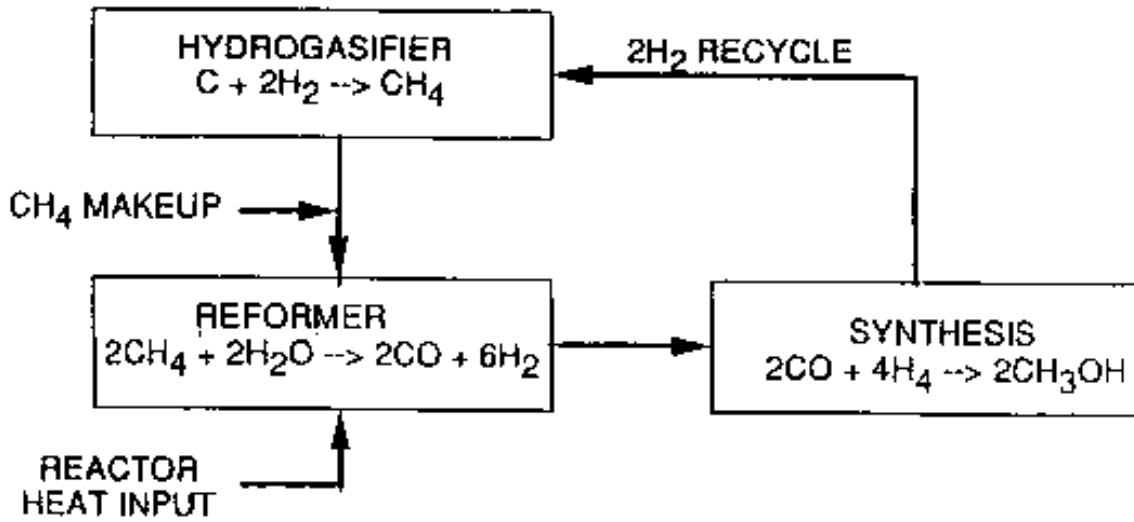

Fig. 19. Reactions for Coal to Methane by Hydrogasification

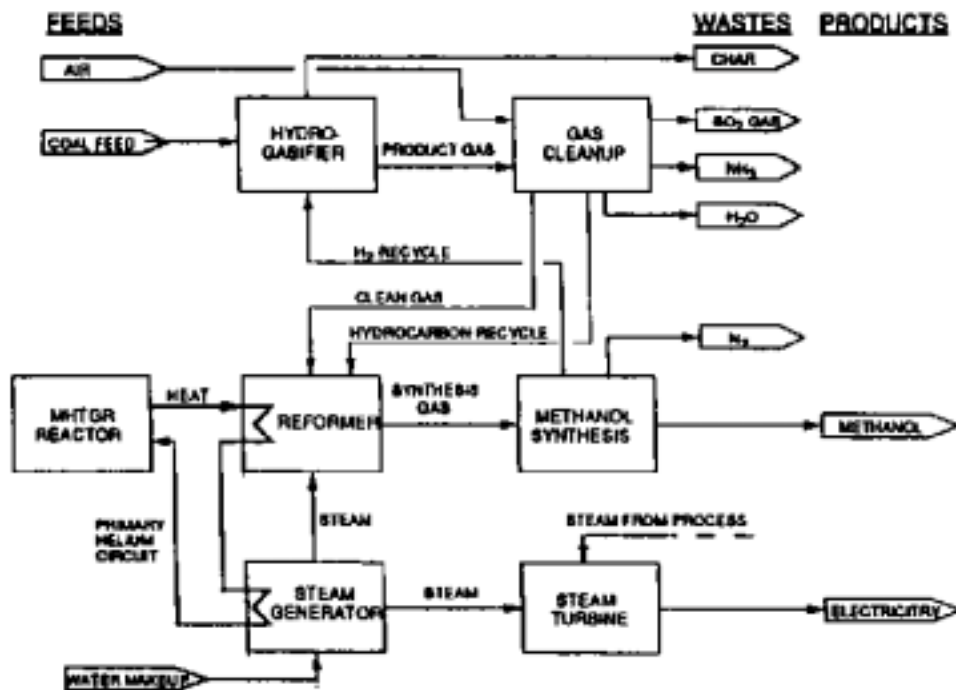

Fig. 20. Process Flow Diagram for Methanol Process Using PH-MHR Reactor Plant

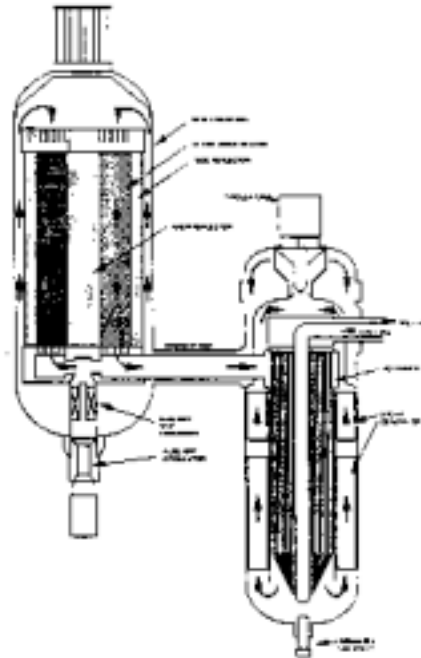

Fig. 21. PH-MHR Primary System Flow Diagram

Like the SC-MHR, the two-vessel system is located in a below-grade confinement structure with air-cooled heat removal panels to provide passive cooling of the reactor vessel for safety-related shutdown cooling events. The salient primary system design parameters for the PH-MHR are given in Table 2.

TABLE 2

PH-MHR PRIMARY DESIGN PARAMETERS

Reactor thermal power, MW(t)	600
Core inlet pressure, MPa (psia)	7.066 (1025)
Helium flow, 103 kg/s (lb/hr)	231 (1832)
Core inlet temperature, °C (°F)	343 (650)
Core outlet temperature, °C (°F)	850 (1562)
Steam generator inlet temperature, °C (°F)	676 (1248)
Steam generator outlet temperature, °C (°F)	340 (644)

The PSIC-MHR reactor can be adapted to process heat application with an outlet temperature of 850°C (1562°F) with very little modification. The most significant difference for the PH-MHR is that the fuel cycle is changed from a staggered reload scheme where half of the core is replaced every 18 months to a batch reload in which the entire core is replaced every 36 months. The effect of the batch core is to reduce the age component of the radial peaking factor and thereby reduce peak fuel temperatures.

4.2 Methanol Production

The heat exchanger arrangement (Fig. 19) is unique in that the straight tube reformer is located in the center of the helical steam generator. The hot helium from the core outlet flows down through the reformer and then up through the steam generator. Regenerative heating between the two units is limited by two shrouds and a gap.

The straight -tube reformer bundle is headered on the top by a tubesheet and on the bottom by a cylindrical manifold which is an extension of the central return duct. The large tubes, 7.6 cm (3 in.) OD, contain a nickel impregnated aluminum oxide catalyst in the form of 1.3 cm (0.5 in.) spheres for catalyzing the steam-methane reaction.

The helical steam generator surrounds the straight tube reformer. The steam generator is a down- flow unit, which represents a major deviation from the MHTGR-SC design. Downflow helical bundles have been successfully built and operated in gas-cooled reactors (viz. THTR in Germany).

Reference 10 gives a description of the methanol-from-coal process system. The process features the reformer, hydrogasifier, gas cleanup system and methanol synthesizer. Excess steam from the steam generator (which is not used in the process) is used to generate electric power as a byproduct. The primary process feed is coal and methane is used as a secondary process feed to balance the stoichiometry and eliminate production of CO₂ as a byproduct.

For a typical bituminous coal, a 4x600 PH-MHR plant requires 324,000 kg/hr coal and 75,600 kg/hr methane feeds and produces 446,000 kg/hr of methanol product along with 408 MW (e) of net saleable power.

5. HYDROGEN PRODUCTION MODULAR HELIUM REACTOR (HP-MHR)

Global carbon dioxide emissions are estimated to exceed a total of 25 billion tons per year in 1995 and could reach as high as 40 billion tons per year by the year 2050. In order to mitigate this global warm up trend emissions need to be significantly curtailed. In particular, the industrialized countries, CO₂ emissions need be reduced as they presently contribute approximately 80% of total CO₂ emissions. A strong case can be presented in favor of the hydrogen fuel in meeting future world energy needs and in achieving the targeted global reduction in the CO₂ emissions.

Two forms of energy, namely, electricity and hydrogen are predicted to dominate world energy system in the long term for the following reasons.

1. Electricity and hydrogen can be derived from renewable and/or inexhaustible energy sources, namely, nuclear, wind, biomass, solar, etc.
2. If produced from the above-mentioned sources, production processes are relatively environmentally benign, as are the combustion products produced (water and low- quality heat).
3. Electricity and hydrogen are interconvertible using electrolysis or fuel cells.
4. This energy system is very flexible because of variety of sources, diversity of production methods, options for storage and transportation, and spectrum of end-uses possible using this energy system.

In addition, hydrogen has very high energy release per unit mass, which is particularly advantageous in aviation applications. With proper management, it should not be any more difficult to use hydrogen than conventional fossil fuels.

Several techniques are used in the production of hydrogen, namely, steam reforming of fossil fuels, high temperature electrolysis of steam and thermochemical water-splitting. All the above-mentioned techniques for hydrogen production require process heat and/or steam at temperatures ranging from 700° to 900°C. Of all existing nonfossil fuel energy sources, only the MHR system can provide process heat at the required high temperatures.

Interfacing of the MHR heat source with the hydrogen production process equipment needs further development. Previous studies on a process heat High Temperature Gas-cooled Reactor (HTGR) system have shown that an indirect cycle concept of the MHR system through a secondary heat transport loop using an Intermediate Heat Exchanger (IHX) may be used to reduce potential radioactive contamination of the process equipment.

5.1 Hydrogen Production Processes

There are several techniques used in the production of hydrogen, namely, steam reforming of fossil fuels, high temperature electrolysis of steam and thermochemical water splitting. All the above-mentioned techniques for hydrogen production require process heat and steam at temperatures ranging from 700° to 900°C. Of all existing nonfossil fuel energy sources, only the MHR system can provide process heat at the required high temperatures. General Atomics has performed several studies of the hydrogen production techniques under the sponsorship of Gas Research Institute. They include hydrogen production from fossil fuel sources and thermochemical water splitting. Currently, a major effort is underway in Japan to demonstrate hydrogen production techniques using the high temperature process heat from a 30 MW(t) high temperature gas-cooled reactor (HTTR). Similar studies of hydrogen production using high temperature AVR reactor have been proposed in Germany.

A brief description of each of the above mentioned hydrogen production processes, and how the MHR system can be employed as a high temperature heat source in each of these processes is given below.

5.2 Steam Reforming of Methane

Currently, the steam reforming of methane is the most economically viable commercial hydrogen production technique. In this process [Figure 22(a)], methane in the form of natural gas or methane obtained using coal hydrogasification reacts with high temperature steam to form synthesis gas ($\text{CO} + \text{H}_2$). This reaction is endothermic and is optimized at a temperature of 800°C and a pressure of 175 psi. The process heat and the high temperature steam required by this reaction can be supplied by the MHR. Consequent water gas shift reaction results in maximizing the hydrogen yield.

Figure 22(b) shows a schematic of the MHR process configuration to produce hydrogen. Thermal efficiency as high as 60% to 70% can be realized using this process. It is estimated that a single 600 MW(t) unit can produce 575,000 lbm/day of hydrogen, which is equivalent to 5400 bbl/day of oil.

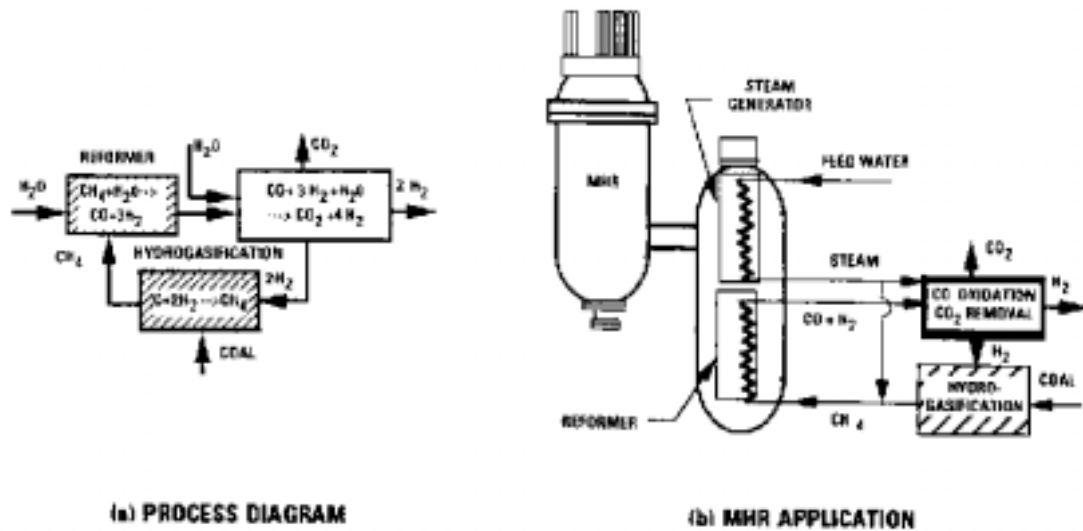

Fig. 22. Hydrogen Production by Steam Reforming of Methane

5.3 Water Electrolysis

Production of hydrogen from water using electrolysis [Figure 23(a)] on an industrial scale can be achieved at an efficiency of 50% to 60%. To improve this efficiency, methods such as high temperature electrolysis of steam or a solid electrolyte method are under development which are expected to yield efficiencies as high as 90%. If such a method can be implemented on an industrial scale, it will be economical to use surplus electricity to decompose water during off -peak periods of operation and utilize this hydrogen in a fuel cell when more electricity is required.

The MHR system in electricity generation mode can provide the required power input for water electrolysis [Figure 23(b)]. For high temperature electrolysis of steam (temperatures of 800° to 900°C), the MHR can provide both the electrical power as well as the high temperature steam.

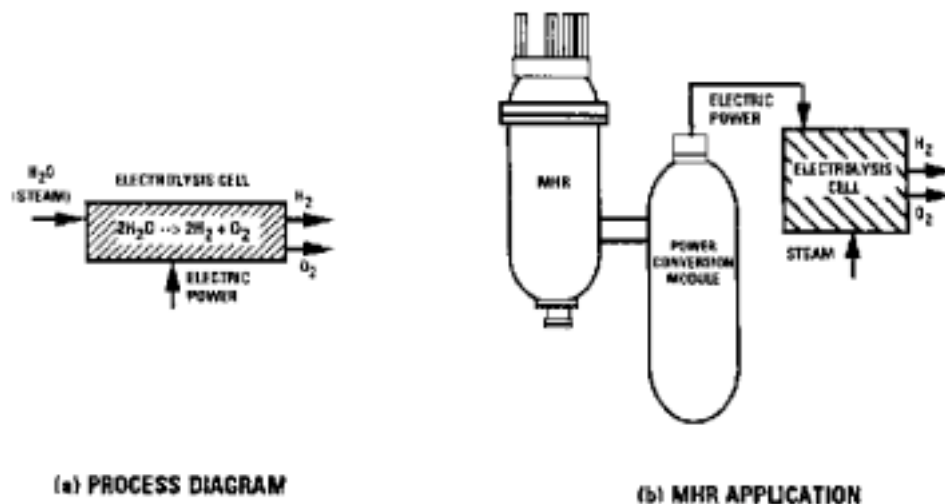

Fig. 23. Hydrogen Production Using Water Electrolysis

5.4 Thermochemical Water Splitting

Hydrogen production by thermochemical water splitting (Refs. 11, 12) involves high temperature (850°C) process chemical reactions in an iodine-sulfur cycle (IS cycle) which originally was developed by General Atomics in 1979. The classical Buunsen reaction involves [Figures 24(a) and 24(b)] the dissociation of sulfuric acid at a temperature of 850°C and the dissociation of hydriodic acid at a temperature of 500°C. In addition, acid separation requires water at a temperature of 200°C. Hydrogen is a product of the hydriodic acid (HI) decomposition. Both the sulfuric acid and the hydriodic acid are recycled. An operating process efficiency of 40% to 50% can be achieved using this chemical conversion process. Further development is required to establish this process on an industrial scale by optimizing the hydrogen production efficiency and to select required noncorrosive high temperature materials for thermochemical process.

Water electrolysis and chemical conversion of water using thermochemical water splitting processes are the preferred hydrogen processes, as they do not produce CO₂ emissions. An aggressive, results-oriented, multiyear initiative should be pursued to establish the commercial viability of these hydrogen production processes and to explore the technical requirements for industrial application of hydrogen in the early 21st century.

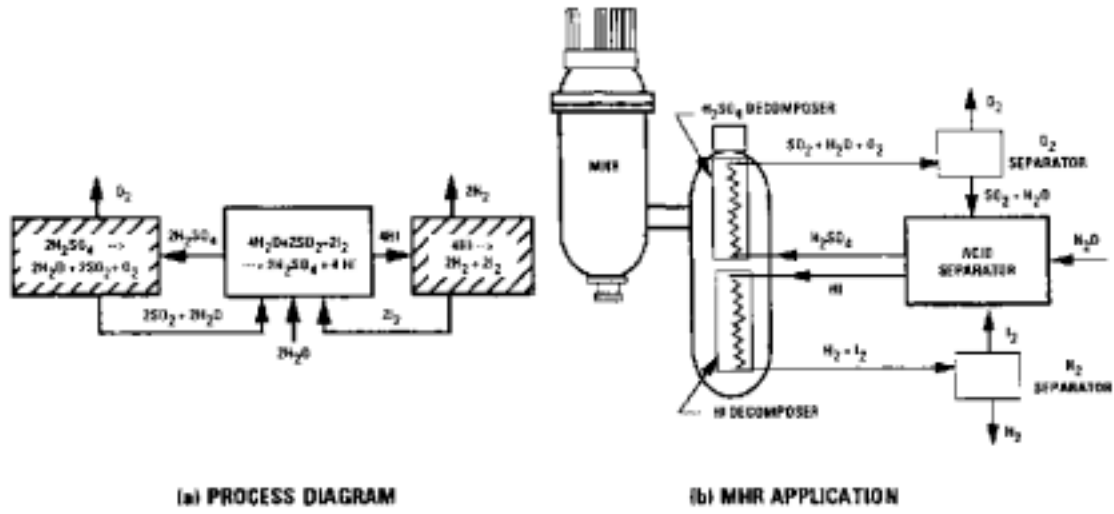

Fig. 24. Hydrogen Production Using Thermochemical Water Splitting

6. CONCLUSIONS

In the 21st century the forecast indicates significant increases in use of electrical and non-electrical energy by both developed and developing nations. All forms of energy including nuclear are required to meet this demand. Modular Helium Reactor is a unique source of nuclear energy that has large number of applications as summarized in Figure 25.

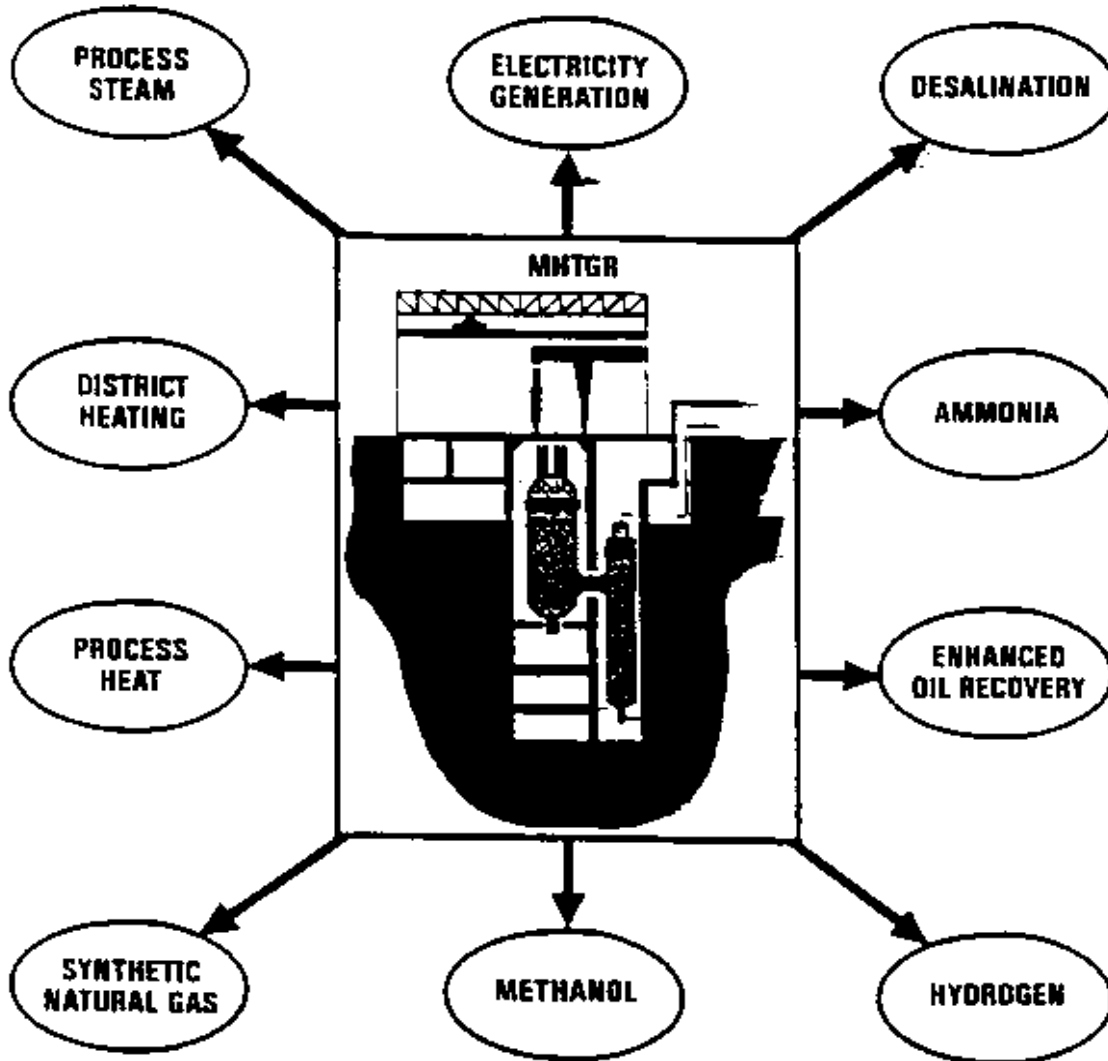

Fig. 25. Various Non-Electrical Applications of MHR Heat Source

7. REFERENCES

1. "Conceptual Design Summary Report, Modular HTGR Plant," DOE-HTGR-87-092, September 1987.
2. Rao, R., and A. T. McMMain, Jr., "1170-MW(t) HTGR-PS/C Plant Application Study Report: Heavy Oil Recovery Application," General Atomic Report GA-A16093.
3. Rao, R., and A. T. McMMain, Jr., "1170-MW(t) HTGR-PS/C Plant Application Study Report: Tar Sands Oil Recovery Application," General Atomic Report GA-A16083.
4. Rao, R., D. D. Peterman, and A. T. McMMain, Jr., "1170-MW(t) HTGR-PS/C Plant Application Study Report: SRC-II Process Application," General Atomic Report GA- A16108.
5. Rao, R., J. M. Neill, and A. T. McMMain, Jr., "1170-MW(t) HTGR-PS/C Plant Application Study Report: H-Coal Liquefaction Process Application," General Atomic Report GA- A16091.
6. Rao, R., D. D. Peterman, and A. T. McMMain, Jr., "1170-MW(t) *HTGR-PS/C* Plant Application Study Report: Exxon Catalytic Coal Gasification Process Application," General Atomic Report GA-A16113.
7. Stanley, J. D., and A. T. McMMain, Jr., "1170-MW(t) *HTGR-PS/C* Plant Application Study Report: Steel Mill Application," General Atomic Report GA-A16074.
8. Stanley, J. D., and A. T. McMMain, Jr., "1170-MW(t) *HTGR-PS/C* Plant Application Study Report: Alumina Plant Application," General Atomic Report GA-A16100.
9. Schleicher, R. W., and A. J. Kennedy, "Potential Application of High Temperature Helium," 2nd JAERI Symposium on HTGR Technologies, October 21-23, 1992.
10. Schleicher, R. W., D. E. Engler and M. P. LaBar, "Methanol from Coal Without CQ2 Production via the Modular High Temperature Gas-Cooled Reactor," Proceedings of 54th American Power Conference, April 1992.
11. Russell, J. L., Jr., *et al.*, "Development of Thermochemical Water Splitting for Hydrogen production at General Atomic Company," General Atomic Report GA-A14050, September 30, 1976.
12. Schuster, I. R., *et al.*, "Development of a Sulfur-Iodine Thermochemical Water-Splitting Cycle for Hydrogen Production," General Atomic Report GA-A14307, May 1977. [Paper presented at the 12th Intersociety Energy Conversion Engineering Conference (IECEC), Washington, D.C., August 28 through September 2, 1977].

